



Designation: D6775 – 02 (Reapproved 2007)

Standard Test Method for Breaking Strength and Elongation of Textile Webbing, Tape and Braided Material¹

This standard is issued under the fixed designation D6775; the number immediately following the designation indicates the year of original adoption or, in the case of revision, the year of last revision. A number in parentheses indicates the year of last reapproval. A superscript epsilon (ϵ) indicates an editorial change since the last revision or reapproval.

1. Scope

1.1 This test method covers the determination of the breaking strength and elongation of textile webbing, tape and braided materials using a split-drum type specimen clamp.

1.2 This test method is limited to materials with a maximum width of 90 mm (3.5 in.) and a maximum breaking strength of no more than 89000N (20000 lb).

1.3 The values stated in either SI units or U.S. Customary units are to be regarded separately as standard. Within the text, the U.S. Customary units are given in parentheses. The values stated in each system are not exact equivalents; therefore, each system shall be used independently of the other.

1.4 *This standard does not purport to address all of the safety concerns, if any, associated with its use. It is the responsibility of the user of this standard to establish appropriate safety and health practices and determine the applicability of regulatory limitations prior to use.*

2. Referenced Documents

2.1 *ASTM Standards:*²

[D76](#) Specification for Tensile Testing Machines for Textiles

[D123](#) Terminology Relating to Textiles

[D1776](#) Practice for Conditioning and Testing Textiles

[D4848](#) Terminology Related to Force, Deformation and Related Properties of Textiles

[D4850](#) Terminology Relating to Fabrics and Fabric Test Methods

3. Terminology

3.1 For definitions of terms related to force and deformation used in this test method, refer to Terminology [D4848](#). For definitions of other terms related to textiles used in this standard, refer to Terminology [D123](#), and [D4850](#).

¹ This test method is under the jurisdiction of ASTM Committee [D13](#) on Textiles and is the direct responsibility of Subcommittee [D13.60](#) on Fabric Test Methods, Specific.

Current edition approved Jan. 1, 2007. Published January 2007. Originally approved in 2002. Last previous edition approved in 2002 as D6775 – 02^{e1}. DOI: 10.1520/D6775-02R07.

² For referenced ASTM standards, visit the ASTM website, www.astm.org, or contact ASTM Customer Service at service@astm.org. For *Annual Book of ASTM Standards* volume information, refer to the standard's Document Summary page on the ASTM website.

4. Summary of Test Method

4.1 A specimen is clamped in a tensile testing machine and extended to rupture. The breaking force is determined from a force-elongation curve or with an interfaced computer. Elongation is determined by calculating the difference between bench marks before the application of a force and at a specified force.

5. Significance and Use

5.1 This test method can be used for acceptance testing of commercial shipments but comparisons should be made with caution because estimates of between-laboratory precision are incomplete.

5.1.1 If there are differences of practical significance between reported test results for two laboratories (or more), comparative tests should be performed to determine if there is a statistical bias between them, using competent statistical assistance. As a minimum, use samples for such comparative tests that are as homogeneous as possible, drawn from the same lot of material as the samples that resulted in disparate results during initial testing, and randomly assigned in equal numbers to each laboratory. The test results from the laboratories involved should be compared using a statistical test for unpaired data, at a probability level chosen prior to the testing series. If bias is found, either its cause must be found and corrected, or future test results for that material must be adjusted in consideration of the known bias.

5.2 Elongation is an indication of the ability of a fiber to absorb energy. The elongation of textile materials must be great enough to withstand strains experienced in processing and end use, and to absorb the energies of applied forces repeatedly.

6. Apparatus³

6.1 *Tensile Testing Machine*, CRE-type, conforming to Specification [D76](#) with respect to force indication, working range, capacity and verification of recorded elongation, and designed for operation at a pulling speed of 75 ± 25 mm/min (3 ± 1 in./min).

6.2 *Clamping Assembly*, consisting of an upper and lower clamp, each a split-drum type, as shown in [Fig. 1](#) and [Fig. 2](#).

³ Apparatus and clamps are commercially available.

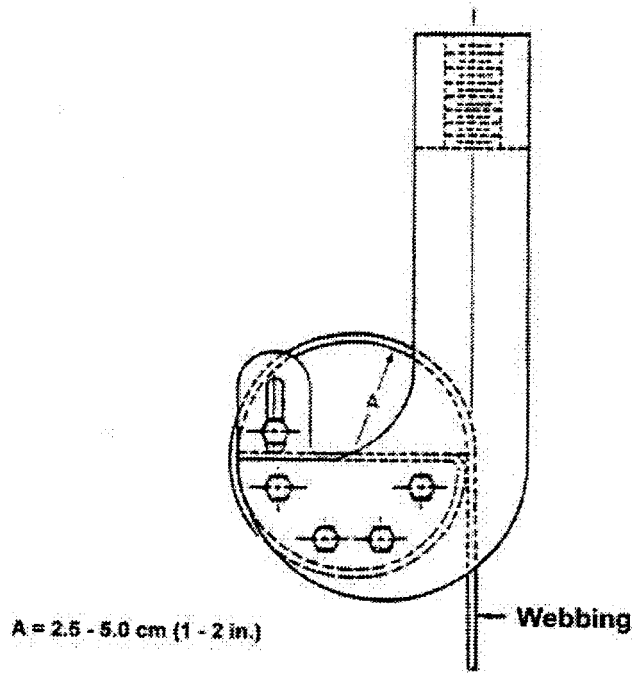

TEST JAWS FOR HIGH STRENGTH TEXTILES

FIG. 1 Side View of Clamping Assembly

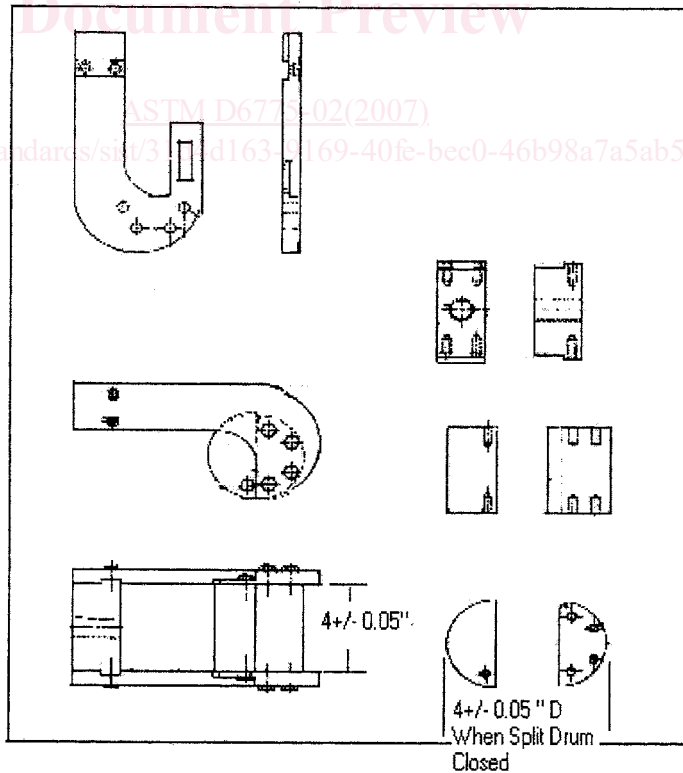

FIG. 2 Example of Clamping Assembly