

INTERNATIONAL STANDARD

ISO
815

Second edition
1991-11-01

Rubber, vulcanized or thermoplastic — Determination of compression set at ambient, elevated or low temperatures

iTeh STANDARD PREVIEW

(standards.iteh.ai)
*Caoutchouc vulcanisé ou thermoplastique — Détermination de la
déformation rémanente après compression aux températures ambiantes,
élevées ou basses*

ISO 815:1991

<https://standards.iteh.ai/catalog/standards/sist/64ecab13-0f0e-437d-9d3d-388fdccd206/iso-815-1991>



Reference number
ISO 815:1991(E)

Foreword

ISO (the International Organization for Standardization) is a worldwide federation of national standards bodies (ISO member bodies). The work of preparing International Standards is normally carried out through ISO technical committees. Each member body interested in a subject for which a technical committee has been established has the right to be represented on that committee. International organizations, governmental and non-governmental, in liaison with ISO, also take part in the work. ISO collaborates closely with the International Electrotechnical Commission (IEC) on all matters of electrotechnical standardization.

Draft International Standards adopted by the technical committees are circulated to the member bodies for voting. Publication as an International Standard requires approval by at least 75 % of the member bodies casting a vote.

International Standard ISO 815 was prepared by Technical Committee ISO/TC 45, *Rubber and rubber products*, Sub-Committee SC 2, *Physical and degradation tests*.

This second edition cancels and replaces the first edition (ISO 815:1972) and the first edition of ISO 1653 (ISO 1653:1975), of which it constitutes a technical revision.

Annexes A and B of this International Standard are for information only.

© ISO 1991

All rights reserved. No part of this publication may be reproduced or utilized in any form or by any means, electronic or mechanical, including photocopying and microfilm, without permission in writing from the publisher.

International Organization for Standardization
Case Postale 56 • CH-1211 Genève 20 • Switzerland

Printed in Switzerland

Rubber, vulcanized or thermoplastic — Determination of compression set at ambient, elevated or low temperatures

1 Scope

This International Standard specifies methods for the determination of compression set characteristics of vulcanized and thermoplastic rubbers at ambient, elevated or low temperatures.

The methods are intended to measure the ability of rubbers of hardness within the range 10 IRHD to 95 IRHD to retain their elastic properties at specified temperatures after prolonged compression at constant strain (where possible 25 %) under one of the alternative sets of conditions described. For rubber of hardness greater than 80 IRHD, a lower compression strain is used: 15 % for a nominal hardness from 80 IRHD to 89 IRHD and 10 % for a nominal hardness from 90 IRHD to 95 IRHD.

NOTES

1 When rubber is held under compression, physical or chemical changes can occur that prevent the rubber returning to its original dimensions after release of the deforming force. The result is a set the magnitude of which depends on the time and temperature of compression as well as on the time and temperature of recovery. At elevated temperatures, chemical changes become increasingly more important and lead to a permanent set which can be measured by allowing test pieces to recover at standard temperature. At low temperatures, changes resulting from the effects of glass hardening or crystallization become predominant, and since these effects are reversed by raising the temperature it is necessary for all measurements to be undertaken at the test temperature (see ISO 6471).

2 Guidance for using the precision results is given in informative annex A, and results for compression set at -25°C and 100°C without lubricant in informative annex B.

2 Normative references

The following standards contain provisions which, through reference in this text, constitute provisions of this International Standard. At the time of publication, the editions indicated were valid. All stan-

dards are subject to revision, and parties to agreements based on this International Standard are encouraged to investigate the possibility of applying the most recent editions of the standards indicated below. Members of IEC and ISO maintain registers of currently valid International Standards.

ISO 468:1982, *Surface roughness — Parameters, their values and general rules for specifying requirements.*

ISO 471:1983, *Rubber — Standard temperatures, humidities and times for the conditioning and testing of test pieces.*

ISO 1826:1981, *Rubber, vulcanized — Time-interval between vulcanization and testing — Specification.*

ISO 3383:1985, *Rubber — General directions for achieving elevated or subnormal temperatures for test purposes.*

ISO 4648:1991, *Rubber, vulcanized or thermoplastic — Determination of dimensions of test pieces and products for test purposes.*

ISO 4661-1:1986, *Rubber, vulcanized — Preparation of samples and test pieces — Part 1: Physical tests.*

ISO 6471:1983, *Rubber, vulcanized — Determination of crystallization effects under compression.*

ISO/TR 9272:1986, *Rubber and rubber products — Determination of precision for test method standards.*

3 Principle

3.1 Ambient and elevated temperatures

A test piece of known thickness is compressed at standard temperature to a defined strain, which is then maintained constant for a specified time at a fixed standard or elevated temperature. The strain

is released and, after the test piece has been allowed to recover at standard temperature for a specified time, the thickness of the test piece is again measured.

3.2 Low temperatures

A test piece of known thickness is compressed at standard temperature to a defined strain, which is then maintained constant for a specified time at a fixed low temperature. The strain is released and the test piece allowed to recover at this temperature. The thickness is measured at intervals after the release of the strain so that an assessment of compression set characteristics is obtained from a plot of recovery against time at the low temperature.

4 Apparatus

4.1 Compression apparatus, consisting of compression plates, steel spacers and clamping device.

4.1.1 Compression plates, comprising a pair of parallel, flat, highly polished chromium-plate steel or highly polished stainless-steel plates, between the faces of which the test piece is compressed.

The finish of the surface of the compression plates shall be not worse than $0,4 \mu\text{m } R_a$ from the mean line of the profile (see ISO 468). The plates shall

- be sufficiently rigid to ensure that, with a test piece under load, no compression plate shall bend by more than 0,01 mm;
- be of sufficient size to ensure that the whole of the test piece, when compressed between the plates, remains within the area of the plates.

Steel plates with a diameter of approximately 115 mm and with a thickness of 6,5 mm and 12,5 mm, respectively, are suggested. A typical apparatus is shown in figure 1.

4.1.2 Temperature measurement device.

For low-temperature tests, the plates shall incorporate means of measuring their temperature directly with an accuracy of $\pm 0,5 \text{ }^\circ\text{C}$.

4.1.3 Mild-steel spacer(s), to provide the required compression. The spacer(s) shall be of such size and shape that contact with the compressed test piece is avoided.

The height of the spacer(s) shall be as follows: where more than one spacer is used in any one test,

the heights shall match to within $\pm 0,01 \text{ mm}$ of the mean.

Spacer dimensions	Test piece type
9,4 mm max.	A
9,3 mm min.	
4,8 mm max.	B
4,7 mm min.	

When crystallization studies are to be made, it is necessary to control the compression strain as accurately as possible, and spacers of different heights are required. The height of the spacers shall be chosen so that the compression of the test piece is $(25 \pm 1) \%$ of the measured thickness of the test piece.

A compression strain of 15 % shall be used for hardnesses between 80 IRHD and 89 IRHD. The height of the spacer(s) shall be as follows:

Spacer dimensions	Test piece type
10,7 mm max.	A
10,6 mm min.	
5,4 mm max.	B
5,3 mm min.	

A compression strain of 10 % shall be used for hardnesses above 90 IRHD. The height of the spacer(s) shall be as follows:

Spacer dimensions	Test piece type
11,30 mm max.	A
11,25 mm min.	
5,70 mm max.	B
5,65 mm min.	

NOTE 3 For crystallization studies, in order to achieve the accuracy of compression needed to meet the permitted tolerances on test piece height, three sets of spacers for type A and four sets of spacers for type B are required. For instance, spacers of heights 9,12 mm, 9,38 mm and 9,62 mm for type A and spacers of heights 4,56 mm, 4,67 mm, 4,78 mm and 4,89 mm for type B, all to a tolerance of $\pm 0,005 \text{ mm}$, would cover the range adequately.

Where a range of spacers is not available, the use of slip gauges is recommended to obtain the correct compressed height. Care shall be taken that, with the test piece in its compressed state, the compression plates are parallel.

Dimensions in millimetres

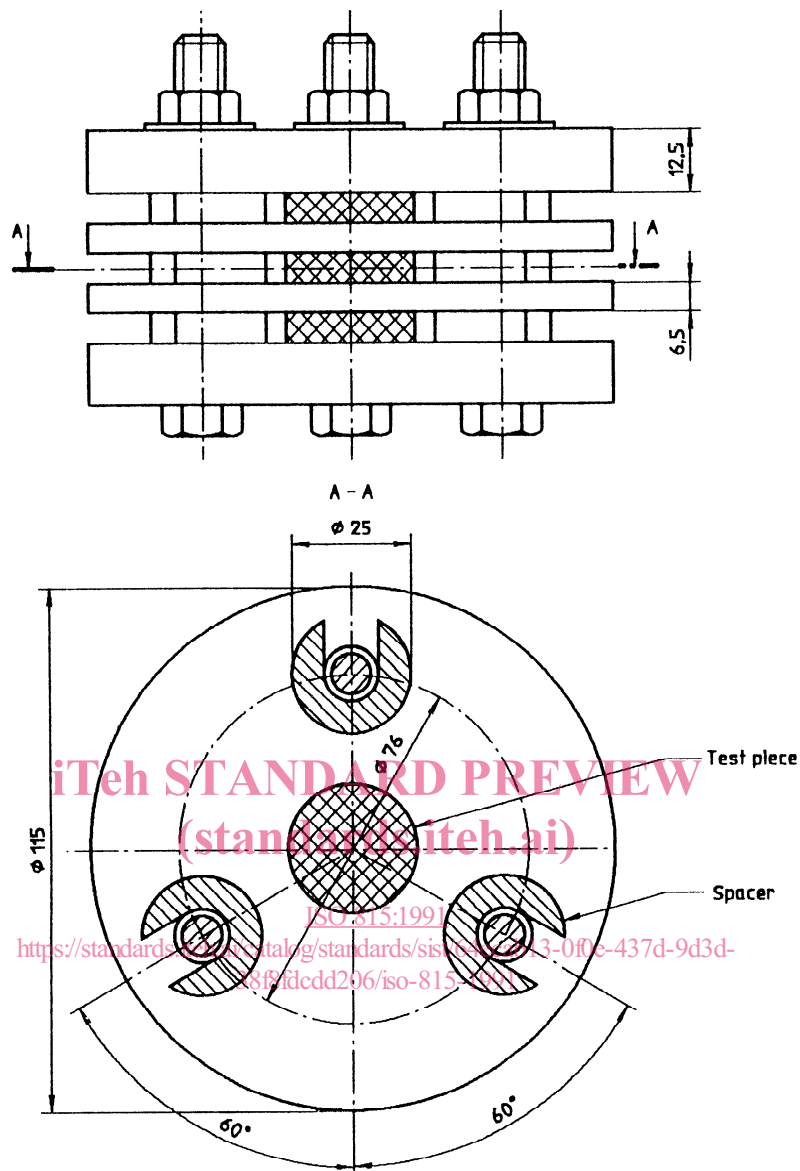

Figure 1 — Typical apparatus for the determination of compression set using type A test pieces

4.1.4 Clamping device.

For testing at standard or elevated temperatures, a simple screw device is adequate. For testing at low temperatures, a quick-release device is required. This may be either mechanical or pneumatic.

4.2 Oven or low-temperature cabinet, complying with the requirements specified in ISO 3383, and capable of maintaining the compression apparatus and test pieces at the test temperature within the tolerance specified in 6.2.

The low-temperature cabinet may be mechanically refrigerated or may be cooled directly by dry ice or liquid nitrogen. The test temperature shall be

measured directly in the plates of the compression apparatus with an accuracy of $\pm 0,5$ °C.

The cabinet for low-temperature testing shall be equipped so that it is possible to release the test pieces and carry out subsequent measurements without direct contact, e.g. by use of hand-holes and gloves or a remote-handling device. The cabinet shall be capable of maintaining its temperature within the permissible variation while these operations are being carried out.

The time to reach a steady-state temperature depends on the type of oven or cabinet and the heat content of all the compression apparatus. To obtain comparable results in the case of an elevated test temperature and a 24 h duration of test, it is necessary to reach the steady-state temperature

within the specified tolerances in the interior of the test pieces at least after 3 h.

4.3 Pair of tongs, for handling the test pieces.

4.4 Micrometer dial gauge (to measure the thickness of the test piece), having a flat circular foot of 4 mm to 10 mm in diameter and a flat solid base plate (see ISO 4648:1991, method A) exerting a pressure of 22 kPa \pm 5 kPa. It shall be suitable for use at the required test temperature and shall be calibrated for measurements at that temperature. For comparative purposes, the same dimensions of the circular foot shall be used.

4.5 Timing device, with a precision of $\pm 0,2$ s or ± 1 %, whichever is the less precise.

5 Test pieces

5.1 Dimensions

The test pieces shall be one of two sizes, designated type A and type B.

A type A test piece shall be a cylindrical disc of diameter 29 mm \pm 0,5 mm and thickness 12,5 mm \pm 0,5 mm.

A type B test piece shall be a cylindrical disc of diameter 13 mm \pm 0,5 mm and thickness 6,3 mm \pm 0,3 mm.

These two types do not necessarily give the same values for compression set, and comparison of results obtained using test pieces of different sizes shall be avoided.

Type A test pieces are preferred for testing rubbers having low compression set, because of the greater accuracy attainable using these larger test pieces. Type B test pieces are preferred when it is required to cut test pieces from products. In this case, the test pieces shall be taken as near to the centre of the product as possible, unless otherwise specified.

5.2 Preparation

The test pieces shall be prepared by moulding each disc, whenever possible. Preparation by cutting each disc or by laminating not more than 3 discs is permitted.

Cutting shall be performed in accordance with ISO 4661-1.

Laminated test pieces shall conform with the dimensions specified in 5.1 and shall be prepared by laminating discs or rubber cut from sheets without adhesives. Discs may be compressed by a few percent for 1 min, so that they stick together. The number of discs laminated to produce a test piece shall

not exceed three. The total thickness shall then be measured.

Test pieces prepared by the different methods described above may give different results and comparison of values shall be avoided.

NOTE 4 Attention is drawn to the marked effects of the degree of cross-linking on compression set values. It may be necessary to adjust the cure of moulded test pieces to be representative of different thicknesses of sheets or mouldings.

When cupping is a problem, the test piece shape can be improved by cutting it in two stages: first cut an oversize test piece and then trim it to the exact dimensions with a second cutter.

The use of test pieces prepared by laminating several discs for control of finished products shall be agreed between interested parties.

5.3 Measurement of thickness

The thickness shall be measured at the central portion of the test piece to the nearest 0,01 mm using the micrometer dial gauge (4.4).

5.4 Number

Three individual test pieces shall be tested. For low-temperature tests, each test piece shall be tested in a separate clamping device (4.1.4).

5.5 Time-interval between vulcanization and testing

For all test purposes, the minimum time between vulcanization and testing shall be 16 h.

For non-product tests, the maximum time between vulcanization and testing shall be 4 weeks, and for evaluations intended to be comparable, the tests, as far as possible, shall be carried out after the same time-interval.

For product tests, whenever possible, the time between vulcanization and testing shall not exceed 3 months. In other cases, tests shall be made within 2 months of the date of receipt of the product by the purchaser (see ISO 1826).

5.6 Conditioning

Samples and test pieces shall be protected from light and heat as much as possible during the interval between vulcanization and testing.

Prepared test pieces shall be conditioned immediately before testing for a minimum period of 3 h at one of the standard temperatures specified in ISO 471. The same temperature shall be used

throughout any one test or series of tests intended to be comparable.

In the case of crystallization studies, test pieces shall be decrystallized immediately before testing by heating them in an oven (4.2) at 70 °C for 45 min. They shall then be conditioned at standard temperature.

6 Test conditions

6.1 Duration of test

The exposure time shall be (24 \pm 2) h, (72 \pm 2) h, (168 \pm 2) h or multiples of 168 h, measured from the moment of placing the compression apparatus in the oven or low-temperature cabinet (4.2).

In the case of low temperatures, the preferred times are (24 \pm 2) h or (72 \pm 2) h.

Longer times may be used when studying crystallization or plasticizer migration at specified test temperatures.

6.2 Temperature of test

The temperatures of test shall be one of the standard temperatures 23 °C \pm 2 °C or 27 °C \pm 2 °C (see ISO 471) for tests at ambient temperature, and one of the following temperatures for elevated-temperature or low-temperature tests:

Elevated temperatures °C	Low temperatures °C
40 \pm 1	0 \pm 1
55 \pm 1	-10 \pm 1
70 \pm 1	-25 \pm 1
85 \pm 1	-40 \pm 1
100 \pm 1	-55 \pm 1
125 \pm 2	-70 \pm 1
150 \pm 2	-80 \pm 1
175 \pm 2	-100 \pm 2
200 \pm 2	
225 \pm 2	
250 \pm 2	

Special care shall be taken in interpreting results obtained at elevated temperatures. As oven temperatures are increased, the results become increasingly dependent upon the thermal stability of the vulcanizate. At still higher temperatures, surface oxidation of the test piece makes a significant contribution to the observed compression set. There is no simple correlation between the compression set

observed at elevated temperatures and that observed at room temperature.

7 Procedure

7.1 Preparation of compression apparatus

With the compression apparatus (4.1) at standard temperature, carefully clean the operating surfaces. Apply a thin coating of lubricant to the faces of the compression plates (4.1.1) that will come into contact with the test pieces. The lubricant used shall have no substantial action on the rubber during the test and it shall be described in the test report (see clause 10).

NOTE 5 For most purposes, a silicone or fluorosilicone liquid having a kinematic viscosity of 0,01 m²/s at standard temperature is a suitable lubricant.

If for any reason a lubricant is not used, this shall be mentioned in the test report or the product specification.

7.2 Thickness measurement

Measure the thickness in the centre of each test piece to the nearest 0,01 mm.

7.3 Applying the compression

Place the test pieces between the pairs of plates together with the spacer(s) (4.1.3), avoiding contact between test pieces and bolts or spacer(s). Tighten the clamping device (4.1.4) so that the plates are drawn together uniformly until they are in contact with the spacer(s). The applied compression shall be approximately 25 % of the original thickness of the test piece. For higher hardnesses, the applied compression shall be approximately 15 % or 10 % (see 4.1.3).

7.4 Starting the test

Without delay, introduce the compression apparatus containing the test pieces into the central part of the oven or low-temperature cabinet (4.2) operating at the test temperature (see 6.2).

7.5 Terminating the test in the case of elevated temperatures

7.5.1 After the required test duration (see 6.1), remove the compression apparatus from the oven. Immediately loosen the bolts and transfer the test pieces quickly to a wooden bench. Leave them to recover at standard temperature for 30 min \pm 3 min, and then measure their thickness.

7.5.2 An alternative method of cooling may be used, in which the whole compression set assembly is cooled to standard temperature within 30 min to 120 min, the test pieces are released, and after a further 30 min \pm 3 min the thickness is measured. If this cooling method is used, it shall be clearly stated in the test report.

7.6 Terminating the test in the case of low temperatures

7.6.1 After the required test duration, release the clamping device as quickly as possible and simultaneously start the timing device (4.5).

7.6.2 Inside the cabinet, measure the thickness of the central portion of the test piece, to the nearest 0,01 mm, at time intervals beginning as quickly as possible after release of the clamping device and ending after 2 h, which makes it possible to plot thickness against the logarithm of time (10 s, 30 s, 1 min, 3 min, 10 min, 30 min and 2 h are suggested). Test pieces shall always be handled with the tongs (4.3). After 2 h, remove the test piece from the cabinet.

7.7 Internal examination

Cut the test pieces into two pieces along a diameter; if any internal defects, such as gas bubbles, are found, discard the test result.

8 Expression of results

8.1 The compression set C , expressed as a percentage of the initial compression, is given by the formula

$$\frac{h_0 - h_1}{h_0 - h_s} \times 100$$

where

- h_0 is the initial thickness, in millimetres, of the test piece;
- h_1 is the thickness, in millimetres, of the test piece after recovery;
- h_s is the height, in millimetres, of the spacer.

Report the result to the nearest 1 %.

8.2 No individual test result shall vary from the numerical value of the median compression set by more than 2 % or by more than 1/10th of the mean, whichever is higher. If it does, three more test pieces shall be tested and the median value of all results shall be reported, together with the number of test pieces tested.

8.3 In the case of low-temperature testing, results shall be presented for each test piece by plotting on graph paper with semi-logarithmic scales, with the time on the logarithmic abscissa and the thickness on the linear ordinate. In the time range of the recovery process, an approximately straight line will result in most cases, which permits the calculation of the thickness value after any desired time of recovery by extrapolation (two orders of 10 of time) or by interpolation.

Normally, compression set values are calculated after recovery periods of 30 s and 30 min.

9 Precision

9.1 General

The precision calculations to express repeatability and reproducibility were performed in accordance with ISO/TR 9272. Consult this for precision concepts and nomenclature. Annex A gives guidance on the use of repeatability and reproducibility.

9.2 Precision details

9.2.1 An interlaboratory test programme (ITP) was organized in 1986 by the Laboratoire de Recherche et de Contrôle du Caoutchouc et des Plastiques (LRCCP). Three materials (vulcanized rubber compounds) were used: A = SBR, B = NBR, C = EPDM. Test pieces were distributed to all laboratories and tested at 100 °C and at -25 °C in accordance with this International Standard.

9.2.2 Two types of cylindrical test piece were used: type A had a diameter of 29 mm \pm 0,5 mm and a thickness of 12,5 mm \pm 0,5 mm; type B had a diameter of 13 mm \pm 0,5 mm and a thickness of 6,3 mm \pm 0,3 mm.

9.2.3 The test method calls for the use of a lubricant between the surfaces of the test pieces and the compression plates. To determine if the use of a lubricant influences the results, all testing was conducted with and without a lubricant.

9.2.4 Tests were conducted for (24 \pm 2) h at approximately 25 % compression, on three test pieces for each test condition. A median compression set value was used as a "test result" as specified in the method. For testing at 100 °C, the compression set was measured after 30 min \pm 3 min of recovery time at room temperature after removal from the apparatus.

9.2.5 For testing at -25 °C, the compression set was measured 30 s and 30 min after removal of the test piece from the apparatus, while the test piece was still at -25 °C.

9.2.6 A type 1 precision was measured in the ITP. The time period for repeatability and reproducibility is on a scale of days. A total of 19 laboratories participated in the 100 °C test and 12 laboratories participated in the – 25 °C test.

9.3 Precision results

9.3.1 The precision results for the lubricated test piece testing are given in table 1 for compression set at 100 °C and in table 2 for compression set at – 25 °C.

9.3.2 The precision results for non-lubricated testing are given in annex B.

9.3.3 The symbols r , (r), R , (R), as used in the tables of results, are defined as follows:

r = repeatability, in measurement units

(r) = repeatability, in percent (relative)

R = reproducibility, in measurement units

(R) = reproducibility, in percent (relative)

10 Test report

The test report shall include the following information:

a) sample details:

- 1) a full description of the sample and its origin,
- 2) compound and cure details, where appropriate,
- 3) the method of preparation of test pieces from samples, for example whether moulded or cut;

b) test method:

- 1) a full reference to the test method used, i.e. the number of this International Standard,
- 2) the type of test piece used, i.e. A or B and whether or not it was laminated,
- 3) the nature of the lubricant,
- 4) whether the test pieces were tested separately or as a set;

c) test details:

- 1) the laboratory temperature,
- 2) the temperature and time of conditioning and of recovery,
- 3) the duration and temperature of test,
- 4) the diameter of the circular micrometer foot,
- 5) details of any procedures not specified in this International Standard;

d) test results:

- 1) the number of test pieces used,
- 2) the initial thickness h_0 of the test pieces, if required,
- 3) the thickness h_1 of the test pieces after recovery, if required,
- 4) the median value of the compression set and, if required, the individual test results,
- 5) in the case of low-temperature tests, a graphical presentation;

e) the date of the test.

ITeH STANDARD PREVIEW
(standards.iteh.ai)

for ISO 815:1991
<https://standards.iteh.ai/catalog/standards/sist/64ecab15-010c-497d-9d3d-388fdcd206/iso-815-1991>