



SLOVENSKI STANDARD
SIST EN 848-1:2000/A1:2000

01-december-2000

**Safety of woodworking machines - One side moulding machines with rotating tool
- Part 1: Single spindle vertical moulding machines**

Safety of woodworking machines - One side moulding machines with rotating tool - Part
1: Single spindle vertical moulding machines

Sicherheit von Holzbearbeitungsmaschinen - Fräsmaschinen für einseitige Bearbeitung
mit drehendem Werkzeug - Teil 1: Einspindelige senkrechte Tischfräsmaschinen

Sécurité des machines pour le travail du bois - Machines à fraiser sur une face, a outil
rotatif - Partie 1: Toupies monobroche a arbre vertical

<https://standards.iteh.ai/catalog/standards/sist/1ac6335c-caea-4dba-8263-fda7f7b88d9/sist-en-848-1-2000-a1-2000>

Ta slovenski standard je istoveten z: EN 848-1:1998/A1:2000

ICS:

79.120.10 Lesnoobdelovalni stroji Woodworking machines

SIST EN 848-1:2000/A1:2000 en

iTeh STANDARD PREVIEW
(standards.iteh.ai)

SIST EN 848-1:2000/A1:2000

<https://standards.iteh.ai/catalog/standards/sist/1ac6335c-caea-4dba-8263-fda7ff7b88d9/sist-en-848-1-2000-a1-2000>

English version

Safety of woodworking machines - One side moulding machines
with rotating tool - Part 1: Single spindle vertical moulding
machines

Sécurité des machines pour le travail du bois - Machines à
fraisier sur une face, à outil rotatif - Partie 1: Toupies
monobroche à arbre vertical

Sicherheit von Holzbearbeitungsmaschinen -
Fräsmaschinen für einseitige Bearbeitung mit drehendem
Werkzeug - Teil 1: Einspindelige senkrechte
Tischfräsmaschinen

This amendment A1 modifies the European Standard EN 848-1:1998; it was approved by CEN on 18 June 2000.

CEN members are bound to comply with the CEN/CENELEC Internal Regulations which stipulate the conditions for inclusion of this amendment into the relevant national standard without any alteration. Up-to-date lists and bibliographical references concerning such national standards may be obtained on application to the Central Secretariat or to any CEN member.

This amendment exists in three official versions (English, French, German). A version in any other language made by translation under the responsibility of a CEN member into its own language and notified to the Central Secretariat has the same status as the official versions.

CEN members are the national standards bodies of Austria, Belgium, Czech Republic, Denmark, Finland, France, Germany, Greece, Iceland, Ireland, Italy, Luxembourg, Netherlands, Norway, Portugal, Spain, Sweden, Switzerland and United Kingdom.

iTeh STANDARD PREVIEW
(standards.iteh.ai)

<https://standards.iteh.ai/catalog/standards/sist/1ac6333c-caea-4dba-8263-fda7ff7b88d9/sist-en-848-1-2000-a1-2000>



EUROPEAN COMMITTEE FOR STANDARDIZATION
COMITÉ EUROPÉEN DE NORMALISATION
EUROPÄISCHES KOMITEE FÜR NORMUNG

Central Secretariat: rue de Stassart, 36 B-1050 Brussels

Foreword

This Amendment EN 848:1998/A1:2000 to EN 848-1:1998 has been prepared by Technical Committee CEN/TC 142 " Woodworking machines - Safety ", the secretariat of which is held by BSI.

This Amendment to the European Standard EN 848-1:1998 shall be given the status of a national standard, either by publication of an identical text or by endorsement, at the latest by janvier 2001, and conflicting national standards shall be withdrawn at the latest by janvier 2001.

This Amendment to the European Standard EN 848-1:1998 has been prepared under a mandate given to CEN by the European Commission and the European Free Trade Association, and supports essential requirements of EU Directive(s).

According to the CEN/CENELEC Internal Regulations, the national standards organizations of the following countries are bound to implement this European Standard: Austria, Belgium, Czech Republic, Denmark, Finland, France, Germany, Greece, Iceland, Ireland, Italy, Luxembourg, Netherlands, Norway, Portugal, Spain, Sweden, Switzerland and the United Kingdom.

This amendment clarifies the requirements on safeguarding equipment for curved work which is located at the end of annex B "Rigidity tests for pressure pads, hand protector and guiding steady".

iTeh STANDARD PREVIEW (standards.iteh.ai)

SIST EN 848-1:2000/A1:2000

<https://standards.iteh.ai/catalog/standards/sist/1ac6335c-caea-4dba-8263-fda7ff7b88d9/sist-en-848-1-2000-a1-2000>

B.2.1 Adjustable guard

Replace this subclause by the following :

"Figure B.6 shows the point of application and the direction of forces A, B, D and F to be applied to the adjustable guard under test together and the position of the measuring point.

Force F is applied to the adjustable guard towards the spindle axis.

The test shall be performed with the safeguarding equipment in a position where the displacement is the greatest."

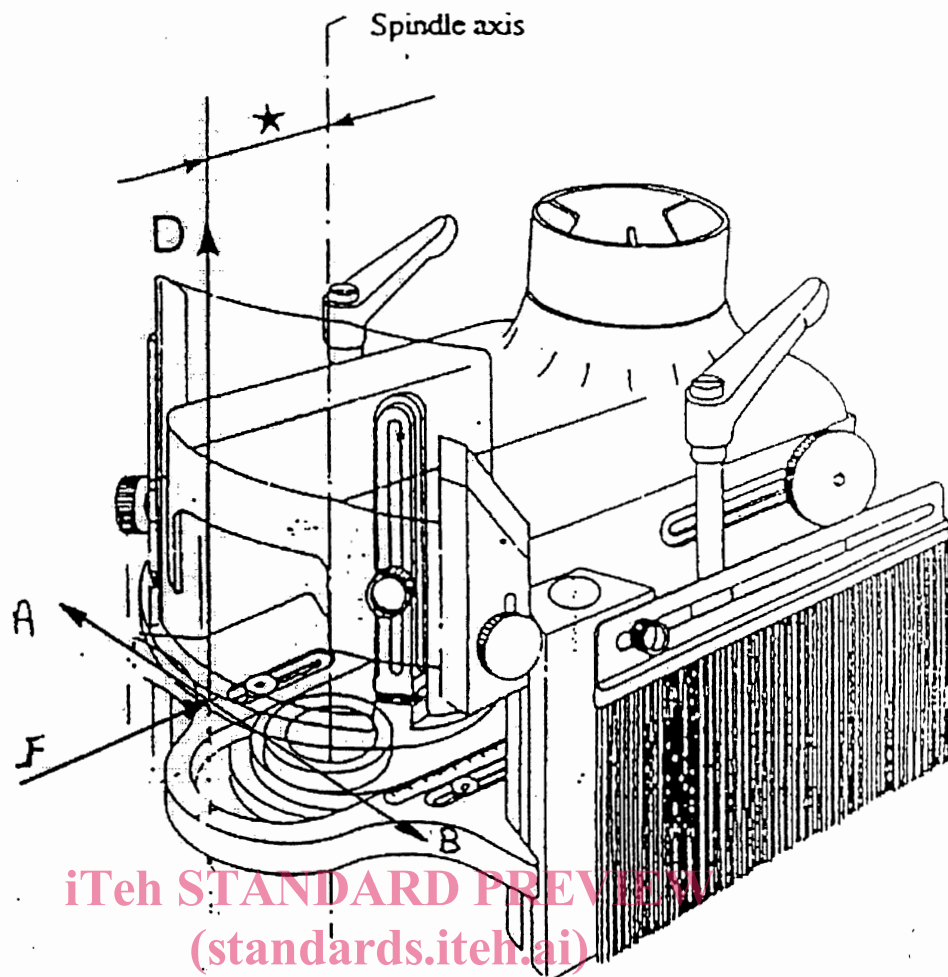

iTeh STANDARD PREVIEW
(standards.iteh.ai)

SIST EN 848-1:2000/A1:2000

Figure B.6 : Definition of the adjustable guard deflection measuring points and directions of application of test forces

Table B.3 : Guiding steady deflection requirements

Direction of application	Force (N)	Maximum displacement (including clearance) mm
A	100	2
B	100	2
C	100	7
F	100	0,5

B.2.4 Test

Replace this subclause by the following :

"When forces are applied as described in B.2.1 and B.2.2, displacements exceeding the values given in tables B.2 and B.3 shall not occur whatever the spindle diameter.

There shall be no permanent distorsion of the adjustable guard or guiding steady following the test. The adjustable guard and guiding steady shall not rotate around any horizontal axis."

iTeh STANDARD PREVIEW
(standards.iteh.ai)

[SIST EN 848-1:2000/A1:2000](https://standards.iteh.ai/catalog/standards/sist/1ac6335c-caea-4dba-8263-fda7ff7b88d9/sist-en-848-1-2000-a1-2000)
<https://standards.iteh.ai/catalog/standards/sist/1ac6335c-caea-4dba-8263-fda7ff7b88d9/sist-en-848-1-2000-a1-2000>