



**SLOVENSKI STANDARD**  
**SIST EN 13985:2003**

**01-november-2003**

---

**Obdelovalni stroji - Varnost - Škarje**

Machine tools - Safety - Guillotine shears

Werkzeugmaschinen - Sicherheit - Tafelscheren

Machines-outils - Sécurité - Cisailles guillotines

**iTeh STANDARD PREVIEW**  
**(standards.iteh.ai)**

**Ta slovenski standard je istoveten z: EN 13985:2003**

SIST EN 13985:2003  
<https://standards.iteh.ai/catalog/standards/sist/28075550-15b2-4369-8b18-dc04c4d355d4/sist-en-13985-2003>

---

**ICS:**

25.120.10	Kovaški stroji. Stiskalnice. Škarje	Forging equipment. Presses. Shears
-----------	--	---------------------------------------

**SIST EN 13985:2003**

**en**

**iTeh STANDARD PREVIEW**  
**(standards.iteh.ai)**

[SIST EN 13985:2003](#)

<https://standards.iteh.ai/catalog/standards/sist/28075530-15b2-4369-8b18-dc04c4d355d4/sist-en-13985-2003>

EUROPEAN STANDARD  
NORME EUROPÉENNE  
EUROPÄISCHE NORM

**EN 13985**

January 2003

ICS 25.120.10

English version

## Machine tools - Safety - Guillotine shears

Machines-outils - Sécurité - Cisailles guillotines

Werkzeugmaschinen - Sicherheit - Tafelscheren

This European Standard was approved by CEN on 14 November 2002.

CEN members are bound to comply with the CEN/CENELEC Internal Regulations which stipulate the conditions for giving this European Standard the status of a national standard without any alteration. Up-to-date lists and bibliographical references concerning such national standards may be obtained on application to the Management Centre or to any CEN member.

This European Standard exists in three official versions (English, French, German). A version in any other language made by translation under the responsibility of a CEN member into its own language and notified to the Management Centre has the same status as the official versions.

CEN members are the national standards bodies of Austria, Belgium, Czech Republic, Denmark, Finland, France, Germany, Greece, Hungary, Iceland, Ireland, Italy, Luxembourg, Malta, Netherlands, Norway, Portugal, Slovakia, Spain, Sweden, Switzerland and United Kingdom.

**(standards.iteh.ai)**

SIST EN 13985:2003

<https://standards.iteh.ai/catalog/standards/sist/28075530-15b2-4369-8b18-dc04c4d355d4/sist-en-13985-2003>



EUROPEAN COMMITTEE FOR STANDARDIZATION  
COMITÉ EUROPÉEN DE NORMALISATION  
EUROPÄISCHES KOMITEE FÜR NORMUNG

Management Centre: rue de Stassart, 36 B-1050 Brussels

## Contents

	page
Foreword.....	3
<b>1 Scope .....</b>	<b>4</b>
<b>2 Normative references .....</b>	<b>4</b>
<b>3 Terms, definitions and abbreviations .....</b>	<b>6</b>
<b>3.1 Terms and definitions.....</b>	<b>6</b>
<b>3.2 Abbreviations .....</b>	<b>8</b>
<b>4 List of significant hazards.....</b>	<b>8</b>
<b>5 Safety requirements and/or protective measures .....</b>	<b>12</b>
<b>5.1 General.....</b>	<b>12</b>
<b>5.2 Basic design considerations .....</b>	<b>13</b>
<b>5.3 Mechanical hazards in the blade and associated area .....</b>	<b>16</b>
<b>5.4 The control and monitoring system.....</b>	<b>23</b>
<b>5.5 Tool-setting, trial strokes, maintenance and lubrication.....</b>	<b>25</b>
<b>5.6 Mechanical hazards - Other .....</b>	<b>26</b>
<b>5.7 Slips, trips and falls .....</b>	<b>26</b>
<b>5.8 Protection against other hazards .....</b>	<b>26</b>
<b>6 Verification of the safety requirements and/or protective measures .....</b>	<b>31</b>
<b>7 Information for use .....</b>	<b>36</b>
<b>7.1 Marking .....</b>	<b>36</b>
<b>7.2 Instruction handbook .....</b>	<b>37</b>
<b>Annex A (normative) Calculation of minimum safety distances .....</b>	<b>39</b>
<b>Annex B (normative) The response time of the redundant hydraulic/pneumatic systems .....</b>	<b>41</b>
<b>Annex C (informative) Example of a hydraulic control circuit for a guillotine shear provided with fixed guards or light curtain .....</b>	<b>42</b>
<b>Annex D (normative) Conditions for noise measurement of guillotine shears .....</b>	<b>44</b>
<b>Annex ZA (informative) Relationship of this standard with EC Directives.....</b>	<b>45</b>
<b>Bibliography .....</b>	<b>46</b>

## Foreword

This document (EN 13985:2003) has been prepared by Technical Committee CEN/TC 143 "Machine tools - Safety", the secretariat of which is held by SNV.

This European Standard shall be given the status of a national standard, either by publication of an identical text or by endorsement, at the latest by July 2003, and conflicting national standards shall be withdrawn at the latest by July 2003.

This document has been prepared under a mandate given to CEN by the European Commission and the European Free Trade Association, and supports essential requirements of EC Directive(s).

For relationship with EC directive(s), see informative Annex ZA, which is an integral part of this document.

Organisation contributing to the preparation of this European Standard include the European Manufacturer Association CECIMO.

NOTE The safety requirements related to the use of PES or PPS will be dealt with at its next revision.

The European Standards produced by CEN/TC 143 are particular to machine tools and complement the relevant A and B standards on the subject of general safety (see Introduction of EN 292-1:1991 for a description of A, B and C standards).

(standards.iteh.ai)

Annexes A, B and D are normative. Annex C is informative.

According to the CEN/CENELEC Internal Regulations, the national standards organizations of the following countries are bound to implement this European Standard: Austria, Belgium, Czech Republic, Denmark, Finland, France, Germany, Greece, Hungary, Iceland, Ireland, Italy, Luxembourg, Malta, Netherlands, Norway, Portugal, Slovakia, Spain, Sweden, Switzerland and the United Kingdom.

## 0 Introduction

This European Standard has been prepared to be a harmonised standard to provide one means of conforming to the essential safety requirements of the "Machinery" Directive and associated EFTA Regulations. It is a C-type standard as described in EN 1070:1998.

The machinery concerned and the extent to which hazards, hazardous situations and events are covered are indicated in the scope of this standard. When provisions of this C type standard are different from those which are stated in A or B standards, the provision of this C type standard take precedence over the provisions of the other standards for machines that have been designed and built according to the provisions of this C type standard.

Complementary guidance is given in the A and B standards to which reference is made in the text (see clause 2). The figures are intended to be examples only and not to give the only interpretation of the text.

The requirements of this European Standard concern designers, manufacturers, suppliers and importers of machines described in the scope.

This standard also includes information to be provided by the manufacturer to the user.

**EN 13985:2003 (E)****1 Scope**

**1.1** This European Standard specifies technical safety requirements and measures to be adopted by persons undertaking the design as defined in 3.11 of EN 292-1:1991, manufacture and supply of guillotine shears which are intended to work cold metal or material partly of cold metal as defined in 3.1.7 and hereafter referred as machines.

**1.2** This standard also covers guillotine shears whose primary intended use is to work cold metal, which are to be used in the same way to work other sheet materials (e.g. cardboard, plastic, rubber, leather).

**1.3** The requirements in this standard take account of intended use, as defined in 3.12 of EN 292-1:1991. This standard presumes access to the guillotine shear from all directions, deals with the hazards described in clause 4, and specifies the safety requirements and/or protective measures for both the operator and other exposed persons.

**1.4** This standard also applies to ancillary devices which are an integral part of the guillotine shear. This standard also applies to machines which are integrated into an automatic production line where the hazards and risk arising are comparable to those of machines working separately.

**1.5** This standard includes guillotine shears in which energy is imparted to the blade by a number of means. e.g.:

- a) mechanically driven from a motor through a friction clutch;
- b) through a direct drive motor and brake;
- c) through hydraulic pressure;
- d) through pneumatic pressure.

**ITeh STANDARD PREVIEW**  
(standards.iteh.ai)

**1.6** This standard does not cover machines whose principal designed purpose is:

- a) cutting in other than a straight line (e.g. at nibbling machines);
- b) cutting by continuous action at crocodile shears (see 3.4).

**1.7** This standard does not cover the safety requirements related to the use of PES or PPS. They will be dealt with at its next revision.

**1.8** This standard is not applicable to machines which are manufactured before the date of publication of this document by CEN.

**2 Normative references**

This European Standard incorporates by dated or undated reference, provisions from other publications. These normative references are cited at the appropriate places in the text, and the publications are listed hereafter. For dated references, subsequent amendments to or revisions of any of these publications apply to this European Standard only when incorporated in it by amendment or revision. For undated references, the latest edition of the publication referred to applies (including amendments).

EN 292-1:1991, *Safety of machinery – Basic concepts, general principles for design – Part 1: Basic terminology, methodology.*

EN 292-2:1991, *Safety of machinery – Basic concepts, general principles for design – Part 2: Technical principles and specifications.*

EN 294:1992, *Safety of machinery – Safety distance to prevent danger zones being reached by the upper limbs.*

EN 418:1992, *Safety of machinery – Emergency stop equipment, functional aspects – Principles for design.*

EN 563, *Safety of machinery – Temperatures of touchable surfaces – Ergonomics data to establish temperature limit values for hot surfaces.*

EN 614-1, *Safety of machinery – Ergonomic design principles – Part 1: Terminology and general principles.*

EN 894-2:1997, *Safety of machinery – Ergonomic requirements for the design of displays and control actuators – Part 2: Displays.*

EN 894-3:2000, *Safety of machinery – Ergonomic requirements for the design of displays and control actuators – Part 3: Control actuators.*

EN 953:1997, *Safety of machinery – Guards – General requirements for the design and construction of fixed and movable guards.*

EN 954-1:1996, *Safety of machinery – Safety related parts of control systems – Part 1: General principles for design.*

EN 982:1996, *Safety of machinery – Safety requirements for fluid power systems and their components – Hydraulics.*

EN 983:1996, *Safety of machinery – Safety requirements for fluid power systems and their components – Pneumatics.*

EN 999:1998, *Safety of machinery – The positioning of protective equipment in respect to approach speeds of parts of the human body.*

prEN 1005-2, *Safety of machinery – Human physical performance – Part 2: Manual handling of machinery and component parts of machinery.*

EN 1037:1995, *Safety of machinery – Prevention of unexpected started up.*

EN 1050:1996, *Safety of machinery – Principles for risk assessment.*

EN 1070:1998, *Safety of machinery – Terminology.*

EN 1088:1995, *Safety of machinery – Interlocking devices associated with guards – Principles for design and selection.*

EN 1837:1999, *Safety of machinery – Integral lighting of machines.*

EN ISO 3746:1995, *Acoustics – Determination of sound power levels of noise sources using sound pressure – Survey method using an enveloping measurement surface over a reflecting plane (ISO 3746:1995).*

EN ISO 4871:1996, *Acoustics – Declaration and verification of noise emission values of machinery and equipment (ISO 4871:1996).*

EN ISO 11202:1995, *Acoustics – Noise emitted by machinery and equipment – Measurement of emissions of sound pressure levels at the work station and other specified positions – Survey method in situ (ISO 11202:1995).*

EN ISO 11688-1:1998, *Acoustics – Recommended practice for the design of low-noise machinery and equipment – Part 1: Planning (ISO/TR 11688-1:1995).*

EN ISO 11688-2:2000, *Acoustics – Recommended practice for the design of low-noise machinery and equipment – Part 2: Introduction to the physics of low-noise design (ISO/TR 11688-2:1998).*

EN ISO 14122-1, *Safety of machinery – Permanent means of access to machinery – Part 1: Choice of fixed means of access between two levels (ISO 14122-1:2001).*

EN ISO 14122-2, *Safety of machinery – Permanent means of access to machinery – Part 2: Working platforms and walkways (ISO 14122-2:2001).*

**EN 13985:2003 (E)**

EN ISO 14122-3, *Safety of machinery – Permanent means of access to machinery – Part 3: Stairs, stepladders and guard-rails (ISO 14122-3:2001)*.

prEN ISO 14122-4, *Safety of machinery – Permanent means of access to machines and industrial plants - Part 4: Fixed ladders (ISO/FDIS 14122-4:1999)*.

EN 60204-1:1997, *Safety of machinery – Electrical equipment of machines – Part 1: General requirements (IEC 60204-1:1997)*.

EN 60529, *Degrees of protection provided by enclosures (IP code) (IEC 60529:1989)*.

EN 60825-1, *Safety of laser products – Part 1: Equipment classification, requirements and user's guide (IEC 60825-1:1993)*.

EN 61310-2:1995, *Safety of machinery – Indication, marking and actuation – Part 2: Requirements for marking (IEC 61310-2:1995)*.

EN 61496-1:1997, *Safety of machinery – Electro-sensitive protective equipment – Part 1: General requirements and tests (IEC 61496-1:1997)*.

prEN 61496-2:1997, *Safety of machinery – Electrosensitive protective equipment – Part 2: Particular requirements for equipment using active optoelectronic protective devices (IEC 61469-2)*.

**3 Terms, definitions and abbreviations****3.1 Terms and definitions**

For the purposes of this European Standard, the terms and definitions given in EN 1070:1998 and the following definitions apply. Further definitions are provided in relevant A and B standards and in annex A of EN 292-2:1991/A1:1995.

**3.1.1****ancillary device**

device intended for use with the guillotine shear and integrated with it (e.g. devices for lubrication, feed, ejection)

**3.1.2****beam**

main reciprocating guillotine shear member holding the top blade. The top blade can be guided either by direct slide (vertically up and down) or swinging beam

**3.1.3****clamp**

part of the machine which holds the sheet material in position on the work table during the cutting stroke. Also called hold-down or jack

**3.1.4****crocodile shears**

shears having a shearing action like that of scissors. Power is applied in an angular direction around the pivot and the action of the blades is guided only by the pivot

**3.1.5****cycle (operating cycle)**

movement completed by the moving parts from the cycle start position (normally the top dead centre) to the bottom dead centre and back to the cycle stop position (normally the top dead centre). The operating cycle includes all operations carried out during this movement



**3.1.6****dead centres**

points at which the moving blade, during its travel, is

- a) either at the end of the chosen closing stroke, known as the bottom dead centre (BDC),
- b) or at the end of the chosen opening stroke, known as the top dead centre (TDC)

**3.1.7****guillotine shears**

machine, sometimes known simply as a guillotine or shears, consisting of side frames bridged by a work table to which is fixed a bottom blade and a movable upper beam to which is fixed a top blade(s). The blades may also be of fixed or variable angle (i.e. the angular relationship between the top and bottom blades)

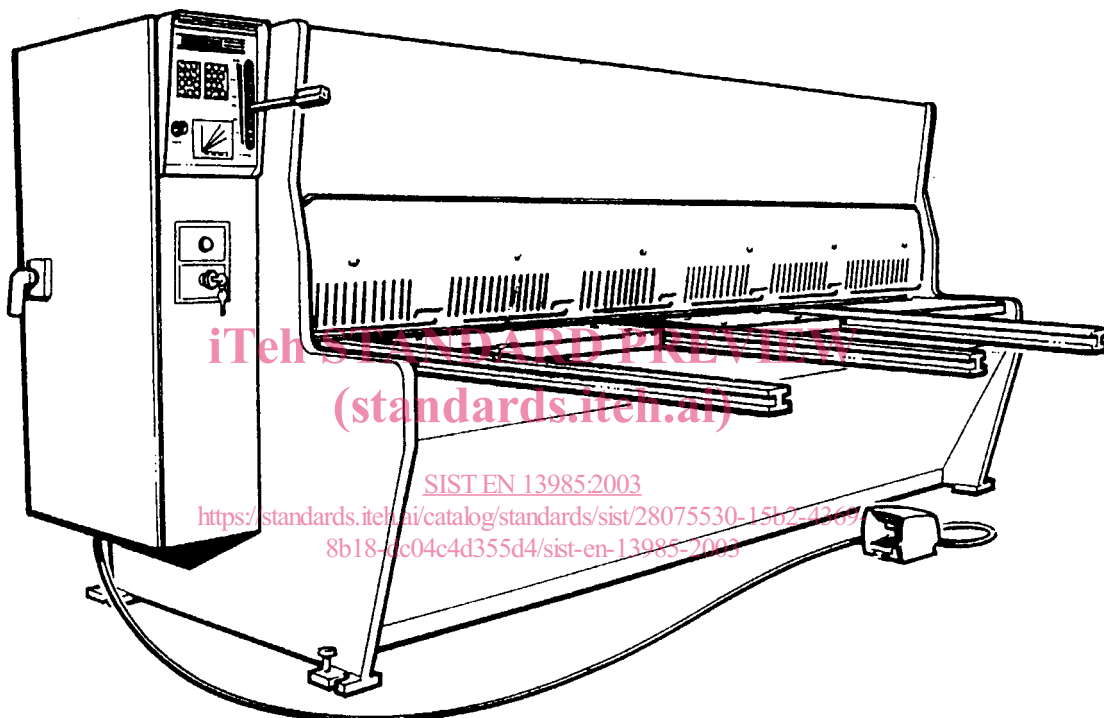

Figure 1 — Guillotine shear

**3.1.8****inching device; limited movement control device**

control device, the actuation of which permits only a limited amount of travel of a machine element, thus minimising risk as much as possible; further movement is precluded until there is subsequent and separate actuation of the control (see 3.23.8 of EN 292-1:1991)

**3.1.9****monitoring**

safety function which ensures that a protective measure is initiated if the ability of a component or an element to perform its function is diminished, or if the process conditions are changed in such a way that hazards are generated (see 3.7.6 of EN 292-2:1991)

**3.1.10****muting**

temporary automatic suspension of a safety function(s) by safety related parts of the control system (see 3.7 of EN 954-1:1996)

**EN 13985:2003 (E)****3.1.11****overall system stopping performance; overall response time**

time occurring from actuating the protective device to the cessation of hazardous motion, or to the machine assuming a safe condition

**3.1.12****redundancy**

application of more than one device or system, or part of a device or a system, with the objective of ensuring that, in the event of one failing to perform its function, another is available to perform that function (see 3.44 of EN 60204-1:1997 and 3.7.5 of EN 292-2:1991)

**3.2 Abbreviations**

**3.2.1 M Monitoring** (see 3.1.9)

**3.2.2 R Redundancy** (see 3.1.12)

**3.2.3 S Single channel**

**3.2.4 BDC Bottom dead centre** (see 3.1.6)

**3.2.5 TDC Top dead centre** (see 3.1.6)

**3.2.6 PES Programmable electronic systems**

**3.2.7 PPS Programmable pneumatic systems**

**3.2.8 AOPD Active opto-electronic protective devices**

**3.2.9 ESPE Electro-sensitive protective equipment**

STANDARD PREVIEW  
(standards.iteh.ai)  
SIST EN 13985:2003  
<https://standards.iteh.ai/catalog/standards/sist/28075530-15b2-4369-8b18-dc04c4d355d4/sist-en-13985-2003>

**4 List of significant hazards**

**4.1** The list of hazards contained in Table 1 is the result of a hazard identification, their associated danger zones and reference to protective measures for guillotine shears covered by the scope of this standard. The safety requirements and/or protective measures and information for use contained in clauses 5 and 7 are based on a risk assessment and deal with the identified hazards by either eliminating them or reducing the effects of the risks they generate.

**4.2** The risk assessment assumes foreseeable access from all directions, as well as unexpected and unintended strokes or gravity falls. Risks to both the operators and other persons who can have access to the danger zones are identified, taking into account hazards which can occur under various conditions of intended use (e.g. commissioning, setting, production, maintenance, repair, decommissioning, dismantling - see also 3.11 of EN 292-1:1991) during the life of the machine. The assessment includes an analysis of the effect of failure in the control system.

**4.3** The user of this standard (i.e. the designer, manufacturer, supplier) shall check that the list of significant hazards in Table 1 is complete for the machine under consideration. If the user determines that there are additional hazards then he shall analyse and evaluate the risks associated with these hazards in accordance with EN 1050 with particular attention to the intended use of the machine (e.g. commissioning, setting, production, maintenance, repair, decommissioning, dismantling - see also 3.11 of EN 292-1:1991), and its reasonably foreseeable misuse.

Table 1 — Significant hazards, danger zones, protective measures

No.	Hazards	Danger zone	Relevant clauses in EN 292-2/A1:1995	Relevant clauses in EN 292-1:1991	Protective measures: relevant clauses in this standard
1.0	<b>Mechanical hazards</b> Generated by machine parts or work-pieces Generated by accumulation of energy inside the machinery caused, for example, by: – elastic elements (springs) – liquids and gases under pressure	Blades and associated area: – between the moving blade and the work-piece – between the moving blade and the fixed blade – between moving and fixed parts of guillotine shear – between the table and work-piece – between the clamps and work-piece or table – between fixtures/positioning devices and work-piece – at power operated gauges – moving work-pieces,	1.3 (except 1.3.6)	4.2	
			1.5.3, 1.6.1, 1.6.3	4.2	5.2.6 5.5.2 5.3 5.5
1.1	Crushing hazard	– ejection or falling of work-pieces at the rear of guillotine shear, – rear moving sheet supports, – rear sheet conveyor, – sheet stacking unit From the hazardous event of falling objects	1.3 (except 1.3.6)	4.2.1	
1.2	Shearing hazard		1.4 (except 1.4.2.3) 1.5.14		
1.3	Cutting or severing hazard				
1.4	Entanglement hazard				
1.5	Drawing-in or trapping hazard				
1.6	Impact hazard	Moving parts of electrical, hydraulic and pneumatic equipment Motor and drive machinery – moving flywheels, belts, pulleys and other motor driven parts Mechanical handling device	1.3	4.2.1	5.6
1.9	High pressure fluid injection or ejection hazard	Hydraulic systems	1.3.2	4.2.1	5.8.3

(continued)

Table 1 (continued)

No.	Hazards	Danger zone	Relevant clauses in EN 292-2/A1:1995	Relevant clauses in EN 292-1:1991	Protective measures: relevant clauses in this standard
<b>2</b>	<b>Electrical hazards due to</b>				
2.1	Contact of persons with live parts (direct contact)	Electrical equipment	1.5.1, 1.6.3	4.3	5.8.3
2.2	Contact of persons with parts which have become live under faulty conditions (indirect contact)	Electrical equipment	1.5.1	4.3	
<b>3</b>	<b>Thermal hazards</b>				
3.1	Thermal hazards resulting in burns and scalds, by a possible contact of persons	Parts of the hydraulic system	1.5.5, 1.5.6, 1.5.7	4.4	5.2.1.5, 5.8.2
<b>4</b>	<b>Hazards generated by noise</b>				
4.1	Other physiological disorders (e.g. loss of balance, loss of awareness) hearing losses (deafness)	Falling of work-pieces at the rear of guillotine shear	1.5.8	4.5	5.8.5, 7.2.2 g)
<b>6</b>	<b>Hazards generated by radiation</b>				
6.5	Lasers	Any area at the guillotine shear where there is a risk due to laser beam. <a href="https://standards.iteh.ai/catalog/standards/sist/28075530-15b2-4369-8b18-dc04c4d355d4/sist-en-13985-2003">SIST EN 13985:2003</a>	1.5.12	4.7	5.8.6
<b>7.0</b>	<b>Hazards generated by materials and substances processed or used by machinery, for example:</b>				5.8.7
7.1	Hazards from contact with or inhalation of harmful fluids, gases, mists, fumes and dusts	Toxic materials used in the construction and intended use of the guillotine shear	1.1.3, 1.5.13, 1.6.5	4.8	5.8.7.1 5.8.7.2 5.8.7.3
<b>8.0</b>	<b>Hazards generated by neglecting ergonomic principles in machinery design, as e.g. from:</b>				
8.1	Unhealthy postures or excessive effort		1.1.2 d), 1.1.5, 1.6.2, 1.6.4	4.9	5.8.8
8.2	Inadequate consideration of hand-arm or foot-leg anatomy		1.1.2 d), 2.2		
8.4	Inadequate local lighting		1.1.4		5.8.8.3, 7.2.2d)

(continued)

Table 1 (continued)

No.	Hazards	Danger zone	Relevant clauses in EN 292-2/A1:1995	Relevant clauses in EN 292-1:1991	Protective measures: relevant clauses in this standard
8.6	Human error, human behaviour		1.1.2 d), 1.2.2, 1.2.5, 1.2.8, 1.5.4, 1.7	4.9	5.4.5.1, 5.4.3, 5.4.6
8.7	Inadequate design, location or identification of manual controls		1.2.2		5.4.3, 5.4.4, 5.4.5, 5.8.8.2
8.8	Inadequate design or location of visual display units		1.7.1		5.8.8.2
<b>10</b>	<b>Unexpected start-up, unexpected overrun/ over speed</b>				
10.1	Failure/disorder of the control system	Blades and associated area:	1.2.7, 1.6.3		5.2.1, 5.2.1.4, 5.2.1.7, 5.2.2, 5.4.1
10.2	Restoration of the energy supply after an interruption	<ul style="list-style-type: none"> <li>– between the moving blade and the work-piece</li> <li>– between the moving blade and the fixed blade</li> <li>– between the table and work-piece</li> <li>– between the clamps and work-piece or table</li> <li>– between fixtures/positioning devices and work-piece</li> <li>– safeguarding</li> <li>– at power operated gauges</li> </ul>	1.2.6		5.4, 7.2.2 o)

(continued)