



Designation: D 3987 – 85 (Reapproved 1999)

## Standard Test Method for Shake Extraction of Solid Waste with Water<sup>1</sup>

This standard is issued under the fixed designation D 3987; the number immediately following the designation indicates the year of original adoption or, in the case of revision, the year of last revision. A number in parentheses indicates the year of last reapproval. A superscript epsilon ( $\epsilon$ ) indicates an editorial change since the last revision or reapproval.

### 1. Scope

1.1 This test method covers a procedure for leaching of solid waste to obtain an aqueous solution to be used to determine the materials leached under the specified testing conditions.

1.2 This test method provides for the shaking of a known weight of waste with water of specified composition and the separation of the aqueous phase for analysis.

1.3 *This standard does not purport to address all of the safety problems, if any, associated with its use. It is the responsibility of the user of this standard to establish appropriate safety and health practices and determine the applicability of regulatory limitations prior to use.*

### 2. Referenced Documents

#### 2.1 ASTM Standards:

- C 471 Test Methods for Chemical Analysis of Gypsum and Gypsum Products<sup>2</sup>
- D 75 Practice for Sampling Aggregates<sup>3</sup>
- D 420 Practice for Investigating and Sampling Soil and Rock for Engineering Purposes<sup>4</sup>
- D 1129 Terminology Relating to Water<sup>5</sup>
- D 1193 Specification for Reagent Water<sup>5</sup>
- D 2216 Test Method for Laboratory Determination of Water (Moisture) Content of Soil and Rock<sup>4</sup>
- D 2234 Test Methods for Collection of a Gross Sample of Coal<sup>6</sup>
- D 3370 Practices for Sampling Water<sup>5</sup>
- E 122 Practice for Choice of Sample Size to Estimate a Measure of Quality for a Lot or Process<sup>7</sup>

### 3. Terminology Definitions

3.1 For definitions of terms used in this test method, see Terminology D 1129.

<sup>1</sup> This test method is under the jurisdiction of ASTM Committee D34 on Waste Management and is the direct responsibility of Subcommittee D34.01.04 on Waste Leaching Techniques.

Current edition approved Oct. 21, 1985. Published March 1986. Originally published as D 3987 – 81. Last previous edition D 3987 – 81.

<sup>2</sup> *Annual Book of ASTM Standards*, Vol 04.01.

<sup>3</sup> *Annual Book of ASTM Standards*, Vol 04.03.

<sup>4</sup> *Annual Book of ASTM Standards*, Vol 04.08.

<sup>5</sup> *Annual Book of ASTM Standards*, Vol 11.01.

<sup>6</sup> *Annual Book of ASTM Standards*, Vol 05.05.

<sup>7</sup> *Annual Book of ASTM Standards*, Vol 14.02.

### 4. Significance and Use

4.1 This test method is intended as a rapid means for obtaining an extract of solid waste. The extract may be used to estimate the release of certain constituents of the solid waste under the laboratory conditions described in this procedure.

4.2 This test method is not intended to provide an extract that is representative of the actual leachate produced from a solid waste in the field or to produce extracts to be used as the sole basis of engineering design.

4.3 This test method is not intended to simulate site-specific leaching conditions. It has not been demonstrated to simulate actual disposal site leaching conditions.

4.4 The intent of this test method is that the final pH of the extract reflect the interaction of the extractant with the buffering capacity of the solid waste.

4.5 The intent of this test method is that the water extraction simulate conditions where the solid waste is the dominant factor in determining the pH of the extract.

4.6 The test method produces an extract that is amenable to the determination of both major and minor constituents. When minor constituents are being determined, it is especially important that precautions are taken in sample storage and handling to avoid possible contamination of the samples.

4.7 This test method has been tested to determine its applicability to certain inorganic components in the solid waste. The test method has not been tested for applicability to organic substances and volatile matter (see 5.3).

4.8 The agitation technique, rate, and liquid-to-solid ratio specified in the procedure may not be suitable for extracting all types of solid wastes. (See Sections 7, 8, and the discussion in Appendix X1.)

### 5. Apparatus

5.1 *Agitation Equipment*, of any type that rotates about a central axis at a rate of 29 r/min, Fig. 1. (See discussion of agitation in Appendix X1.)

5.2 *Membrane Filter Assembly*—A borosilicate glass or stainless steel funnel with a flat, fritted base of the same material and membrane filters.

5.3 *Containers*, round, wide-mouth, of a composition suitable to the nature of the solid waste and the analyses to be performed, and constructed of materials that will not allow sorption of constituents of interest. One-gallon (or 4-L) containers should be used with 140-g samples and ½-gallon (or

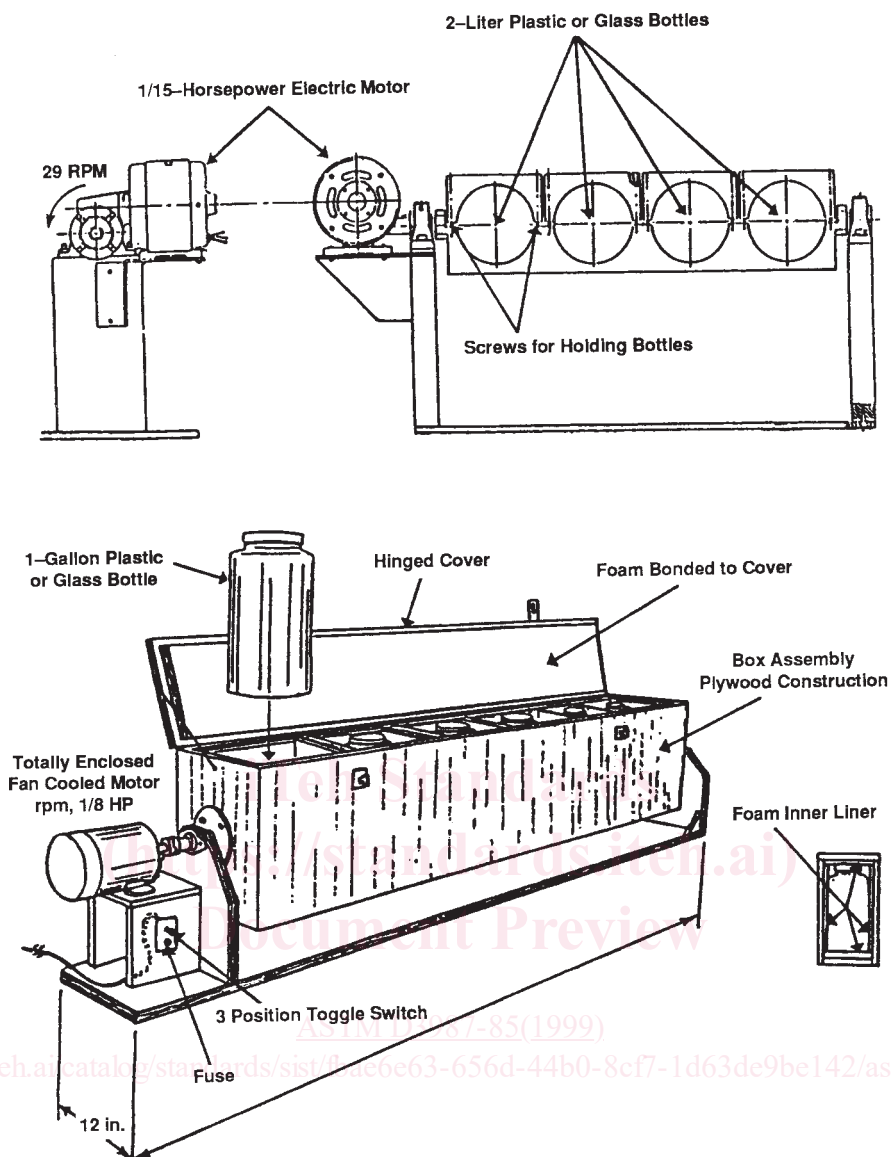

FIG. 1 Extractor

2-L) containers with 70-g samples. Multiples of these sizes may be used for larger samples. The containers should be of the same approximate geometry as the 2-L and 4-L bottles. These sizes were selected to establish suitable geometry and provide that the sample plus liquid would occupy approximately 80 to 90 % of the container. Containers must have a watertight closure. Containers for samples where gases may be released should be provided with a venting mechanism. (Note that the venting of the container has the potential to affect the concentration of volatile extracts in the extract.) Containers should be cleaned in a manner consistent with the analyses to be performed.

## 6. Reagents

6.1 *Purity of Reagents*—Reagent grade chemicals shall be used in all tests. Unless otherwise indicated, it is intended that

all reagents shall conform to the specifications of the American Chemical Society, where such specifications are available,<sup>8</sup> Other grades may be used, provided it is first ascertained that the reagent is of sufficiently high purity to permit its use without lessening the accuracy of the determination.

6.2 *Purity of Water*—Unless otherwise indicated, references to water shall be understood to mean Type IV reagent water at 18 to 27°C (Specification D 1193). The method by which the

<sup>8</sup> "Reagent Chemicals, American Chemical Society Specifications," Am. Chemical Soc., Washington, DC. For suggestions on the testing of reagents not listed by the American Chemical Society, see "Reagent Chemicals and Standards," by Joseph Rosin. D. Van Nostrand Co., Inc., New York, NY, and the "United States Pharmacopeia."