**Infusion equipment for medical use —
Part 7:
Caps made of aluminium-plastics
combinations for infusion bottles**

Matériel de perfusion à usage médical —

Partie 7: Capsules en combinaison aluminium-plastique pour flacons de perfusion

**iTeh STANDARD PREVIEW
(standards.iteh.ai)**

ISO 8536-7:2009

<https://standards.iteh.ai/catalog/standards/sist/5f82f278-bab7-48d9-8754-72a799d19641/iso-8536-7-2009>



PDF disclaimer

This PDF file may contain embedded typefaces. In accordance with Adobe's licensing policy, this file may be printed or viewed but shall not be edited unless the typefaces which are embedded are licensed to and installed on the computer performing the editing. In downloading this file, parties accept therein the responsibility of not infringing Adobe's licensing policy. The ISO Central Secretariat accepts no liability in this area.

Adobe is a trademark of Adobe Systems Incorporated.

Details of the software products used to create this PDF file can be found in the General Info relative to the file; the PDF-creation parameters were optimized for printing. Every care has been taken to ensure that the file is suitable for use by ISO member bodies. In the unlikely event that a problem relating to it is found, please inform the Central Secretariat at the address given below.

iTeh STANDARD PREVIEW
(standards.iteh.ai)

ISO 8536-7:2009

<https://standards.iteh.ai/catalog/standards/sist/5f82f278-bab7-48d9-8754-72a799d19641/iso-8536-7-2009>



COPYRIGHT PROTECTED DOCUMENT

© ISO 2009

All rights reserved. Unless otherwise specified, no part of this publication may be reproduced or utilized in any form or by any means, electronic or mechanical, including photocopying and microfilm, without permission in writing from either ISO at the address below or ISO's member body in the country of the requester.

ISO copyright office
Case postale 56 • CH-1211 Geneva 20
Tel. + 41 22 749 01 11
Fax + 41 22 749 09 47
E-mail copyright@iso.org
Web www.iso.org

Published in Switzerland

Foreword

ISO (the International Organization for Standardization) is a worldwide federation of national standards bodies (ISO member bodies). The work of preparing International Standards is normally carried out through ISO technical committees. Each member body interested in a subject for which a technical committee has been established has the right to be represented on that committee. International organizations, governmental and non-governmental, in liaison with ISO, also take part in the work. ISO collaborates closely with the International Electrotechnical Commission (IEC) on all matters of electrotechnical standardization.

International Standards are drafted in accordance with the rules given in the ISO/IEC Directives, Part 2.

The main task of technical committees is to prepare International Standards. Draft International Standards adopted by the technical committees are circulated to the member bodies for voting. Publication as an International Standard requires approval by at least 75 % of the member bodies casting a vote.

Attention is drawn to the possibility that some of the elements of this document may be the subject of patent rights. ISO shall not be held responsible for identifying any or all such patent rights.

ISO 8536-7 was prepared by Technical Committee ISO/TC 76, *Transfusion, infusion and injection equipment for medical and pharmaceutical use*.

This third edition cancels and replaces the second edition (ISO 8536-7:1999), Clause 2 of which has been updated.

iTeh STANDARD PREVIEW
(standards.iteh.ai)

ISO 8536 consists of the following parts, under the general title *Infusion equipment for medical use*:

- Part 1: *Infusion glass bottles*
<https://standards.iteh.ai/catalog/standards/sist/5f82f278-bab7-48d9-8754-72a799d19641/iso-8536-7-2009>
- Part 2: *Closures for infusion bottles*
- Part 3: *Aluminium caps for infusion bottles*
- Part 4: *Infusion sets for single use, gravity feed*
- Part 5: *Burette infusion sets for single use, gravity feed*
- Part 6: *Freeze drying closures for infusion bottles*
- Part 7: *Caps made of aluminium-plastics combinations for infusion bottles*
- Part 8: *Infusion equipment for use with pressure infusion apparatus*
- Part 9: *Fluid lines for use with pressure infusion equipment*
- Part 10: *Accessories for fluid lines for use with pressure infusion equipment*
- Part 11: *Infusion filters for use with pressure infusion equipment*
- Part 12: *Check valves*

Introduction

The materials from which infusion glass bottles (including elastomeric closures) are made are suitable primary packaging materials for storing infusion solutions until they are administered. However, in this part of ISO 8536, caps of aluminium-plastics combinations are not considered as primary packaging materials in direct contact with the infusion solution.

iTeh STANDARD PREVIEW (standards.iteh.ai)

[ISO 8536-7:2009](https://standards.iteh.ai/catalog/standards/sist/5f82f278-bab7-48d9-8754-72a799d19641/iso-8536-7-2009)

<https://standards.iteh.ai/catalog/standards/sist/5f82f278-bab7-48d9-8754-72a799d19641/iso-8536-7-2009>

Infusion equipment for medical use —

Part 7: Caps made of aluminium-plastics combinations for infusion bottles

1 Scope

This part of ISO 8536 specifies caps made of aluminium-plastics combinations intended for use on infusion glass bottles which are in accordance with ISO 8536-1.

2 Normative references

The following referenced documents are indispensable for the application of this document. For dated references, only the edition cited applies. For undated references, the latest edition of the referenced document (including any amendments) applies.

ISO 2768-1, *General tolerances — Part 1: Tolerances for linear and angular dimensions without individual tolerance indications*

ISO 8536-7:2009

<https://standards.iteh.ai/catalog/standards/sist/5f82f278-bab7-48d9-8754-72a79d1907f8/iso-8536-7-2009>

ISO 2768-2, *General tolerances — Part 2: Geometrical tolerances for features without individual tolerance indications*

ISO 8536-1, *Infusion equipment for medical use — Part 1: Infusion glass bottles*

ISO 8536-3, *Infusion equipment for medical use — Part 3: Aluminium caps for infusion bottles*

ISO 8872:2003, *Aluminium caps for transfusion, infusion and injection bottles — General requirements and test methods*

ISO 10985, *Caps made of aluminium-plastics combinations for infusion bottles and injection vials — Requirements and test methods*

3 Classification of type

Caps shall be classified as follows:

- Type ZB: aluminium cap with central opening and plastics component;
- Type ZD: aluminium cap with complete tear-off tab and plastics component.

4 Dimensions and tolerances

4.1 Dimensions

All cover versions (flat, ring-shaped or others) of caps shall meet the dimensions given in Figure 1 and Table 1.

NOTE The shape of the cap shown in Figure 1 is an example only.

4.2 Tolerances

Cap tolerances shall be in accordance with ISO 2768-1 and ISO 2768-2.

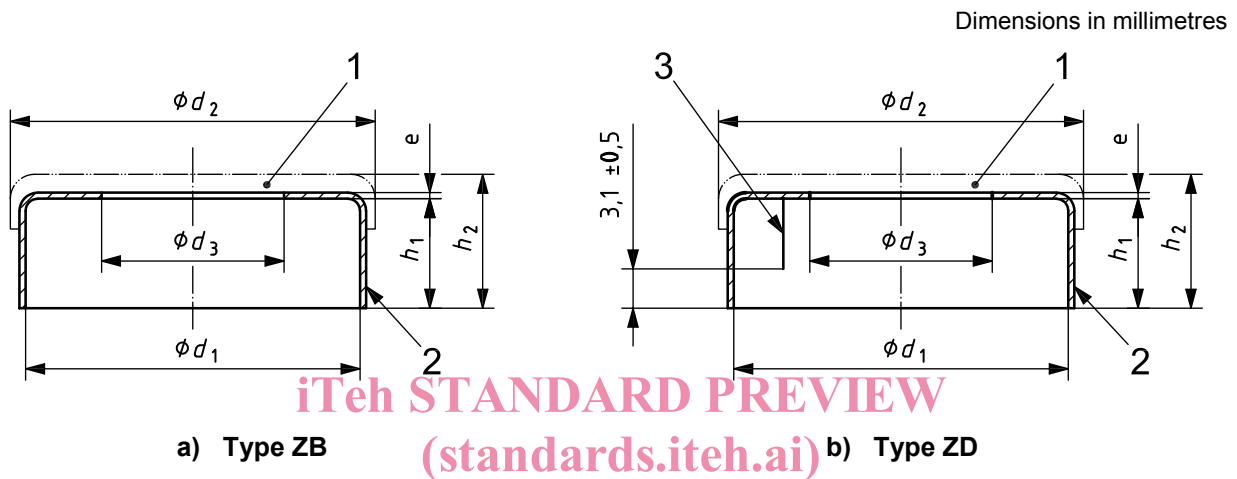

Key

- 1 plastics component
- 2 aluminium cap
- 3 score line

ISO 8536-7:2009
<https://standards.iteh.ai/catalog/standards/sist/5f82f278-bab7-48d9-8754-72a799d19641/iso-8536-7-2009>

Figure 1 — Configuration of cap

Table 1 — Dimensions of cap

Dimensions in millimetres

Nominal size	d_1	d_2^a		d_3^b		e^c		h_1	h_2^d	
	$+0,1$ $-0,05$	min.	max.	min.	max.	min.	max.	$\pm 0,25$	min.	max.
28	28,1	30,5	31,5	12	17	0,168	0,242	8,6 to 9,0	9	12
32	32,6	35,5	37	15	20			11,9	13	16

a The diameter, d_2 , shall be agreed upon between the manufacturer and the user. It shall not differ from the nominal value by more than $\pm 0,25$ mm. The extreme limits are given without tolerance.

b After plastics element removal.

c The thickness, e , shall be agreed upon between the manufacturer and the user. It shall not differ from the nominal value by more than $\pm 0,022$ mm. The extreme limits are given without tolerance.

d The height, h_2 , shall be agreed upon between the manufacturer and the user. It shall not differ from the nominal value by more than $\pm 0,4$ mm. The extreme limits are given without tolerance.

5 Designation

Aluminium-plastics caps shall be designated according to type.

The designation is expressed as the word “Cap”, followed by the number and part of this International Standard, followed by the type letters, followed by the nominal size of the cap.

EXAMPLE A type ZD aluminium-plastics cap of nominal size 32 complying with the requirements of this part of ISO 8536 is designated as follows:

Cap ISO 8536-7 - ZD - 32

6 Requirements

6.1 General requirements

6.1.1 The requirements for aluminium caps shall be in accordance with ISO 8536-3.

6.1.2 The requirements for plastics components and for the combination between the plastics component and the aluminium cap shall be in accordance with ISO 10985.

6.1.3 Construction elements which penetrate into the interior space of the aluminium cap shall not interfere with the sealing process.

6.2 Force required to remove tab

6.2.1 The maximum force required to remove the tab shall comply with Table 2.

ISO 8536-7:2009
<https://standards.iteh.ai/catalog/standards/sist/5822778-bab7-4849-8754-72a799d19641/iso-8536-7-2009>
Table 2 — Force required to remove plastics component and tear-off tab completely

Nominal size	Force to remove plastics component	Force to tear off tab completely
	max.	max.
28	40	30
32	60	40

Force in newtons

6.2.2 For incoming control, a minimum value for the tear-off tab removal force shall be agreed between the supplier and the user. The infusion caps shall also withstand a sterilization process in accordance with 5.1 of ISO 8872:2003.

7 Packaging

Packaging shall comply with the requirements of ISO 8872.

8 Marking

Marking shall be in accordance with ISO 8872 and the designation shall be as specified in Clause 5.

iTeh STANDARD PREVIEW
(standards.iteh.ai)

ISO 8536-7:2009

<https://standards.iteh.ai/catalog/standards/sist/5f82f278-bab7-48d9-8754-72a799d19641/iso-8536-7-2009>

ICS 11.040.20

Price based on 3 pages