**Road vehicles — Vehicle identification
number (VIN) — Content and structure**

*Véhicules routiers — Numéro d'identification des véhicules (VIN) —
Contenu et structure*

iTeh STANDARD PREVIEW
(standards.iteh.ai)

[ISO 3779:2009](https://standards.iteh.ai/catalog/standards/sist/7b5d7345-f5e1-405e-b0e3-162e3ad24f7d/iso-3779-2009)

[https://standards.iteh.ai/catalog/standards/sist/7b5d7345-f5e1-405e-b0e3-
162e3ad24f7d/iso-3779-2009](https://standards.iteh.ai/catalog/standards/sist/7b5d7345-f5e1-405e-b0e3-162e3ad24f7d/iso-3779-2009)



PDF disclaimer

This PDF file may contain embedded typefaces. In accordance with Adobe's licensing policy, this file may be printed or viewed but shall not be edited unless the typefaces which are embedded are licensed to and installed on the computer performing the editing. In downloading this file, parties accept therein the responsibility of not infringing Adobe's licensing policy. The ISO Central Secretariat accepts no liability in this area.

Adobe is a trademark of Adobe Systems Incorporated.

Details of the software products used to create this PDF file can be found in the General Info relative to the file; the PDF-creation parameters were optimized for printing. Every care has been taken to ensure that the file is suitable for use by ISO member bodies. In the unlikely event that a problem relating to it is found, please inform the Central Secretariat at the address given below.

iTeh STANDARD PREVIEW
(standards.iteh.ai)

ISO 3779:2009

<https://standards.iteh.ai/catalog/standards/sist/7b5d7345-f5e1-405e-b0e3-162e3ad24f7d/iso-3779-2009>



COPYRIGHT PROTECTED DOCUMENT

© ISO 2009

All rights reserved. Unless otherwise specified, no part of this publication may be reproduced or utilized in any form or by any means, electronic or mechanical, including photocopying and microfilm, without permission in writing from either ISO at the address below or ISO's member body in the country of the requester.

ISO copyright office
Case postale 56 • CH-1211 Geneva 20
Tel. + 41 22 749 01 11
Fax + 41 22 749 09 47
E-mail copyright@iso.org
Web www.iso.org

Published in Switzerland

Foreword

ISO (the International Organization for Standardization) is a worldwide federation of national standards bodies (ISO member bodies). The work of preparing International Standards is normally carried out through ISO technical committees. Each member body interested in a subject for which a technical committee has been established has the right to be represented on that committee. International organizations, governmental and non-governmental, in liaison with ISO, also take part in the work. ISO collaborates closely with the International Electrotechnical Commission (IEC) on all matters of electrotechnical standardization.

International Standards are drafted in accordance with the rules given in the ISO/IEC Directives, Part 2.

The main task of technical committees is to prepare International Standards. Draft International Standards adopted by the technical committees are circulated to the member bodies for voting. Publication as an International Standard requires approval by at least 75 % of the member bodies casting a vote.

Attention is drawn to the possibility that some of the elements of this document may be the subject of patent rights. ISO shall not be held responsible for identifying any or all such patent rights.

ISO 3779 was prepared by Technical Committee ISO/TC 22, *Road vehicles*.

This fourth edition cancels and replaces the third edition (ISO 3779:1983), which has been technically revised.

ITC STANDARD PREVIEW
(standards.iteh.ai)

[ISO 3779:2009](https://standards.iteh.ai/catalog/standards/sist/7b5d7345-f5e1-405e-b0e3-162e3ad24f7d/iso-3779-2009)

<https://standards.iteh.ai/catalog/standards/sist/7b5d7345-f5e1-405e-b0e3-162e3ad24f7d/iso-3779-2009>

Introduction

In the course of revising this International Standard, the following significant modifications have been made with respect to the previous edition:

- the separate clauses “Scope” and “Field of application” have been combined into a single Clause 1, and the subsequent clauses have been renumbered accordingly;
- the definition of **manufacturer** (3.5) has been revised in accordance with the state of the art;
- the content of 4.3 [“Vehicle descriptor section (VDS)”] has been clarified;
- Table 1 (“Characters used for designating the year”) has been amended.

iTeh STANDARD PREVIEW (standards.iteh.ai)

[ISO 3779:2009](https://standards.iteh.ai/catalog/standards/sist/7b5d7345-f5e1-405e-b0e3-162e3ad24f7d/iso-3779-2009)

<https://standards.iteh.ai/catalog/standards/sist/7b5d7345-f5e1-405e-b0e3-162e3ad24f7d/iso-3779-2009>

Road vehicles — Vehicle identification number (VIN) — Content and structure

1 Scope

This International Standard specifies the content and structure of a vehicle identification number (VIN) in order to establish, on a world-wide basis, a uniform identification numbering system for road vehicles.

This International Standard applies to motor vehicles, towed vehicles, motorcycles and mopeds as defined in ISO 3833.

2 Normative references

The following referenced documents are indispensable for the application of this document. For dated references, only the edition cited applies. For undated references, the latest edition of the referenced document (including any amendments) applies.

ISO 3780, *Road vehicles — World manufacturer identifier (WMI) code*

3 Terms and definitions

For the purposes of this document, the following terms and definitions apply.

3.1

vehicle identification number

VIN

structured combination of characters assigned to a vehicle by the manufacturer for identification purposes

3.2

world manufacturer identifier

WMI

first section of the vehicle identification number, which designates the manufacturer of the vehicle and is assigned to a vehicle manufacturer in order to allow identification of that manufacturer

NOTE When used in conjunction with the remaining sections of the VIN, the WMI ensures the uniqueness of the VIN for all vehicles manufactured in the world for a period of 30 years.

3.3

vehicle descriptor section

VDS

second section of the vehicle identification number, which provides information describing the general attributes of the vehicle

3.4

vehicle indicator section

VIS

third and final section of the vehicle identification number, which constitutes a combination of characters assigned by the manufacturer to distinguish one vehicle from another

ISO 3779:2009(E)

NOTE When used in conjunction with the VDS, the VIS ensures a unique designation of all vehicles produced by each manufacturer for a period of 30 years.

3.5 manufacturer

person, firm, or corporation that issues the certificate of conformity or that demonstrates compliance and assumes product liability for a vehicle ready for operation, independent of the location of the assembly plant

NOTE 1 Compliance implies conformity of production.

NOTE 2 The manufacturer is responsible for the uniqueness of the VIN.

NOTE 3 The manufacturer can delegate the responsibility for the production of the vehicles to a subsidiary company (see ISO 3780:2009, 4.3).

3.6 year

calendar year in which the vehicle was produced, or model year of the vehicle as determined by the manufacturer

3.7 divider

symbol, character or physical border that can be used to separate the sections of the vehicle identification number, or to define its limits

NOTE The limits of the VIN are its beginning and end.

ITEH STANDARD PREVIEW
(standards.iteh.ai)

4 Requirements

4.1 Basic content of the VIN

ISO 3779:2009

<https://standards.iteh.ai/catalog/standards/sist/7b5d7345-f5e1-405e-b0e3-162e3ad24f7d/iso-3779-2009>

The VIN shall consist of three sections:

- first section: the world manufacturer identifier (WMI) section;
- second section: the vehicle descriptor section (VDS);
- third section: the vehicle indicator section (VIS).

Annex A provides some examples of vehicle identification numbers.

4.2 World manufacturer identifier (WMI)

The WMI shall be the first section of the VIN and shall consist of three characters pre-assigned by the national organization of the country in which the manufacturer has its headquarters, as specified in ISO 3780.

4.3 Vehicle descriptor section (VDS)

The VDS shall be the second section of the VIN and shall consist of six characters (alphabetical or numerical, at the manufacturer's discretion). If the manufacturer does not use one or more of these character spaces, the unused spaces shall be filled by alphabetical or numerical characters of the manufacturer's choice. This section shall identify the general attributes of the vehicle. The coding and sequence of this section are determined by the manufacturer.

4.4 Vehicle indicator section (VIS)

The VIS shall be the third and final section of the VIN and shall consist of eight characters, the last four being numerical.

If the manufacturer chooses to designate year and/or plant in this section, it is recommended that the year be indicated by the first character of the VIS and the manufacturing plant by the second character. The recommended code to be used when designating year is indicated in Table 1.

In the case of a manufacturer producing fewer than 500 vehicles per year, the third, fourth and fifth characters of the VIS shall be assigned by the national organization (see ISO 3780:2009, 4.2) and shall identify the specific manufacturer.

4.5 Characters

The Arabic numerals and capital Roman letters to be used in the VIN shall be limited to the following:

1 2 3 4 5 6 7 8 9 0

A B C D E F G H J K L M N P R S T U V W X Y Z

The letters I, O and Q shall not be used.

4.6 Dividers

The selection of the specific divider to be used is at the discretion of the manufacturer, but it shall not be any character used in the VIN (see 4.5) or any character that could be confused with a VIN character. The divider shall be used at the limits of each line of the VIN, as indicated in 4.7.2, and may be used between sections. Dividers shall not be used on documentation. [ISO 3779:2009](https://standards.iteh.ai/catalog/standards/sist/7b5d7345-f5e1-405e-b0e3-162e3ad24f7d/iso-3779-2009)

<https://standards.iteh.ai/catalog/standards/sist/7b5d7345-f5e1-405e-b0e3-162e3ad24f7d/iso-3779-2009>

4.7 VIN display

4.7.1 The VIN printed on documents shall be shown on one line, without blanks.

4.7.2 The VIN as displayed on the vehicle or manufacturer's plate shall be represented on either one or two lines, without blanks and with no section being split.

Table 1 — Characters used for designating the year

| Year | Code | Year | Code | Year | Code | Year | Code |
|------|------|------|------|------|------|------|------|
| 1991 | M | 2001 | 1 | 2011 | B | 2021 | M |
| 1992 | N | 2002 | 2 | 2012 | C | 2022 | N |
| 1993 | P | 2003 | 3 | 2013 | D | 2023 | P |
| 1994 | R | 2004 | 4 | 2014 | E | 2024 | R |
| 1995 | S | 2005 | 5 | 2015 | F | 2025 | S |
| 1996 | T | 2006 | 6 | 2016 | G | 2026 | T |
| 1997 | V | 2007 | 7 | 2017 | H | 2027 | V |
| 1998 | W | 2008 | 8 | 2018 | J | 2028 | W |
| 1999 | X | 2009 | 9 | 2019 | K | 2029 | X |
| 2000 | Y | 2010 | A | 2020 | L | 2030 | Y |

Annex A (informative)

Examples of vehicle identification numbers

The examples in Figures A.1 to A.4 are for information only, and should not be assumed to represent the content of an actual VIN.

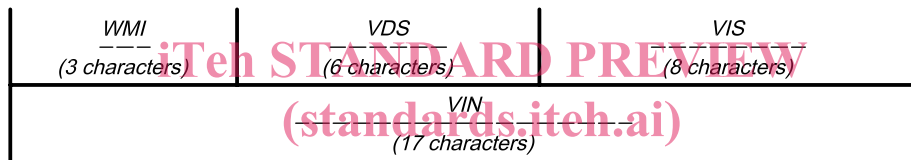
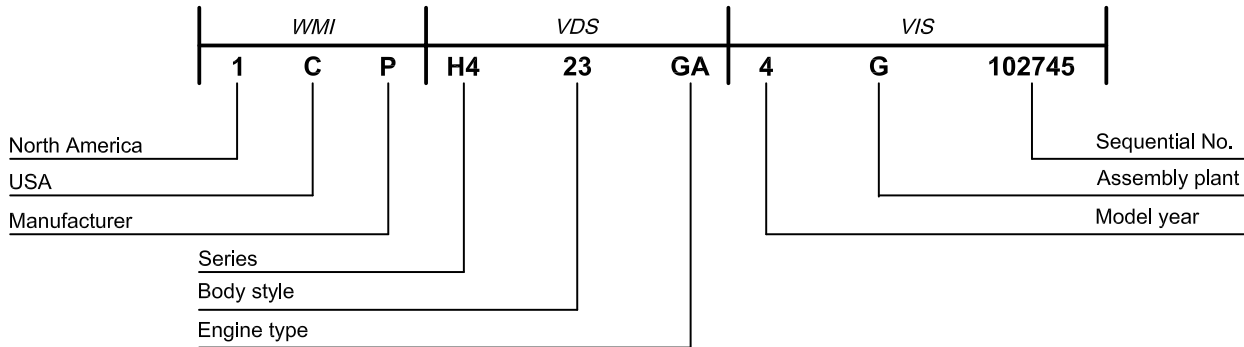

ISO 3779:2009
<https://standards.iteh.ai/catalog/standards/sist/7b5d7345-f5e1-405e-b0e3-162e3ad24f7d/iso-3779-2009>
Figure A.1 — Example of VIN (1)

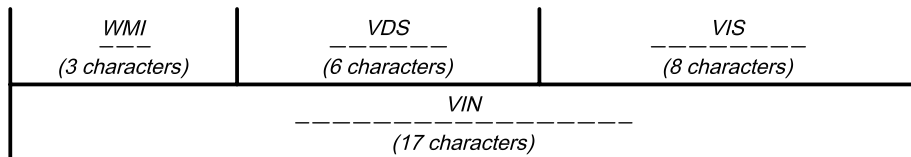
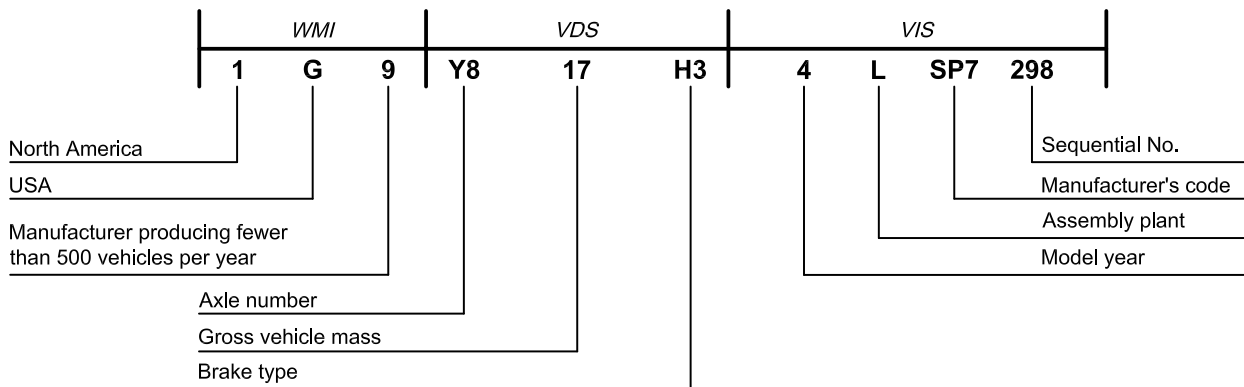
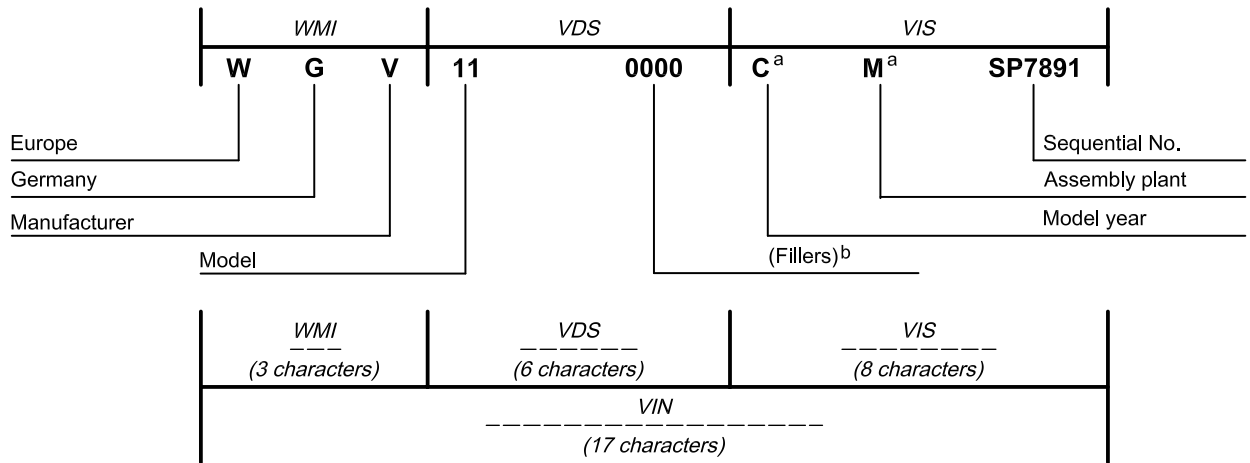

Figure A.2 — Example of VIN (2)



Key

- ^a Indication in accordance with 4.4.
- ^b See 4.3.

Figure A.3 — Example of VIN (3)

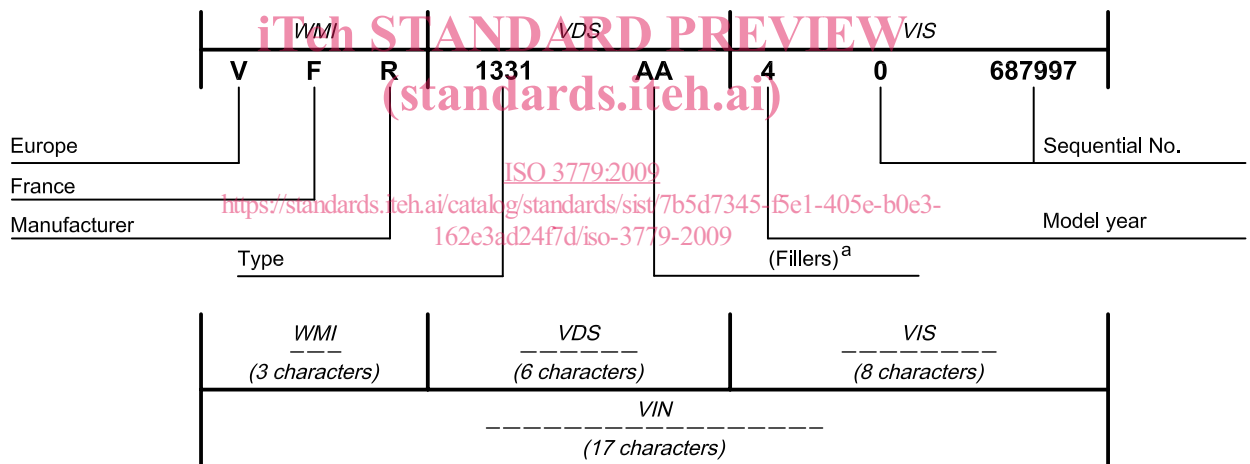

Key

- ^a See 4.3.

Figure A.4 — Example of VIN (4)