



SLOVENSKI STANDARD
SIST EN 704:1999

01-december-1999

Kmetijski stroji - Pobiralne naprave pri balirkah - Varnost

Agricultural machinery - Pick-up balers - Safety

Landmaschinen - Sammelpressen - Sicherheit

Matériel agricole - Ramasseuses-presses - Sécurité

Ta slovenski standard je istoveten z: EN 704:1999

SIST EN 704:1999
<https://standards.iteh.ai/catalog/standards/sist/f37ec09d-3ba5-4ed4-b13d-513f4950cd4c/sist-en-704-1999>

ICS:

65.060.50 Oprema za spravilo pridelkov Harvesting equipment

SIST EN 704:1999

en

iTeh STANDARD PREVIEW
(standards.iteh.ai)

SIST EN 704:1999

<https://standards.iteh.ai/catalog/standards/sist/f37ec09d-3ba5-4ed4-b13d-513f4950cd4c/sist-en-704-1999>

ICS 65.060.50

English version

Agricultural machinery - Pick-up balers - Safety

Matériel agricole - Ramasseuses-presses - Sécurité

Landmaschinen - Sammelpressen - Sicherheit

This European Standard was approved by CEN on 20 February 1999.

CEN members are bound to comply with the CEN/CENELEC Internal Regulations which stipulate the conditions for giving this European Standard the status of a national standard without any alteration. Up-to-date lists and bibliographical references concerning such national standards may be obtained on application to the Central Secretariat or to any CEN member.

This European Standard exists in three official versions (English, French, German). A version in any other language made by translation under the responsibility of a CEN member into its own language and notified to the Central Secretariat has the same status as the official versions.

CEN members are the national standards bodies of Austria, Belgium, Czech Republic, Denmark, Finland, France, Germany, Greece, Iceland, Ireland, Italy, Luxembourg, Netherlands, Norway, Portugal, Spain, Sweden, Switzerland and United Kingdom.

iTeh STANDARD PREVIEW
(standards.iteh.ai)

SIST EN 704:1999

<https://standards.iteh.ai/catalog/standards/sist/37cc05d-3ba5-4ed4-b13d-513f4950cd46/sist-en-704-1999>

EUROPEAN COMMITTEE FOR STANDARDIZATION
COMITÉ EUROPÉEN DE NORMALISATION
EUROPÄISCHES KOMITEE FÜR NORMUNG

Central Secretariat: rue de Stassart, 36 B-1050 Brussels

Contents list	Page
Foreword	3
0 Introduction	4
1 Scope	4
2 Normative references	4
3 Safety requirements and/or measures	5
3.1 General	5
3.2 Requirements for all types of balers	5
3.3 Requirements for rectangular balers	7
3.4 Requirements for round balers	11
4 Verification of safety requirements and/or measures	12
5 Information for use	12
5.1 Instruction handbook	12
5.2 Marking	13
Annex A (normative) List of hazards	14
Annex ZA (informative) Clauses of this European standard addressing essential requirements or other provisions of EU Directives	19

iTeh STANDARD PREVIEW
(standards.iteh.ai)

[SIST EN 704:1999](#)

<https://standards.iteh.ai/catalog/standards/sist/f37ec09d-3ba5-4ed4-b13d-513f4950cd4c/sist-en-704-1999>

Foreword

This European Standard has been prepared by Technical Committee CEN/TC 144 "Tractors and machinery for agriculture and forestry", the secretariat of which is held by AFNOR.

This European Standard shall be given the status of a national standard, either by publication of an identical text or by endorsement, at the latest by September 1999, and conflicting national standards shall be withdrawn at the latest by September 1999.

This European Standard has been prepared under a mandate given to CEN by the European Commission and the European Free Trade Association, and supports essential requirements of EU Directive(s).

For relationship with EU Directive(s), see informative Annex ZA, which is an integral part of this standard.

Annex A is normative and contains the "List of hazards".

According to the CEN/CENELEC Internal Regulations, the national standards organizations of the following countries are bound to implement this European Standard: Austria, Belgium, Czech Republic, Denmark, Finland, France, Germany, Greece, Iceland, Ireland, Italy, Luxembourg, Netherlands, Norway, Portugal, Spain, Sweden, Switzerland and the United Kingdom.

iTeh STANDARD PREVIEW
(standards.iteh.ai)

SIST EN 704:1999

<https://standards.iteh.ai/catalog/standards/sist/f37ec09d-3ba5-4ed4-b13d-513f4950cd4c/sist-en-704-1999>

0 Introduction

The extent to which hazards are covered is indicated in the scope of this standard. These hazards are specific to pick-up balers.

The hazards that are common to all the agricultural machines (self-propelled, mounted, semi-mounted and trailed) will be dealt with in a standard currently in preparation (prEN 1553).

1 Scope

This standard specifies safety requirements and their verification for design and construction of self-propelled and trailed pick-up balers independent of the shape or size of the bales formed.

It describes methods for the elimination or reduction of risks which need specific requirements for pick-up balers. It does not deal with hazards which are common to all agricultural machines particularly common hazards related to mobility, including those specific to self-propelled machines. These aspects will be dealt with in another standard produced by CEN/TC 144 (see introduction).

In addition, it specifies the type of information on safe working practices to be provided by the manufacturer.

The list of significant hazards dealt with in this standard is given in annex A. Annex A also indicates the hazards which have not been dealt with.

Environmental aspects have not been considered in this standard.

This standard applies primarily to machines which are manufactured after the date of issue of the standard.

2 Normative references

This European Standard incorporates by dated or undated reference, provisions from other publications. These normative references are cited at the appropriate places in the text and the publications are listed hereafter. For dated references, subsequent amendments to or revisions of any of these publications apply to this European Standard only when incorporated in it by amendment or revision. For undated references, the latest edition of the publication referred to applies.

EN 292-1	1991	Safety of machinery - Basic concepts, general principles for design - Part 1 : Basic terminology, methodology
EN 292-2	1991	Safety of machinery - Basic concepts, general principles for design - Part 2 : Technical principles and specifications (including amendment A1:1995)
EN 294	1992	Safety of machinery - Safety distances to prevent danger zones being reached by the upper limbs
prEN 1553	1998	Agricultural machinery - Agricultural self-propelled, mounted, semi-mounted and trailed machines - Common safety requirements

3 Safety requirements and/or measures

3.1 General

The machinery shall comply as appropriate with EN 292 for hazards which are not dealt with and especially with annex A of EN 292-2:1991/A1:1995 when EN 292 does not give precise requirements.

Unless otherwise specified in this standard, the machine shall comply with the requirements of prEN 1553:1998 and with tables 1, 3, 4 and 6 of EN 294:1992.

3.2 Requirements for all types of balers

3.2.1 Protection against hazards related to moving power transmission parts

To ensure protection against hazards related to accessible moving power transmission parts, the machine shall be fitted with fixed guards (according to 3.22.1 of EN 292-1:1991).

When frequent access is foreseen, the machine shall be fitted with guards needing a tool for their opening. These guards shall remain attached to the machine when opened (for example by means of hinges) and automatically lock in the closed position without the use of a tool.

If this type of guards is not used, the machine shall be fitted with :

- interlocking movable guards (according to 3.22.4 of EN 292-1:1991) ; or
- movable guards fitted with a device which prevent their opening so long as the parts are moving.

3.2.2 Drawbar

When the drawbar has separate positions, for transport and for working, it shall be provided with a mechanical or hydraulic locking device that requires an intentional action to change from transport to working position and from working to transport position (e.g pin, latch or hydraulic cylinder). When an hydraulic device is used, the drawbar shall remain locked in position if the hydraulic circuit fails.

3.2.3 Pick-up device

The protection of exposed persons against unintentional contact with any of the accessible moving parts at the front and at the sides of the pick-up device shall be ensured by a combination of barriers and fixed parts of the machine. The projection on an horizontal plane of these protective devices shall be continuous (see figures 1 and 2).

When the pick-up device is in the working position, these barriers shall be :

- a minimum of 230 mm in front of the most forward point of the tine path and at a height h of between 500 mm and 1 000 mm above the ground (see figure 1) ;
- a minimum of 150 mm from the sides of the tine path at a maximum height above the ground of 500 mm (see figure 1). If the tine path is totally covered by a part of the machine when viewed from the side (see figure 2), this barrier is not required.

NOTE 1 : The strength of the barriers will be dealt with within prEN 1553.

Dimensions in millimetres

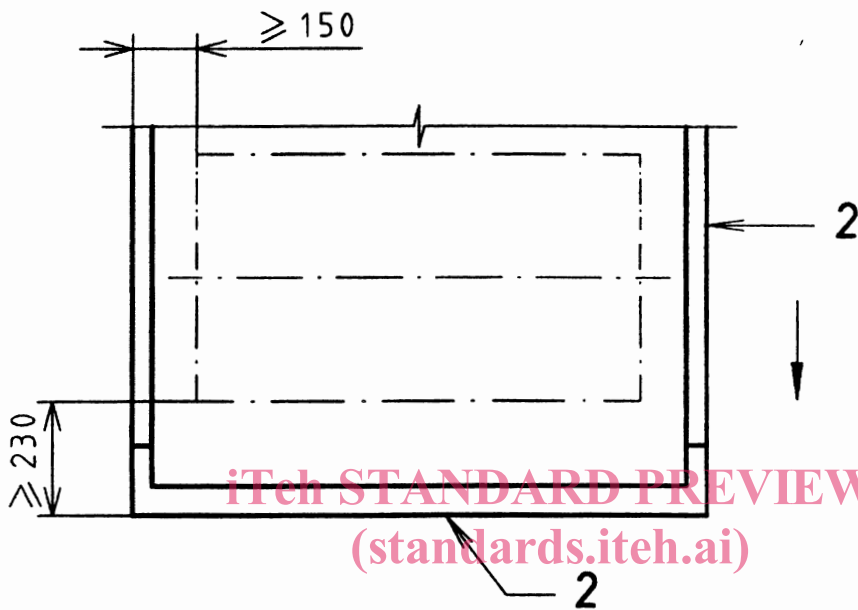
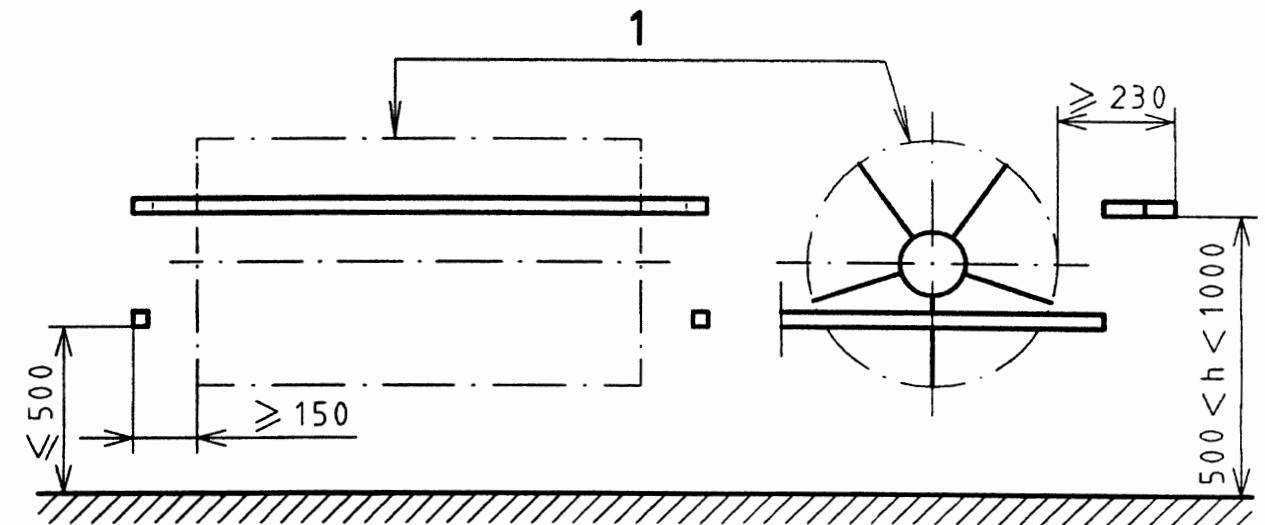

iTeh STANDARD PREVIEW
(standards.iteh.ai)

SIST EN 704:1999

<https://standards.iteh.ai/catalog/standards/sist/f37ec09d-3ba5-4ed4-b13d-513f4950cd4c/sist-en-704-1999>

- 1 - Tine path of the tool
- 2 - Barrier

NOTE 2 : This figure illustrates an example of protective devices complying with 3.2.3

Figure 1 : Guarding of the pick-up device

Dimensions in millimetres

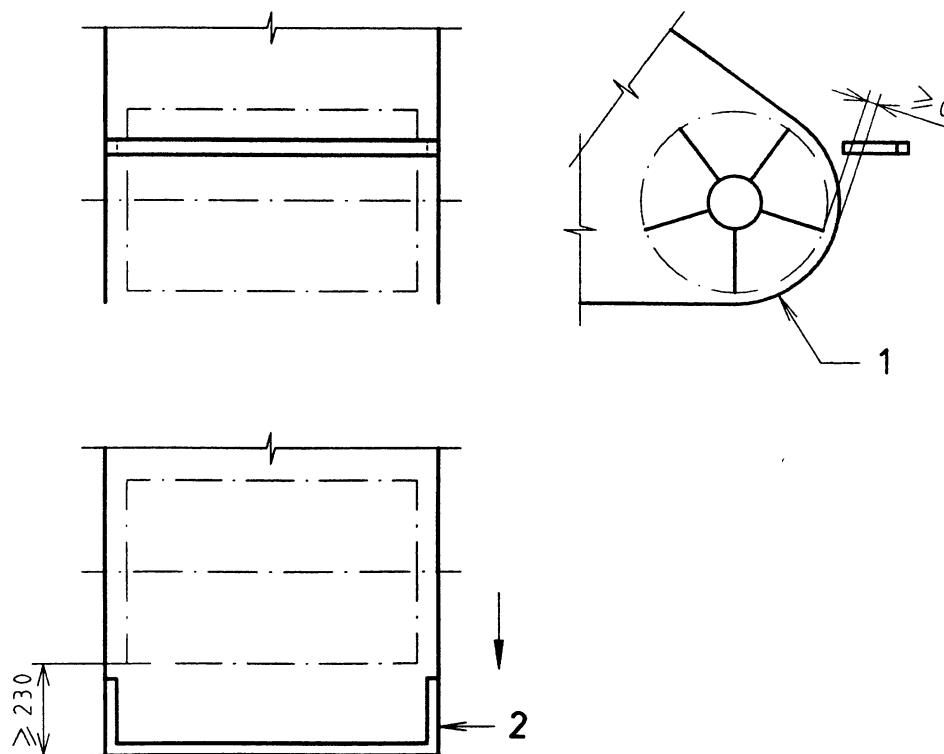

- 1 - Imperforate guard
(fixed part of the machine)
- 2 - Barrier

NOTE 3 : This figure illustrates an example of protective devices complying with 3.2.3

Figure 2 : Guarding of the pick-up device - Lateral protection ensured by an imperforate guard

3.2.4 Feeding elements

Crushing and shearing points located at a distance of less than 550 mm from the outer limit of the machine or from the extreme edges of the feeding channel shall be guarded according to 3.2.1.

(standards.iteh.ai)

3.3 Requirements for rectangular balers

3.3.1 Flywheel

<https://standards.iteh.ai/catalog/standards/sist/f37ec09d-3ba5-4ed4-b13d-513f4950cd4c/sist-en-704-1999>

Accessible parts of the flywheel shall be guarded according to 3.2.1.

If the flywheel guard is open underneath, a distance of at least 25 mm shall be provided between the flywheel and the guard ; this 25 mm shall extend from the lower edge of the guard for a distance of at least 120 mm ; the lower edge of the guard shall be located at a maximum distance of 800 mm from the ground (see figure 3).

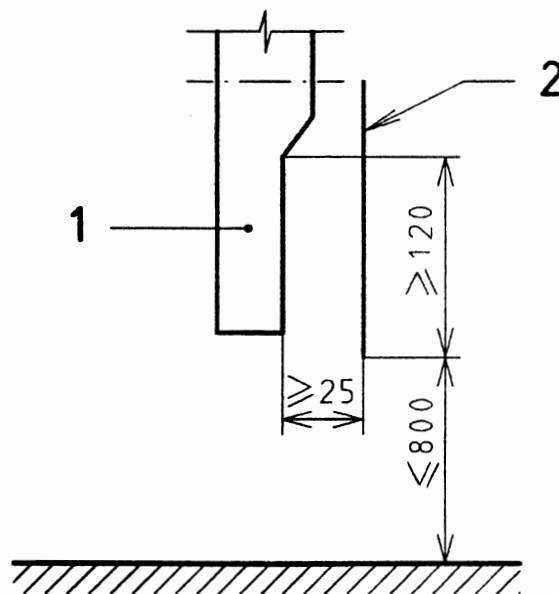

1 - Flywheel
2 - Guard

Figure 3 : Guarding of flywheel

For balers capable of forming bales with a cross section of 0,2 m² or greater :

- it shall be possible to immobilize the flywheel to avoid unintentional movement after it has stopped (for example by means of a brake or a mechanical restraining device) ;

and

- when the flywheel is positioned in such a way it is located above the crop flow when picking, the lower part of the flywheel may be exposed, providing the flywheel has a smooth surface and the upper part is guarded for at least 2/3 of the flywheel diameter measured vertically from the top.

iTeh STANDARD PREVIEW
(standards.iteh.ai)

3.3.2 Driving mechanism for the plunger

The connecting rod and crank mechanism shall be guarded according to 3.2.1. The side guard shall cover the extreme path of the crank when viewed from the side. If the guard of the rod and crank mechanism is open underneath, a distance of at least 25 mm shall be provided between the rod and the crank mechanism and the guard ; this 25 mm clearance shall extend from the edge of the guard for a distance of at least 120 mm (see figure 4).

If fixed parts of the baler are located directly below the crank path at a distance d less than 300 mm from it, then the side guard shall extend below these fixed parts (see figure 4).

Dimensions in millimetres

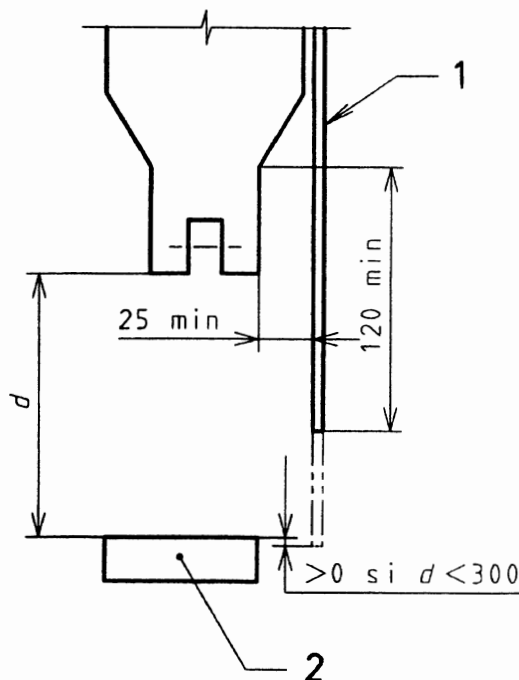

1 - Guard
2 - Fixed part of the baler

Figure 4 : Guarding of the driving mechanism for the plunger

3.3.3 Transmission parts of feeding elements

On balers capable of forming bales with a cross section smaller than 0,2 m², the transmission parts of the feeding elements, located in the upper part of the machine shall be guarded according to 3.2.1.

When the crushing or shearing points are located at less than 850 mm from the outer limit of the machine, a guard shall be fitted in such a way that its upper edge is located at a vertical distance of at least 130 mm above the extreme path of the crank.

Between the guard and the movable parts of the machine, there shall be a safety distance of at least 50 mm.

iTeh STANDARD PREVIEW
(standards.iteh.ai)

3.3.4 Tying mechanism

On the top and on the left and right hand sides, the knotter shall be guarded.

At the front and rear :

- when the knotter is not accessible from the ground (according to table 1 of EN 294:1992), no protection is required ;
- when the knotter is accessible from the ground (according to table 1 of EN 294:1992), the front part shall be guarded according to table 4 of EN 294:1992 and the rear part shall be guarded against unintentional contact in accordance with figure 5.

The guarding shall be achieved by means of :