



5 GHz RLAN; Receiver Blocking Performance

STANDARD PREVIEW
(standards.iteh.ai)
Full standard:
<https://standards.iteh.ai/catalog/standards/sist/725eae09-8b1b-48d8-9166-74752226fa6f/etsi-ts-103-521-v1.1.1-2017-04>

Reference

DTS/BRAN-00230012

Keywordsaccess, broadband, LAN, radio, receiver,
requirements, testing**ETSI**650 Route des Lucioles
F-06921 Sophia Antipolis Cedex - FRANCE

Tel.: +33 4 92 94 42 00 Fax: +33 4 93 65 47 16

Siret N° 348 623 562 00017 - NAF 742 C
Association à but non lucratif enregistrée à la
Sous-Préfecture de Grasse (06) N° 7803/88

Important noticeThe present document can be downloaded from:
<http://www.etsi.org/standards-search>

The present document may be made available in electronic versions and/or in print. The content of any electronic and/or print versions of the present document shall not be modified without the prior written authorization of ETSI. In case of any existing or perceived difference in contents between such versions and/or in print, the only prevailing document is the print of the Portable Document Format (PDF) version kept on a specific network drive within ETSI Secretariat.

Users of the present document should be aware that the document may be subject to revision or change of status. Information on the current status of this and other ETSI documents is available at
<https://portal.etsi.org/TB/ETSIDeliverableStatus.aspx>

If you find errors in the present document, please send your comment to one of the following services:
<https://portal.etsi.org/People/CommiteeSupportStaff.aspx>

Copyright Notification

No part may be reproduced or utilized in any form or by any means, electronic or mechanical, including photocopying and microfilm except as authorized by written permission of ETSI.

The content of the PDF version shall not be modified without the written authorization of ETSI.
The copyright and the foregoing restriction extend to reproduction in all media.

© European Telecommunications Standards Institute 2017.
All rights reserved.

DECT™, **PLUGTESTS™**, **UMTS™** and the ETSI logo are Trade Marks of ETSI registered for the benefit of its Members.
3GPP™ and **LTE™** are Trade Marks of ETSI registered for the benefit of its Members and of the 3GPP Organizational Partners.
oneM2M logo is protected for the benefit of its Members
GSM® and the GSM logo are Trade Marks registered and owned by the GSM Association.

Contents

Intellectual Property Rights	4
Foreword.....	4
Modal verbs terminology.....	4
Introduction	4
1 Scope	5
2 References	5
2.1 Normative references	5
2.2 Informative references.....	5
3 Definitions, symbols and abbreviations	5
3.1 Definitions	5
3.2 Symbols.....	5
3.3 Abbreviations	5
4 Receiver Blocking for 5 GHz RLANs.....	6
4.1 Receiver Blocking Specification	6
4.1.1 Definition.....	6
4.1.2 Performance Criteria.....	6
4.1.3 Limits.....	6
4.2 Receiver Blocking Test Method.....	6
4.2.1 Test conditions.....	6
4.2.2 Test Method.....	7
4.2.2.1 Conducted measurements.....	7
4.2.2.2 Radiated measurements.....	8
Annex A (informative): Change History	9
History	10

Intellectual Property Rights

IPRs essential or potentially essential to the present document may have been declared to ETSI. The information pertaining to these essential IPRs, if any, is publicly available for **ETSI members and non-members**, and can be found in ETSI SR 000 314: *"Intellectual Property Rights (IPRs); Essential, or potentially Essential, IPRs notified to ETSI in respect of ETSI standards"*, which is available from the ETSI Secretariat. Latest updates are available on the ETSI Web server (<https://ipr.etsi.org/>).

Pursuant to the ETSI IPR Policy, no investigation, including IPR searches, has been carried out by ETSI. No guarantee can be given as to the existence of other IPRs not referenced in ETSI SR 000 314 (or the updates on the ETSI Web server) which are, or may be, or may become, essential to the present document.

Foreword

This Technical Specification (TS) has been produced by ETSI Technical Committee Broadband Radio Access Networks (BRAN).

Modal verbs terminology

In the present document "**shall**", "**shall not**", "**should**", "**should not**", "**may**", "**need not**", "**will**", "**will not**", "**can**" and "**cannot**" are to be interpreted as described in clause 3.2 of the [ETSI Drafting Rules](#) (Verbal forms for the expression of provisions).

"**must**" and "**must not**" are **NOT** allowed in ETSI deliverables except when used in direct citation.

Introduction

5 GHz wireless access systems (WAS) including RLAN equipment are used in wireless local area networks which provide high speed data communications in between devices connected to the wireless infrastructure.

1 Scope

The present document specifies Receiver Blocking for 5 GHz RLAN devices.

2 References

2.1 Normative references

References are either specific (identified by date of publication and/or edition number or version number) or non-specific. For specific references, only the cited version applies. For non-specific references, the latest version of the referenced document (including any amendments) applies.

Referenced documents which are not found to be publicly available in the expected location might be found at <https://docbox.etsi.org/Reference>.

NOTE: While any hyperlinks included in this clause were valid at the time of publication, ETSI cannot guarantee their long term validity.

The following referenced documents are necessary for the application of the present document.

- [1] ETSI EN 301 893 (V1.8.1): "Broadband Radio Access Networks (BRAN); 5 GHz high performance RLAN; Harmonized EN covering the essential requirements of article 3.2 of the R&TTE Directive".

2.2 Informative references

References are either specific (identified by date of publication and/or edition number or version number) or non-specific. For specific references, only the cited version applies. For non-specific references, the latest version of the referenced document (including any amendments) applies.

NOTE: While any hyperlinks included in this clause were valid at the time of publication, ETSI cannot guarantee their long term validity.

The following referenced documents are not necessary for the application of the present document but they assist the user with regard to a particular subject area.

Not applicable.

3 Definitions, symbols and abbreviations

3.1 Definitions

For the purposes of the present document, the terms and definitions given in ETSI EN 301 893 [1] apply.

3.2 Symbols

For the purposes of the present document, the symbols given in ETSI EN 301 893 [1] apply.

3.3 Abbreviations

For the purposes of the present document, the abbreviations given in ETSI EN 301 893 [1] and the following apply:

PER Packet Error Rate

4 Receiver Blocking for 5 GHz RLANs

4.1 Receiver Blocking Specification

4.1.1 Definition

Receiver blocking is a measure of the capability of the equipment to receive a wanted signal on its operating channel without exceeding a given degradation due to the presence of an unwanted input signal (blocking signal) on frequencies other than those of the operating bands provided in ETSI EN 301 893 [1], clause 1.

4.1.2 Performance Criteria

The minimum performance criterion shall be a PER of less than or equal to 10 %. The manufacturer may declare alternative performance criteria as long as that is appropriate for the intended use of the equipment. See clause 4.2.1.

4.1.3 Limits

While maintaining the minimum performance criteria as defined in clause 4.1.2, the blocking levels at specified frequency offsets shall be equal to or greater than the limits defined in table 1.

Table 1: Receiver Blocking parameters

Wanted signal mean power from companion device (dBm)	Blocking signal frequency (MHz)	Blocking signal power (dBm) (see note 2)		Type of blocking signal
		Master or Slave with radar detection (as defined in ETSI EN 301 893 [1], table D.2, note 2)	Slave without radar detection (as defined in ETSI EN 301 893 [1], table D.2, note 2)	
$P_{\min} + 6$ dB	5 100	-53	-59	Continuous Wave
$P_{\min} + 6$ dB	4 900	-47	-53	Continuous Wave
	5 000 5 975			
NOTE 1: P_{\min} is the minimum level of the wanted signal (in dBm) required to meet the minimum performance criteria as defined clause 4.1.2 in the absence of any blocking signal.				
NOTE 2: The levels specified are levels in front of the UUT antenna. In case of conducted measurements, the same levels should be used at the antenna connector irrespective of antenna gain.				

4.2 Receiver Blocking Test Method

4.2.1 Test conditions

The UUT shall operate in its normal operational mode.

This test shall be performed on one operating channel within each of the sub-bands defined in ETSI EN 301 893 [1].

Devices which can change their operating frequency automatically (adaptive channel allocation), this function shall be disabled.

If the equipment can be configured to operate with different *Nominal Channel Bandwidths* (e.g. 20 MHz and 40 MHz) and different data rates, then the combination of the smallest channel bandwidth and the lowest data rate for this channel bandwidth, which still allows the equipment to operate as intended, shall be used. This mode of operation shall be aligned with the performance criteria defined in clause 4.1.2 as declared by the manufacturer and shall be described in the test report.

It shall be verified that this performance criteria as defined by the manufacturer is achieved during the blocking test.

4.2.2 Test Method

4.2.2.1 Conducted measurements

For systems using multiple receive chains only one chain needs to be tested. All other receiver inputs shall be terminated.

Figure 1 shows the test set-up which can be used for performing the receiver blocking test. The companion device may require appropriate shielding or may need to be put in a shielded room to prevent it may have a negative impact on the measurement.

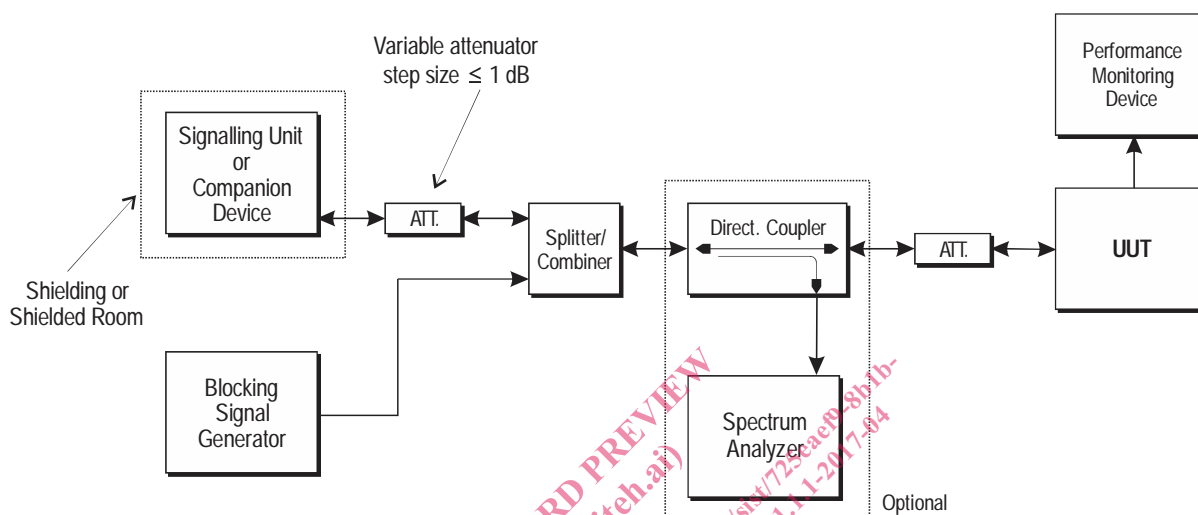

Figure 1: Test Set-up for receiver blocking

Step 1 to step 6 below define the procedure to verify the receiver blocking requirement as described in clause 4.1.

Step 1:

- The UUT shall be set to the first operating frequency to be tested.

Step 2:

- The blocking signal generator is set to the first frequency as defined in table 1.

Step 3:

- With the blocking signal generator switched off a communication link is set up between the UUT and the associated companion device using the test setup shown in figure 1. The attenuation of the variable attenuator shall be increased in 1 dB steps to a value at which the minimum performance criteria as specified in clause 4.1.2 is still met. The resulting level for the wanted signal at the input of the UUT is P_{\min} .
- This signal level (P_{\min}) is increased by 6 dB resulting in a new level ($P_{\min} + 6$ dB) of the wanted signal at the UUT receiver input.

Step 4:

- The level of the blocking signal at the UUT input is set to the level provided in table 1. It shall be verified and recorded in the test report that the performance criteria as specified in clause 4.1.2 are met.
- If the performance criteria as specified in clause 4.1.2 are met, the level of the blocking signal at the UUT may be further increased (e.g. in steps of 1 dB) until the level whereby the performance criteria as specified in clause 4.1.2 are no longer met. The highest level at which the performance criteria are met is recorded in the test report.

Step 5:

- Repeat step 4 for each remaining combination of frequency and level as specified in table 1.

Step 6:

- Repeat step 2 to step 5 with the UUT operating at the other operating frequencies at which the blocking test has to be performed.

4.2.2.2 Radiated measurements

When performing radiated measurements on equipment with dedicated antennas, measurements shall be repeated for each alternative dedicated antenna.

A test site as described in ETSI EN 301 893 [1], annex B and the measurement procedures as described in ETSI EN 301 893 [1], clause C.2 or clause C.3, shall be used.

The test procedure is further as described under clause 4.2.2.1.

The level of the blocking signal at the UUT referred to in clause 4.2.2.1, step 4 is assumed to be the level in front of the UUT antenna(s). The UUT shall be positioned with its main beam pointing towards the antenna radiating the blocking signal.

iTeh STANDARD PREVIEW
(standards.iteh.ai)
Full standard:
<https://standards.iteh.ai/catalog/standards/sist/725eae09-8b1b-48d8-9166-74752226fa6f/etsi-ts-103-521-v1.1.1-2017-04>

Annex A (informative): Change History

Date	Version	Information about changes
April 2017	V1.1.1	First published version.

iTeh STANDARD PREVIEW
(standards.iteh.ai)

Full standard:
<https://standards.iteh.ai/catalog/standards/sist/725eae09-8b1b-48d8-9166-74752226fa6f/etsi-ts-103-521-v1.1.1-2017-04>