



**5G;  
Study on New Radio (NR) access technology  
(3GPP TR 38.912 version 14.0.0 Release 14)**

*iTeh STANDARD PREVIEW  
(standards.iteh.ai)  
Full standard available on  
<https://standards.iteh.ai/catalog/standards/sis/e8ffde6d-d8b1-4a6b-8347-11bfde3163573/etsi-tr-138-912-v14.0-2017-05>*

## Reference

---

DTR/TSGR-0038912ve00

## Keywords

---

NR

**ETSI**

650 Route des Lucioles  
F-06921 Sophia Antipolis Cedex - FRANCE

---

Tel.: +33 4 92 94 42 00 Fax: +33 4 93 65 47 16

Siret N° 348 623 562 00017 - NAF 742 C  
Association à but non lucratif enregistrée à la  
Sous-Préfecture de Grasse (06) N° 7803/88

**Important notice**

The present document can be downloaded from:

<http://www.etsi.org/standards-search>

The present document may be made available in electronic versions and/or in print. The content of any electronic and/or print versions of the present document shall not be modified without the prior written authorization of ETSI. In case of any existing or perceived difference in contents between such versions and/or in print, the only prevailing document is the print of the Portable Document Format (PDF) version kept on a specific network drive within ETSI Secretariat.

Users of the present document should be aware that the document may be subject to revision or change of status. Information on the current status of this and other ETSI documents is available at

<https://portal.etsi.org/TB/ETSI/DeliverableStatus.aspx>

If you find errors in the present document, please send your comment to one of the following services:

<https://portal.etsi.org/People/CommitteeSupportStaff.aspx>

**Copyright Notification**

No part may be reproduced or utilized in any form or by any means, electronic or mechanical, including photocopying and microfilm except as authorized by written permission of ETSI.

The content of the PDF version shall not be modified without the written authorization of ETSI.

The copyright and the foregoing restriction extend to reproduction in all media.

© European Telecommunications Standards Institute 2017.

All rights reserved.

DECT™, PLUGTESTS™, UMTS™ and the ETSI logo are Trade Marks of ETSI registered for the benefit of its Members.

3GPP™ and LTE™ are Trade Marks of ETSI registered for the benefit of its Members and of the 3GPP Organizational Partners.

oneM2M logo is protected for the benefit of its Members

GSM® and the GSM logo are Trade Marks registered and owned by the GSM Association.

---

## Intellectual Property Rights

IPRs essential or potentially essential to the present document may have been declared to ETSI. The information pertaining to these essential IPRs, if any, is publicly available for **ETSI members and non-members**, and can be found in ETSI SR 000 314: *"Intellectual Property Rights (IPRs); Essential, or potentially Essential, IPRs notified to ETSI in respect of ETSI standards"*, which is available from the ETSI Secretariat. Latest updates are available on the ETSI Web server (<https://ipr.etsi.org/>).

Pursuant to the ETSI IPR Policy, no investigation, including IPR searches, has been carried out by ETSI. No guarantee can be given as to the existence of other IPRs not referenced in ETSI SR 000 314 (or the updates on the ETSI Web server) which are, or may be, or may become, essential to the present document.

---

## Foreword

This Technical Report (TR) has been produced by ETSI 3rd Generation Partnership Project (3GPP).

The present document may refer to technical specifications or reports using their 3GPP identities, UMTS identities or GSM identities. These should be interpreted as being references to the corresponding ETSI deliverables.

The cross reference between GSM, UMTS, 3GPP and ETSI identities can be found under <http://webapp.etsi.org/key/queryform.asp>.

---

## Modal verbs terminology

In the present document "**should**", "**should not**", "**may**", "**need not**", "**will**", "**will not**", "**can**" and "**cannot**" are to be interpreted as described in clause 3.2 of the [ETSI Drafting Rules](#) (Verbal forms for the expression of provisions).

"**must**" and "**must not**" are **NOT** allowed in ETSI deliverables except when used in direct citation.

# Contents

Intellectual Property Rights .....	2
Foreword.....	2
Modal verbs terminology.....	2
Foreword.....	7
1 Scope .....	8
2 References .....	8
3 Definitions, symbols and abbreviations .....	9
3.1 Definitions .....	9
3.2 Symbols.....	9
3.3 Abbreviations .....	9
4 Introduction .....	10
5 Deployment scenario.....	10
6 Forward compatibility .....	12
7 Radio interface protocol architecture for next generation radio.....	12
7.1 User plane.....	12
7.1.1 User plane protocol stack for NR.....	12
7.1.2 Bearer types for Dual Connectivity between LTE and NR.....	12
7.2 Control plane .....	14
7.2.1 Control plane protocol stack for NR.....	14
7.2.2 Control plane architecture for Dual Connectivity between LTE and NR.....	14
7.2.2.1 UE capability coordination between LTE and NR.....	15
8 Physical layer for next generation radio.....	16
8.1 Numerologies and frame structure .....	16
8.2 Downlink transmission scheme .....	18
8.2.1 Basic transmission scheme .....	18
8.2.1.1 Modulation scheme .....	18
8.2.1.2 Physical layer channel.....	18
8.2.1.2.1 Physical resource multiplexing.....	18
8.2.1.2.2 Data channel .....	18
8.2.1.2.3 Control channel .....	19
8.2.1.3 Waveform.....	19
8.2.1.4 Multiple access scheme.....	20
8.2.1.5 Channel coding .....	20
8.2.1.5.1 LDPC.....	20
8.2.1.5.2 Polar coding.....	21
8.2.1.6 Multi-antenna scheme .....	21
8.2.1.6.1 Beam management .....	21
8.2.1.6.2 MIMO schemes .....	24
8.2.1.6.3 CSI measurement and reporting .....	24
8.2.1.6.4 Reference signal related to multi-antenna scheme.....	28
8.2.1.6.4.1 CSI-RS.....	28
8.2.1.6.4.2 DM-RS.....	29
8.2.1.6.4.3 Phase-tracking RS (PT-RS) .....	29
8.2.1.6.5 Quasi-colocation (QCL) .....	29
8.2.1.6.6 Network coordination and advanced receiver .....	30
8.2.2 Physical layer procedure .....	30
8.2.2.1 Scheduling.....	30
8.2.2.2 HARQ .....	30
8.2.2.3 Initial access and mobility.....	31
8.2.2.3.1 Synchronization signal and DL broadcast signal/channel structure .....	31
8.2.2.3.2 Mobility .....	32

8.2.2.3.3	Paging.....	32
8.3	Uplink transmission scheme.....	32
8.3.1	Basic transmission scheme.....	32
8.3.1.1	Modulation scheme.....	32
8.3.1.2	Physical layer channel.....	32
8.3.1.2.1	Data channel.....	32
8.3.1.2.2	Control channel.....	33
8.3.1.3	Waveform.....	34
8.3.1.4	Multiple access scheme.....	34
8.3.1.5	Channel coding.....	34
8.3.1.5.1	LDPC.....	34
8.3.1.5.2	Polar coding.....	34
8.3.1.6	Multi-antenna scheme.....	35
8.3.1.6.1	Beam management and CSI acquisition.....	35
8.3.1.6.2	MIMO schemes.....	35
8.3.1.6.3	Reference signal related to multi-antenna scheme.....	36
8.3.1.6.3.1	SRS.....	36
8.3.1.6.3.2	PT-RS.....	37
8.3.2	Physical channel procedure.....	37
8.3.2.1	Random access procedure.....	37
8.3.2.1.1	Preamble.....	37
8.3.2.1.2	Procedure.....	38
8.3.2.2	Scheduling.....	38
8.3.2.3	Power control.....	39
8.3.2.4	HARQ.....	39
8.4	Duplexing.....	39
8.5	LTE-NR Co-existence.....	39
8.6	Carrier Aggregation / Dual Connectivity.....	40
9	Layer 2 and RRC for next generation radio.....	40
9.1	Overview of Layer 2 functions.....	40
9.2	MAC Sublayer.....	42
9.3	RLC Sublayer.....	42
9.4	PDCP Sublayer.....	42
9.5	New AS sublayer.....	43
9.6	Overview of Layer 2 data flow.....	43
9.7	Numerologies and TTI durations.....	43
9.8	RRC.....	44
9.8.1	Functions.....	44
9.8.2	UE states and state transitions.....	44
9.8.2.1	RAN-based notification are management.....	46
9.8.3	System information handling.....	46
9.8.3.1	Dual Connectivity between LTE and NR.....	47
9.8.4	Measurements.....	47
9.8.4.1	Dual Connectivity between LTE and NR.....	47
9.8.5	Access control.....	48
9.8.6	UE capability retrieval framework.....	48
10	Architecture for next generation RAN.....	48
10.1	RAN-CN functional split.....	48
10.2	Overall architecture.....	49
10.3	Interfaces.....	50
10.3.1	RAN-CN interface.....	50
10.3.1.1	General principles.....	50
10.3.1.2	NG Interface Functions.....	50
10.3.1.3	NG Interface Architecture.....	51
10.3.1.4	NG Control Plane.....	51
10.3.1.5	NG User Plane.....	51
10.3.2	RAN internal interface.....	52
10.3.2.1	Xn Interface.....	52
10.3.2.1.1	General principles.....	52
10.3.2.1.2	Xn Interface Functions.....	52

10.3.2.1.3	Xn Control Plane .....	53
10.3.2.1.4	Xn User Plane.....	53
11	QoS.....	54
11.1	QoS architecture in NR and NextGen Core.....	54
11.2	Dual Connectivity between LTE and NR via EPC.....	56
12	Support for Network Slicing .....	56
13	Key higher layer and network procedures.....	56
13.1	Initial access .....	56
13.1.1	Cell selection .....	56
13.1.2	Random access procedure.....	57
13.2	Mobility.....	57
13.2.1	Intra-RAT .....	57
13.2.1.1	UE based mobility .....	57
13.2.1.1.1	Cell reselection .....	57
13.2.1.1.2	Paging.....	58
13.2.1.2	Network controlled mobility .....	58
13.2.2	Inter-RAT .....	59
13.2.3	Mobility related to Dual Connectivity between LTE and NR .....	61
13.3	Dual Connectivity between NR and LTE.....	62
13.3.1	General.....	62
13.3.2	Option 3/3a/3x .....	62
13.3.2.1	General principles for Xx interface .....	62
13.3.2.2	Architectural aspects .....	62
13.3.2.3	Procedural aspects .....	63
13.3.3	Option 4/4a .....	63
13.3.3.1	Architectural aspects .....	63
13.3.3.2	Procedural aspects .....	64
13.3.4	Option 7/7a/7x .....	64
13.3.4.1	Architectural aspects .....	64
13.3.4.2	Procedural aspects .....	65
13.4	PDU Session Management .....	65
13.4.1	Session Setup .....	65
13.4.2	Session Modification .....	66
13.4.3	Session Release.....	66
14	Radio transmission/reception .....	67
14.1	Potential spectrum .....	67
14.2	Co-existence consideration.....	68
14.3	UE/BS RF feasibility .....	68
14.3.1	Common requirements for UE and BS .....	68
14.3.1.1	Subcarrier spacing.....	69
14.3.1.2	Maximum channel bandwidth.....	69
14.3.1.3	Flexible channel bandwidth .....	69
14.3.1.4	UE transmission bandwidth configuration adaptation .....	69
14.3.1.5	Spectrum Utilization .....	70
14.3.2	UE RF requirements .....	70
14.3.2.1	Wide frequency range of up to 52.6 GHz handling.....	70
14.3.2.2	Stand-Alone and Non-Stand-Alone perspective .....	70
14.3.2.3	Multiple numerologies within one carrier .....	71
14.3.3	BS RF requirements.....	71
14.3.3.1	Wide frequency range of up to 52.6 GHz handling.....	71
14.3.3.2	Multiple numerologies within one carrier .....	72
14.3.3.3	Beam related NR BS specific requirement.....	72
15	Conclusions .....	72
<b>Annex A:</b>	<b>SI description for Study on New Radio (NR) Access Technology .....</b>	<b>73</b>
	Justification .....	73
	Objective of SI .....	73
	Impacts .....	75

**Annex B: Change history** .....75  
History .....76

**iTeh STANDARD PREVIEW**  
**(standards.iteh.ai)**  
Full standard:  
<https://standards.iteh.ai/catalog/standards/sist/e8ffde6d-d8b1-4a6b-8347-1bfde3163573/etsi-tr-138-912-v14.0.0-2017-05>

---

# Foreword

This Technical Specification has been produced by the 3rd Generation Partnership Project (3GPP).

The contents of the present document are subject to continuing work within the TSG and may change following formal TSG approval. Should the TSG modify the contents of the present document, it will be re-released by the TSG with an identifying change of release date and an increase in version number as follows:

Version x.y.z

where:

- x the first digit:
  - 1 presented to TSG for information;
  - 2 presented to TSG for approval;
  - 3 or greater indicates TSG approved document under change control.
- y the second digit is incremented for all changes of substance, i.e. technical enhancements, corrections, updates, etc.
- z the third digit is incremented when editorial only changes have been incorporated in the document.

**iTeh STANDARD PREVIEW**  
(standards.iteh.ai)  
Full standard:  
<https://standards.iteh.ai/catalog/standards/sist/e8ffde6d-d8b1-4a6b-8347-1bfde3163573/etsi-tr-138-912-v14.0.0-2017-05>



---

# 1 Scope

This document is intended to gather all technical outcome of the study item "Next Generation New Radio (NR) Access Technology" (see Annex A).

This activity involves the Radio Access work area of the 3GPP studies and has impacts both on the Mobile Equipment and Access Network of the 3GPP systems.

---

# 2 References

The following documents contain provisions which, through reference in this text, constitute provisions of the present document.

- References are either specific (identified by date of publication, edition number, version number, etc.) or non-specific.
- For a specific reference, subsequent revisions do not apply.
- For a non-specific reference, the latest version applies. In the case of a reference to a 3GPP document (including a GSM document), a non-specific reference implicitly refers to the latest version of that document *in the same Release as the present document*.

- [1] 3GPP TR 21.905: "Vocabulary for 3GPP Specifications".
- [2] Void.
- [3] Void.
- [4] Void.
- [5] Void.
- [6] Void.
- [7] 3GPP TS 36.304: "Evolved Universal Terrestrial Radio Access (E-UTRA); User Equipment (UE) procedures in idle mode".
- [8] 3GPP TS 36.331: "Evolved Universal Terrestrial Radio Access (E-UTRA); Radio Resource Control (RRC); Protocol specification".
- [9] 3GPP TR 38.913: "Study on Scenarios and Requirements for Next Generation Access Technologies".
- [10] 3GPP TS 36.401: "Evolved Universal Terrestrial Radio Access Network (E-UTRAN); Architecture description".
- [11] Void.
- [12] 3GPP TS 36.300: "Evolved Universal Terrestrial Radio Access (E-UTRA) and Evolved Universal Terrestrial Radio Access Network (E-UTRAN); Overall description; Stage 2".
- [13] 3GPP TS 36.423: "Evolved Universal Terrestrial Radio Access Network (E-UTRAN); X2 application protocol (X2AP)".

## 3 Definitions, symbols and abbreviations

### 3.1 Definitions

For the purposes of the present document, the terms and definitions given in 3GPP TR 21.905 [1] and the following apply. A term defined in the present document takes precedence over the definition of the same term, if any, in 3GPP TR 21.905 [1].

**example:** text used to clarify abstract rules by applying them literally.

**Multi-Connectivity:** Mode of operation whereby a multiple Rx/Tx UE in the connected mode is configured to utilise radio resources amongst E-UTRA and/or NR provided by multiple distinct schedulers connected via non-ideal backhaul.

**NextGen Core:** (=NGC) Core Network for Next Generation System.

**NG:** The interface between a gNB and a NextGen Core.

**NR-PSS/SSS:** Primary and Secondary synchronisation signal for NR.

**Transmission Reception Point:** Antenna array with one or more antenna elements available to the network located at a specific geographical location for a specific area.

### 3.2 Symbols

For the purposes of the present document, the following symbols apply:

$K_{\text{eNB}}$	eNB key
$L_{\text{TB,CRC}}$	Number of bits for TB-level CRC (Cyclic Redundancy Check) before code block segmentation
$S\text{-}K_{\text{eNB}}$	SeNB key
$T_s$	Basic time unit

### 3.3 Abbreviations

For the purposes of the present document, the abbreviations given in 3GPP TR 21.905 [1] and the following apply. An abbreviation defined in the present document takes precedence over the definition of the same abbreviation, if any, in 3GPP TR 21.905 [1].

AAS	Active Antenna array System
CB	Code Block
CBG	Code Block Group
CBW	Channel BandWidth
CC	Chase Combining, Component Carrier
CCE	Control Channel Element
CP	Cyclic Prefix, Control Plane
CSI-RS	Channel State Information
DC	Dual Connectivity
DCI	Downlink Control Information
DM-RS	DeModulation-Reference Signal
eIMTA	Enhanced Interference Management and Traffic Adaptation
EIRP	Equivalent Isotropically Radiated Power
eMBB	Enhanced Mobile BroadBand
eV2X	Enhanced Vehicule to Everything
gNB	gNode B (supporting NR and connectivity to NGC)
GT	Guard Time
IMR	Interference Measurement Resource
IR	Incremental Redundancy
LBRM	Limited Buffer Rate Matching
LDPC	Low-Density Parity-Check
MCG	Master Cell Group

MCL	Minimum Coupling Loss
MCS	Modulation Coding Scheme
MIB	Master Information Block
MU-MIMO	Multi-User Multiple Input Multiple Output
mMTC	Massive Machine Type Communication
NGC	Next Generation Core Network
NG-U	NG for the user plane
NR	New Radio
NR-PSS	New Radio-Primary Synchronization Signal
NR-SSS	New Radio-Secondary Synchronization Signal
NZP	Non Zero Power
OTA	Over The Air
PMI	Precoding Matrix Indicator
PSCell	Primary SCell
PT-RS	Phase Tracking Reference Signal
QCL	Quasi-colocation
QC-LDPC	Quasi-Cyclic Low Density Parity Check
RAR	Random Access Response
RE	Resource Element
REG	Resource Element Group
SAR	Specific Absorption Rate
SCG	Secondary Cell Group
SeNB	Secondary eNB
SRI	SRS Resource Indicator
SRS	Sounding Reference Signal
TB	Transport Block
TRI	Transmit Rank Indicator
TRxP	Transmission Reception Point
UCI	Uplink Control Information
UPGW	User Plane Gateway
URLLC	Ultra-Reliable and Low Latency Communications

---

## 4 Introduction

At the 3GPP TSG RAN #71 meeting, the Study Item description on " New SID Proposal: Study on New Radio Access Technology " was approved (see Annex A). The study item covers technology components to be considered for new radio access technologies, e.g. to fulfil the requirements on IMT-2020. This technical report covers all RAN aspects of these technology components.

---

## 5 Deployment scenario

A very large set of deployment scenarios (deployment scenarios for eMBB, mMTC, URLLC, eV2X) are foreseen, as described in 38.913 [9] section 6.1:

In order to enable the large number of possibilities, the RAN architecture will support the following:

- Non-centralised deployment: In this scenario, the full NR protocol stack is supported at the gNB e.g. in a macro deployment or indoor hotspot environment (could be public or enterprise).
- Centralized deployment: In this scenario, the upper layers of the NR radio stacks are centralized at the Central Unit. Different protocol split options between Central Unit and lower layers of gNB nodes may be possible. The functional split between the Central Unit and lower layers of gNB nodes may depend on the transport layer. High performance transport between the Central Unit and lower layers of gNB nodes, e.g. optical networks, can enable advanced CoMP schemes and scheduling optimization, which could be useful in high capacity scenarios, or scenarios where cross cell coordination is beneficial. Low performance transport between the Central Unit and lower layers of gNB nodes can enable the higher protocol layers of the NR radio stacks to be supported in the Central Unit, since the higher protocol layers have lower performance requirements on the transport layer in terms of bandwidth, delay, synchronization and jitter.

- Co-sited deployment with E-UTRA: In this scenario the NR functionality is co-sited with E-UTRA functionality either as part of the same base station or as multiple base stations at the same site. Co-sited deployment can be applicable in all NR deployment scenarios e.g. Urban Macro. In this scenario it is desirable to fully utilise all spectrum resources assigned to both RATs by means of load balancing or connectivity via multiple RATs (e.g. utilising lower frequencies as coverage layer for users on cell edge).
- Shared RAN deployment: NR should support shared RAN deployments, supporting multiple hosted Core Operators. The Shared RAN could cover large geographical areas, as in the case of national or regional network sharing. The Shared RAN coverage could also be heterogeneous, i.e. limited to few or many smaller areas, for example in the case of Shared in-building RANs. A shared RAN should be able to efficiently interoperate with a non-shared RAN. Each Core Operator may have their own non-shared RAN serving areas adjacent to the Shared RAN. Mobility between the non-shared RAN and the Shared RAN shall be supported in a way at least as good as for LTE. The Shared RAN may (as for the case of LTE) operate either on shared spectrum or on the spectrum of each hosted Operator.

The RAN architecture will support following scenarios for connectivity between RAN consisting of E-UTRA and NR, and a CN consisting of an NGC and an EPC. The connectivity scenario in figure 5-1 includes support for deployment with LTE eNB connected to the EPC with Non-standalone NR. The connectivity scenario in figure 5-2 includes support for deployment with gNB connected to the NGC either as standalone or with Non-standalone E-UTRA, and deployment with LTE eNB connected to the NGC either as standalone or with Non-standalone NR.

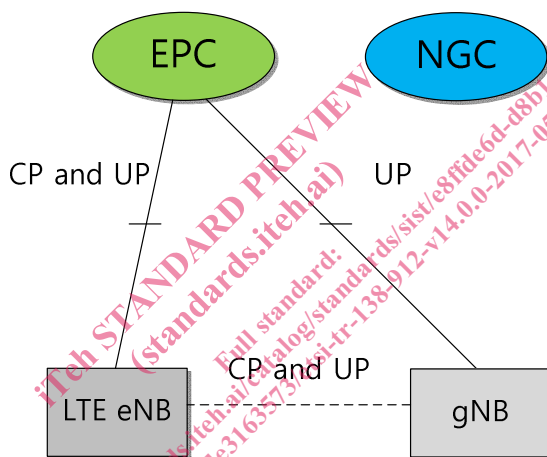

Figure 5-1: E-UTRA and NR connected to the EPC

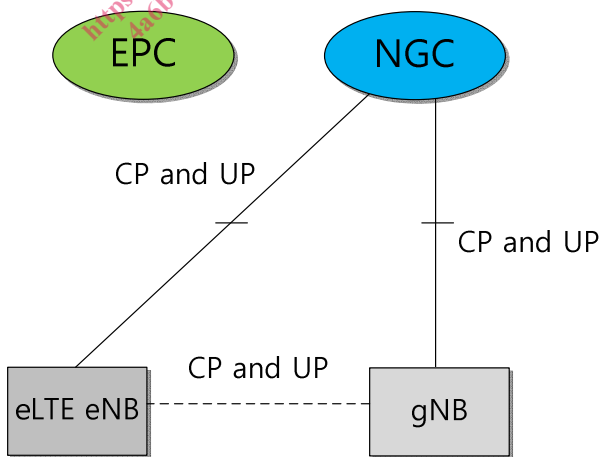

Figure 5-2: E-UTRA and NR connected to the NGC

## 6 Forward compatibility

Forward compatibility of NR shall ensure smooth introduction of future services and features while efficient access of the earlier services and UEs in the same spectrum is still ensured.

In order to ensure forward compatibility of NR, explicit signaling to NR UEs can indicate reserved resources. At least some reserved resources are indicated by using at least RRC signaling.

For RAN3 RAN internal interfaces and the RAN-CN interface, forwards compatibility of the protocol is assured by extension mechanisms such as those described in chapter 10 of 25- and 36-series application protocol specifications on message and IE level whenever existing messages are reused.

## 7 Radio interface protocol architecture for next generation radio

To support tight interworking between LTE and NR, a technology of aggregating data flows between the two RATs is studied based on Dual Connectivity (DC) for LTE [12]. In DC between LTE and NR, both (e)LTE eNB and NR gNB can act as a master node as described in sub-clause 4.1.2.1, 4.1.2.2 and 4.1.2.3. It is assumed that DC between LTE and NR supports the deployment scenario where LTE eNB is not synchronised with NR gNB.

For NR, a technology of aggregating NR carriers is studied. Both lower layer aggregation like Carrier Aggregation (CA) for LTE (see [12]) and upper layer aggregation like DC are investigated. From layer 2/3 point of view, aggregation of carriers with different numerologies is supported in NR. Radio interface protocols for NR are designed flexibly to allow the possibility of intra-frequency DC and Multi-Connectivity.

In this sub-clause, the radio interface protocol architecture of NR is described for the user plane and the control plane encompassing DC between LTE and NR, and lower/higher layer aggregation of NR carriers.

### 7.1 User plane

#### 7.1.1 User plane protocol stack for NR

The figure below shows the protocol stack for the user plane, where PDCP, RLC and MAC sublayers (terminated in gNB on the network side) perform the functions listed for the user plane in sub-clause 9.2, 9.3 and 9.4, respectively. In addition, a new AS sublayer is introduced above PDCP as described in sub-clause 9.5.

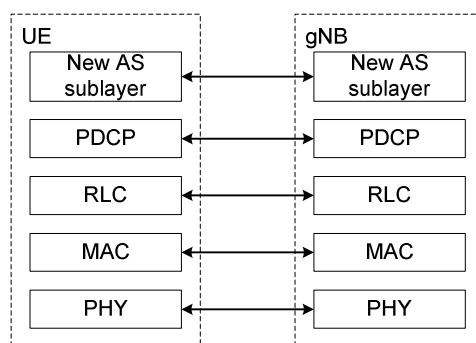

**Figure 7.1.1-1: User plane protocol stack**

NOTE: Terminology of each layer 2 sublayer could be changed in the normative phase.

#### 7.1.2 Bearer types for Dual Connectivity between LTE and NR

The following three types of bearer are supported for Dual Connectivity between LTE and NR regardless of the connected CN, except for the split bearer via SCG where the master node is gNB (i.e. NR):