

---

---

**Paper and board — Determination of  
bending resistance —**

**Part 2:  
Taber-type tester**

*Papier et carton — Détermination de la résistance à la flexion —*

*Partie 2: Rigidimètre Taber*

**iTeh STANDARD PREVIEW**  
**(standards.iteh.ai)**

ISO 2493-2:2011

<https://standards.iteh.ai/catalog/standards/sist/917b89e0-a817-442f-9fc6-b26d6bc0cca4/iso-2493-2-2011>



## iTeh STANDARD PREVIEW (standards.iteh.ai)

ISO 2493-2:2011

<https://standards.iteh.ai/catalog/standards/sist/917b89e0-a817-442f-9fc6-b26d6bc0cca4/iso-2493-2-2011>



### **COPYRIGHT PROTECTED DOCUMENT**

© ISO 2011

All rights reserved. Unless otherwise specified, no part of this publication may be reproduced or utilized in any form or by any means, electronic or mechanical, including photocopying and microfilm, without permission in writing from either ISO at the address below or ISO's member body in the country of the requester.

ISO copyright office  
Case postale 56 • CH-1211 Geneva 20  
Tel. + 41 22 749 01 11  
Fax + 41 22 749 09 47  
E-mail [copyright@iso.org](mailto:copyright@iso.org)  
Web [www.iso.org](http://www.iso.org)

Published in Switzerland

## Foreword

ISO (the International Organization for Standardization) is a worldwide federation of national standards bodies (ISO member bodies). The work of preparing International Standards is normally carried out through ISO technical committees. Each member body interested in a subject for which a technical committee has been established has the right to be represented on that committee. International organizations, governmental and non-governmental, in liaison with ISO, also take part in the work. ISO collaborates closely with the International Electrotechnical Commission (IEC) on all matters of electrotechnical standardization.

International Standards are drafted in accordance with the rules given in the ISO/IEC Directives, Part 2.

The main task of technical committees is to prepare International Standards. Draft International Standards adopted by the technical committees are circulated to the member bodies for voting. Publication as an International Standard requires approval by at least 75 % of the member bodies casting a vote.

Attention is drawn to the possibility that some of the elements of this document may be the subject of patent rights. ISO shall not be held responsible for identifying any or all such patent rights.

ISO 2493-2 was prepared by Technical Committee ISO/TC 6, *Paper, board and pulps*, Subcommittee SC 2, *Test methods and quality specifications for paper and board*.

This first edition, together with ISO 2493-1, cancels and replaces ISO 2493:1992, which has been technically revised. In the revision, ISO 2493:1992 was divided into two parts due to different measuring principles. ISO 2493-1 describes the constant rate of deflexion and this part of ISO 2493 describes the Taber-type tester. ISO 2493-1 also gives the possibility to use a smaller bending length and a lower bending angle if needed. Optional calculation in index form has been added. A precision statement has been added in informative Annex A.

(standards.iteh.ai)

ISO 2493 consists of the following parts, under the general title *Paper and board — Determination of bending resistance*:

[ISO 2493-2:2011](https://standards.iteh.ai/catalog/standards/sist/917b89e0-a817-442f-9fc6-626d6bc0cca4/iso-2493-2-2011)

- *Part 1: Constant rate of deflection*
- *Part 2: Taber-type tester*

## Introduction

In ISO 2493:1992, two principles for determining the bending resistance were incorporated in the same standard although the two principles are very different.

One principle involved the deflection of an equal number of test pieces with opposing surfaces towards the direction of deflection; this principle is described in ISO 2493-1.

The other principle used a Taber-type tester, where the test piece is inserted and deflected to the top side and then, without changing the test piece, it is deflected in the opposite direction. This principle is described in this part of ISO 2493. The method is based on TAPPI Test Method T 489 om-08 <sup>[4]</sup>.

## iTeh STANDARD PREVIEW (standards.iteh.ai)

[ISO 2493-2:2011](https://standards.iteh.ai/catalog/standards/sist/917b89e0-a817-442f-9fc6-b26d6bc0cca4/iso-2493-2-2011)

<https://standards.iteh.ai/catalog/standards/sist/917b89e0-a817-442f-9fc6-b26d6bc0cca4/iso-2493-2-2011>

# Paper and board — Determination of bending resistance —

## Part 2: Taber-type tester

### 1 Scope

This part of ISO 2493 specifies procedures to measure the bending resistance of paper and paperboard.

This part of ISO 2493 is used to determine the bending moment required to deflect the free end of a 38 mm wide vertically clamped specimen by 15° when the load is applied at a bending length of 50 mm. For boards that tend to be permanently deformed if bent through 15°, the half bending angle, i.e. 7,5°, can be used. The bending resistance is expressed in terms of the bending moment and parameters set by the manufacturer of the Taber-type tester.

The method is primarily used for papers with a high grammage.

NOTE This part of ISO 2493 does not cover the low-range version of the Taber-type instrument that uses a bending length of 10 mm (Reference [5]).

iteh STANDARD PREVIEW

### 2 Normative references (standards.iteh.ai)

The following referenced documents are indispensable for the application of this document. For dated references, only the edition cited applies. For undated references, the latest edition of the referenced document (including any amendments) applies.

ISO 186, *Paper and board — Sampling to determine average quality*

ISO 187, *Paper, board and pulps — Standard atmosphere for conditioning and testing and procedure for monitoring the atmosphere and conditioning of samples*

### 3 Terms and definitions

For the purposes of this document, the following terms and definitions apply.

#### 3.1

##### bending moment

*M*

moment required to bend a rectangular test piece clamped at one end, the moment being measured under the conditions specified in this part of ISO 2493

NOTE Bending moment is expressed in millinewton metres (mN·m).

#### 3.2

##### bending resistance

*B*

mean bending moment required to bend a rectangular test piece fastened at one end in a clamp, the bending moment being measured under the conditions specified in this part of ISO 2493

NOTE Bending resistance is expressed in millinewton metres (mN·m).

**3.3**  
**bending angle**

$\alpha$   
angle through which the clamp rotates while moving from its initial position to the position at which the bending resistance is measured

NOTE The bending angle is 15° or 7,5° (see Clause 10).

**3.4**  
**bending length**

constant radial distance between the clamp and the position on the test piece at which the force is applied

**3.5**  
**bending resistance index**

bending resistance divided by the grammage to the third power

**4 Principle**

A test piece of defined dimensions is bent through a specified bending angle (3.3) using a specific type of testing instrument. The resulting bending moment is read from the instrument scale.

**5 Apparatus**

**5.1 Bending resistance tester** (see Figure 1), consisting of the following components.

**5.1.1 Pendulum, P**, rotating around a centre-point, CP, on low-friction bearings, carrying a clamp, C, that has two screws for holding and centring the test piece, TP. At the high end, a centre-line, L, is engraved that coincides with the centre of the test piece. At the lower end of the pendulum is a stud, S1, to which weights may be attached and that loads the pendulum at a distance of 100,0 mm  $\pm$  0,1 mm from the centre-point. Without added weights, the loading is 10,000 g  $\pm$  0,001 g.

**5.1.2 Vertical disc, VD**, rotating around the centre-point, CP, and driven by a motor, carries two driving arm attachments, DAA, so located as to provide the test piece, TP, with a cantilevered loading length via two driving arms, DA. The bending length (3.4) is 50,0 mm  $\pm$  0,1 mm. The driving arms are adjustable by means of screws which enables testing of test pieces of different thicknesses. The ends of the driving arms have rollers as means of transmitting the force to the test piece. It is possible to adjust the length of the arms so that the distance between the test piece and each roller is 0,33 mm  $\pm$  0,03 mm.

On the edge of the upper part of the disc, a centre-line mark is engraved. Two reference lines are engraved on the periphery of the vertical disc, VD, at an angular distance of 7,5° and 15° on both sides of the centre-line mark.

A driving mechanism drives the vertical disc, VD, at a nominal constant rate which is allowed to vary between 170° and 210° per minute.

**5.1.3 Fixed annular disc, FAD**, located around the periphery of the vertical disc, VD. The fixed annular disc has a scale from 0 to 100 on both sides of a centre-line mark, zero. The scale shows the bending moment required to bend the test piece to the right or to the left. (For clarity, only the scale marks 0, 20 and 40 are shown in Figure 1.)

**5.1.4 Stand**, to support the pendulum, P, the vertical disc, VD, and the fixed annular disc, FAD, equipped with a means for levelling the instrument.

**5.1.5 Various loading weights**, in stiffness units defined by the manufacturer to be mounted on the stud, S1, to give a maximum bending moment of 490 mN·m.

## 5.2 Preparation of apparatus

Place the instrument on a firm, flat surface. Set the vertical disc, VD, at zero and place a chosen weight, W, on the stud, S1. Close the clamp, C, so that the faces meet on the centre-line of the pendulum. Level the instrument so that the pendulum is vertical.

Displace the pendulum by 15° and release it to check the bearing friction. It should make at least 20 complete swings before coming to rest.

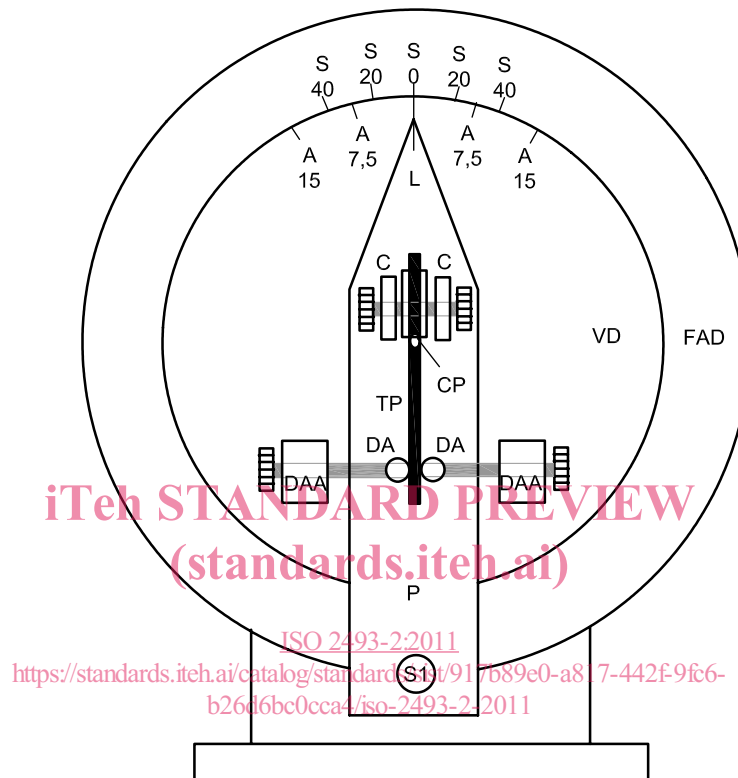

### Key

VD	vertical disc	DAA	driving arm attachments
P	pendulum	DA	driving arms
TP	test piece	FAD	fixed annular disc
C	clamp	S 0	reference line stiffness 0
CP	centre-point	S 20	reference line stiffness 20
S1	stud	S 40	reference line stiffness 40
A 7,5	reference line, 7,5° deflection	L	centre-line of the pendulum
A 15	reference line, 15° deflection		

Figure 1 — Taber-type tester

## 6 Calibration

Calibrate the instrument and check the accuracy of the apparatus at regular intervals. The method of calibration depends on the type of instrument and shall be done by following the manufacturer's instructions.

NOTE Spring-steel test pieces are commonly supplied by the manufacturer of the instrument for calibration purposes.

## 7 Sampling

If the tests are being made to evaluate a lot, the sample shall be selected in accordance with ISO 186. If the tests are made on another type of sample, make sure that the test pieces taken are representative of the samples received.

## 8 Conditioning

Condition the samples of paper or board as specified in ISO 187. Keep them in the conditioning atmosphere throughout the test procedure.

## 9 Preparation of test pieces

Carry out the preparation of test pieces and the testing in the same conditioning atmosphere as that used to condition the samples.

If the bending resistance index (3.5) is required, determine the grammage in accordance with ISO 536 [1].

As required, cut a sufficient number of test pieces,  $38,0 \text{ mm} \pm 0,2 \text{ mm}$  wide by  $70 \text{ mm} \pm 1 \text{ mm}$  long, with the length parallel to the machine direction, to enable 5 valid tests to be performed in this direction; and/or cut another set of test pieces with the length parallel to the cross-direction to enable 5 valid tests to be performed in this direction.

Avoid folds, creases, visible cracks or other defects in the area to be tested. If watermarks are present, this shall be noted in the test report.

Highly twisted and curled test pieces may give unreliable results. It is not possible to straighten curled or twisted samples without damaging the material.

## 10 Procedure

ISO 2493-2:2011  
<https://standards.iteh.ai/catalog/standards/sist/917b89e0-a817-442f-9fc6-b26d6bc0cca4/iso-2493-2-2011>

Place a test piece in the clamp, C, with one end approximately level with its top edge and the other end between the rollers at the end of the driving arms, DA.

With the two clamping screws of the clamp, C, align the test piece with the centre-line, L, of the pendulum.

The pressure of the clamping screws may affect the test results. It should be firm enough to hold the test piece, but not so firm as to compress or deform it. The test piece should not be restrained at the free end except by the friction imposed on the surfaces of the free end of the test piece by the driving arms, DA.

Adjust the rollers at the end of the driving arms, DA, so that they are just in contact with the test piece. Adjust the length of one of the driving arms, DA, so that the distance between the test piece and the roller is  $0,33 \text{ mm} \pm 0,03 \text{ mm}$ .

NOTE 1 It is not necessary for the pendulum to balance at zero with the undeflected test piece in place. Curvature of the test piece will result in a difference between the readings for deflection in the two directions. Readings taken in the two directions are averaged to give the stiffness of the test piece.

Switch on the motor to rotate the vertical disc, VD, to the left and thus deflect the test piece until the centre-line mark, L, on the pendulum is aligned with the  $15^\circ$  mark on the vertical disc VD.

Record the scale reading on the fixed annular disc, FAD, and immediately return the loading disc to zero. Take a similar reading by deflecting the test piece to the right. As required, test at least five machine direction (MD) test pieces and/or at least five cross-direction (CD) test pieces to obtain five valid results, i.e. ten valid readings, for each required direction.

If the maximum force is obtained before the test piece has been bent through the bending angle  $15^\circ$  (3.3), or a break, kink or crease is observed, the test result should be discarded. If more than 10 % of the test pieces cut in a particular direction of interest (machine direction or cross-direction) exhibit this behaviour, use a bending angle of  $7,5^\circ$  for this test piece direction. If so, the bending angle shall be reported.



**IMPORTANT — The result obtained at a 7,5° bending angle cannot be converted to that of a 15° bending angle by multiplying by two, since the relationship is not directly proportional to the bending angle.**

NOTE 2 The tendency for the paper to be deformed in an unacceptable way increases with increasing thickness. The exact thickness for using the bending angle 7,5° cannot be stated.

## 11 Calculation

### 11.1 Bending moment

Calculate the bending moment (3.1),  $M$ , following the procedure in the manufacturer's manual for the compensating weight used.

For each desired direction, machine direction (MD) and/or cross-direction (CD), determine the bending resistance (3.2),  $B$ , as the mean bending moment, from all ten readings (five bending movements to the left, and five bending movements to the right).

Report the bending resistance (3.2), in millinewton metres in the machine direction and/or in the cross-direction, to three significant figures.

NOTE The instruments available report the result in Taber units. A conversion from Taber units to SI units can be achieved by using Equation (1) (Reference [4]):

$$M = T_r \times 0,098\ 066 \quad (1)$$

where

$M$  is the bending moment, in millinewton metres;

$T_r$  is the Taber bending-moment reading, in Taber units.

### 11.2 Bending resistance index

If required, calculate the bending resistance index (3.5),  $B_g$  for each required principal direction as follows:

$$B_g = \frac{B}{g^3} \quad (2)$$

where

$B_g$  is the bending resistance index, in millinewton metres times metres to the power six per gram cubed ( $\text{mNm} \cdot \text{m}^6/\text{g}^3$ );

$B$  is the bending resistance, in millinewton metres ( $\text{mN} \cdot \text{m}$ );

$g$  is the grammage, in grams per square metre ( $\text{g}/\text{m}^2$ ) determined in accordance with ISO 536 [1].

Report the bending resistance index for each required principal direction to three significant figures.

NOTE The bending resistance index is strictly applicable for test pieces of homogeneous materials, bent through small angles. The bending resistance index is nevertheless useful for a comparison of the bending resistance of papers with small differences in grammage or normalizing the bending resistance to a given grammage. Bending to an angle of 15° usually means there is a higher degree of plastic deformation of the test piece, the higher the grammage. For this reason, the bending resistance index is less useful for higher grammage material and less useful when papers with large differences in grammage are compared Reference [7].

## 12 Test report

The test report shall include the following information:

- a) a reference to this part of ISO 2493, i.e. ISO 2493-2:2011;