

---

---

**Paper and board — Determination of  
air permeance (medium range) —**

**Part 3:  
Bendtsen method**

*Papier et carton — Détermination de la perméabilité à l'air (plage de  
valeurs moyennes) —*

**iTeh STANDARD PREVIEW**  
*Partie 3: Méthode Bendtsen*  
**(standards.iteh.ai)**

ISO 5636-3:2013

[https://standards.iteh.ai/catalog/standards/sist/1e709b51-2ac9-4956-a591-  
ed05828e75e8/iso-5636-3-2013](https://standards.iteh.ai/catalog/standards/sist/1e709b51-2ac9-4956-a591-ed05828e75e8/iso-5636-3-2013)



**iTeh STANDARD PREVIEW**  
**(standards.iteh.ai)**

ISO 5636-3:2013

<https://standards.iteh.ai/catalog/standards/sist/1e709b51-2ac9-4956-a591-ed05828e75e8/iso-5636-3-2013>



**COPYRIGHT PROTECTED DOCUMENT**

© ISO 2013

All rights reserved. Unless otherwise specified, no part of this publication may be reproduced or utilized otherwise in any form or by any means, electronic or mechanical, including photocopying, or posting on the internet or an intranet, without prior written permission. Permission can be requested from either ISO at the address below or ISO's member body in the country of the requester.

ISO copyright office  
Case postale 56 • CH-1211 Geneva 20  
Tel. + 41 22 749 01 11  
Fax + 41 22 749 09 47  
E-mail [copyright@iso.org](mailto:copyright@iso.org)  
Web [www.iso.org](http://www.iso.org)

Published in Switzerland

# Contents

	Page
Foreword .....	iv
<b>1 Scope</b> .....	<b>1</b>
<b>2 Normative references</b> .....	<b>1</b>
<b>3 Terms and definitions</b> .....	<b>1</b>
<b>4 Principle</b> .....	<b>1</b>
<b>5 Apparatus</b> .....	<b>2</b>
<b>6 Sampling</b> .....	<b>3</b>
<b>7 Conditioning</b> .....	<b>3</b>
<b>8 Preparation of test pieces</b> .....	<b>3</b>
<b>9 Calibration</b> .....	<b>3</b>
9.1 Variable-area flow-measuring device .....	3
9.2 Electronic flow-measuring device .....	3
<b>10 Procedure</b> .....	<b>3</b>
<b>11 Calculation and expression of results</b> .....	<b>4</b>
11.1 Calculation of air permeance .....	4
11.2 Reporting the results .....	4
11.3 Standard deviation and coefficient of variation .....	4
<b>12 Test report</b> .....	<b>4</b>
<b>Annex A (normative) Calibration of capillary tubes and variable-area flowmeters</b> .....	<b>6</b>
<b>Annex B (normative) Care and maintenance of variable-area flowmeter-type Bendtsen testers</b> .....	<b>10</b>
<b>Annex C (informative) Precision</b> .....	<b>12</b>
<b>Bibliography</b> .....	<b>14</b>

## Foreword

ISO (the International Organization for Standardization) is a worldwide federation of national standards bodies (ISO member bodies). The work of preparing International Standards is normally carried out through ISO technical committees. Each member body interested in a subject for which a technical committee has been established has the right to be represented on that committee. International organizations, governmental and non-governmental, in liaison with ISO, also take part in the work. ISO collaborates closely with the International Electrotechnical Commission (IEC) on all matters of electrotechnical standardization.

The procedures used to develop this document and those intended for its further maintenance are described in the ISO/IEC Directives, Part 1. In particular the different approval criteria needed for the different types of ISO documents should be noted. This document was drafted in accordance with the editorial rules of the ISO/IEC Directives, Part 2 (see [www.iso.org/directives](http://www.iso.org/directives)).

Attention is drawn to the possibility that some of the elements of this document may be the subject of patent rights. ISO shall not be held responsible for identifying any or all such patent rights. Details of any patent rights identified during the development of the document will be in the Introduction and/or on the ISO list of patent declarations received (see [www.iso.org/patents](http://www.iso.org/patents)).

Any trade name used in this document is information given for the convenience of users and does not constitute an endorsement.

For an explanation on the meaning of ISO specific terms and expressions related to conformity assessment, as well as information about ISO's adherence to the WTO principles in the Technical Barriers to Trade (TBT) see the following URL: Foreword - Supplementary information

The committee responsible for this document is ISO/TC 6, *Paper, board and pulps*, Subcommittee SC 2, *Test methods and quality specifications for paper and board*.

This third edition cancels and replaces the second edition (ISO 5636-3:1992), which has been technically revised. In this third edition mainly editorial changes have been made and also precision data has been added as informative [Annex C](#).

ISO 5636 consists of the following parts, under the general title *Paper and board — Determination of air permeance (medium range)*:

- *Part 3: Bendtsen method*
- *Part 4: Sheffield method*
- *Part 5: Gurley method*
- *Part 6: Oken method*

NOTE 1 *Part 1: General method* will be withdrawn after the third editions of Parts 3, 4 and 5 have been published, as it was considered redundant.

NOTE 2 *Part 2: Schopper method* was withdrawn in 2006 as it was considered obsolete.

NOTE 3 *Part 6: Oken method* is being prepared.

# Paper and board — Determination of air permeance (medium range) —

## Part 3: Bendtsen method

### 1 Scope

This part of ISO 5636 specifies the Bendtsen method for determining the air permeance of paper and board using the Bendtsen apparatus.

It is applicable to papers and boards which have air permeances between  $0,35 \mu\text{m}/(\text{Pa}\cdot\text{s})$  and  $15 \mu\text{m}/(\text{Pa}\cdot\text{s})$  when tested with the Bendtsen apparatus.

It is unsuitable for rough-surfaced materials which cannot be securely clamped to avoid leakage.

### 2 Normative references

The following documents, in whole or in part, are normatively referenced in this document and are indispensable for its application. For dated references, only the edition cited applies. For undated references, the latest edition of the referenced document (including any amendments) applies.

ISO 186, *Paper and board — Sampling to determine average quality*

ISO 187, *Paper, board and pulps — Standard atmosphere for conditioning and testing and procedure for monitoring the atmosphere and conditioning of samples*

### 3 Terms and definitions

For the purposes of this document, the following terms and definitions apply.

#### 3.1

##### air permeance

mean air flow rate through unit area under unit pressure difference in unit time, under specified conditions

Note 1 to entry: Air permeance is expressed in micrometres per pascal second [ $1 \text{ ml}/(\text{m}^2\cdot\text{Pa}\cdot\text{s}) = 1 \mu\text{m}/(\text{Pa}\cdot\text{s})$ ].

Note 2 to entry: This property is called air permeance, and not air permeability, because it is reported as a sheet property and is not standardized with respect to thickness to give a material property per unit thickness.

### 4 Principle

A test piece is clamped between a circular gasket and an annular flat surface of known dimensions. The absolute air pressure on one side of the test area of the test piece is equivalent to atmospheric pressure and the difference in pressure between the two sides of the test piece is maintained at a small, substantially constant, value during the test. Determination of the flow of air through the test area in a specified time.

## 5 Apparatus

Bendtsen apparatus, see [Figure 1](#), consisting of a compressor (see [5.1](#)) and a pressure stabilizing reservoir (see [5.2](#)) to supply air, a flowmeter (see [5.4](#)) with a pressure controlling device (see [5.3](#)) and a measuring head (see [5.5](#)).

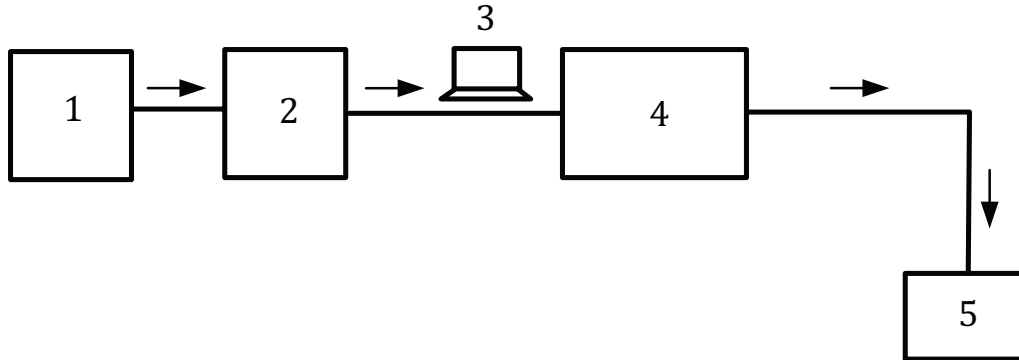

### Key

- 1 compressor
- 2 pressure stabilizing reservoir
- 3 pressure controlling device
- 4 flowmeter
- 5 sample clamping device and measuring head

iTech STANDARD PREVIEW  
(standards.itech.ai)

**Figure 1 — Flow diagram of the Bendtsen apparatus**

<https://standards.itech.ai/catalog/standards/sist/1e709b51-2ac9-4956-a591-ed05828e75e8/iso-5636-3-2013>

**5.1 Compressor**, generating air at a pressure of about 127 kPa. If necessary, filters shall be provided to ensure that the air is clean and free of oil.

**5.2 Pressure stabilizing reservoir**, having a vessel volume of about 10 litres and installed between the compressor and the pressure controlling device, or some other means of providing a stable air flow.

**NOTE** The pressure stabilizing reservoir is not normally supplied with the apparatus. Its provision, or some other means of providing a stable air flow, is the responsibility of the user.

**5.3 Pressure controlling device**, to control the air pressure at the inlet of the flowmeter. This shall comprise a manostat weight, a pressure regulator or some other means of creating a steady nominal air pressure of  $(1,47 \pm 0,02)$  kPa measured at the manostat.

**NOTE** Most Bendtsen apparatus are provided with three interchangeable manostat weights but only the 1,47 kPa manostat meets the requirement of this part of ISO 5636.

**5.4 Variable-area flowmeters**, to measure the flow rate in the following ranges: 5 ml/min to 150 ml/min, 50 ml/min to 500 ml/min and 300 ml/min to 3 000 ml/min. The resolution of these variable-area flowmeters shall be 2 ml/min, 5 ml/min and 20 ml/min respectively. The variable-area flowmeter may be replaced by an electronic air flowmeter having a measuring range suitable for the material measured that allows the air flow to be determined with an error of less than  $\pm 5$  ml/min or  $\pm 5$  % whichever is greater.

On some apparatus the available measuring ranges are 0 to 300 ml/min and 300 ml/min to 3 000 ml/min. The resolution of these variable area flowmeters shall be 1 % of the maximum reading scale.

**5.5 Measuring head**, consisting of a device in which the test piece is clamped between an annular flat surface and a circular rubber gasket. The annular ring and the gasket shall be of such dimensions that the

test area of the test piece enclosed by either of them is  $(1\ 000 \pm 20)$  mm<sup>2</sup>. The tubing used to connect the head to the flowmeter shall be made of rubber or plastics material,  $(7,0 \pm 0,5)$  mm in internal diameter and  $(690 \pm 10)$  mm long.

NOTE 1 A longer length of tubing results in a significant pressure drop between the flowmeter and the measuring head.

NOTE 2 On most commercial instruments the valve at the outlet of the flowmeter has two outlets. For air permeance measurement the tubing is connected to the larger diameter outlet.

**5.6 Flat non-porous plate**, of approximate dimensions 100 mm x 100 mm, which can be clamped between the rubber orifice plates to check the zero reading.

**5.7 Calibration plate device**, to enable the test assembly to be connected to an external calibration system (see [Clause 9](#) and [Annex A](#)).

## 6 Sampling

If the mean quality of a lot is to be determined, sampling shall be in accordance with ISO 186. If the tests are made on another type of sample, make sure that the test pieces taken are representative of the sample received.

## 7 Conditioning

Condition the sample in accordance with ISO 187.

## 8 Preparation of test pieces

Prepare the test pieces in the same atmospheric conditions as those used to condition the sample.

Cut not less than 10 test pieces and identify their two sides, for example side 1 and side 2. The test area shall be free from folds, wrinkles, holes, watermarks or defects not inherent to the sample. Do not handle the part of the test piece which will become part of the test area. An adequate test piece size is 100 mm x 100 mm.

If the air permeances measured on the two sides are significantly different and if this difference is required to be shown in the test report, 10 tests are required for each side.

## 9 Calibration

### 9.1 Variable-area flow-measuring device

Calibrate the variable-area flowmeter by temporarily replacing the measuring head with the appropriate calibrated capillary tube.

Calibrate the instrument sufficiently frequent to ensure that the reading does not deviate at any time by more than  $\pm 5\%$  from the true value.

### 9.2 Electronic flow-measuring device

Calibrate the instrument according to the instructions of the manufacturer.

## 10 Procedure

Carry out the test in the same atmospheric conditions used for the conditioning and preparation of test pieces.

Tests shall be performed according to the instructions of the manufacturer.

Test a minimum of 10 test pieces, five with side 1 up and five with side 1 down.

If applicable, choose a variable-area flowmeter which gives readings greater than 20 % of the scale range with 1,47 kPa. Air flows above 1 200 ml/min shall not be used because at high air flows the pressure drop between the flowmeter and the measuring head significantly reduces the pressure in the measuring head.

NOTE Readings on variable-area flowmeters are unreliable at the low end of the scale range.

Check that the air flow reading obtained with the non-porous plate (see 5.6) clamped in the measurement gap is zero.

Place a test piece in the measuring gap and record the variable-area flowmeter reading at least 5 s after clamping, in ml/min, with the reading accuracy indicated in 5.4. Repeat for the remaining test pieces.

All papers are hygroscopic to some degree, and readings should be taken at the initial stabilization point to avoid any possible effect of incoming air adding moisture to, or extracting moisture from, the test piece.

## 11 Calculation and expression of results

### 11.1 Calculation of air permeance

Calculate the air permeance,  $P$ , in micrometres per pascal second, to three significant figures, from Equation (1):

$$P = 0,011\ 3 \times q \quad (1)$$

where  $q$  is the mean air flow rate, in millilitres per minute, passing through the test area of 1 000 mm<sup>2</sup> at a related pressure of 1,47 kPa in the measuring head.

If required, calculate the mean air permeance for each side separately. If the means for the two sides are significantly different (more than 10 %), 10 tests are required for each side.

### 11.2 Reporting the results

Report the results with three significant figures.

If the air permeances measured on the two sides are significantly different (more than 10 %) and if this difference is required to be shown in the test report, report the means for the two sides separately. Otherwise, calculate the mean value of the measurements for the two sides.

### 11.3 Standard deviation and coefficient of variation

If the standard deviation or coefficient of variation is required, calculate it from the replicate rate of flow of air measurements and correct to micrometres per pascal second using Equation (1).

If the results for the two sides are reported separately, calculate the standard deviations or coefficients of variation for the two sides separately.

## 12 Test report

The test report shall include the following information:

- a) a reference to this part of ISO 5636;
- b) date and place of testing;



- c) all the information necessary for the complete identification of the sample;
- d) the conditioning atmosphere used;
- e) the number of test pieces tested, as specified in [Clause 10](#) and [11.1](#);
- f) the nominal air pressure used;
- g) if applicable, the flowmeter range used;
- h) the mean air permeance or permeances, as specified in [11.2](#);
- i) if required, the standard deviation or coefficient of variation or the values for each side, as specified in [11.3](#);
- j) any deviations from this part of ISO 5636 that may have affected the results.

**iTeh STANDARD PREVIEW**  
**(standards.iteh.ai)**

[ISO 5636-3:2013](#)

<https://standards.iteh.ai/catalog/standards/sist/1e709b51-2ac9-4956-a591-ed05828e75e8/iso-5636-3-2013>