



DRAFT INTERNATIONAL STANDARD ISO/DIS 8820-9

ISO/TC 22/SC 3

Secretariat: DIN

Voting begins on
2010-12-14

Voting terminates on
2011-05-14

INTERNATIONAL ORGANIZATION FOR STANDARDIZATION • МЕЖДУНАРОДНАЯ ОРГАНИЗАЦИЯ ПО СТАНДАРТИЗАЦИИ • ORGANISATION INTERNATIONALE DE NORMALISATION

Road vehicles — Fuse-links —

Part 9: Fuse-links with shortened tabs (Type D)

Véhicules routiers — Liaisons fusibles —

Partie 9: Liaisons fusibles à languettes raccourcies (Type D)

ICS 43.040.10

In accordance with the provisions of Council Resolution 15/1993 this document is circulated in the English language only.

Conformément aux dispositions de la Résolution du Conseil 15/1993, ce document est distribué en version anglaise seulement.

To expedite distribution, this document is circulated as received from the committee secretariat. ISO Central Secretariat work of editing and text composition will be undertaken at publication stage.

Pour accélérer la distribution, le présent document est distribué tel qu'il est parvenu du secrétariat du comité. Le travail de rédaction et de composition de texte sera effectué au Secrétariat central de l'ISO au stade de publication.

THIS DOCUMENT IS A DRAFT CIRCULATED FOR COMMENT AND APPROVAL. IT IS THEREFORE SUBJECT TO CHANGE AND MAY NOT BE REFERRED TO AS AN INTERNATIONAL STANDARD UNTIL PUBLISHED AS SUCH.

IN ADDITION TO THEIR EVALUATION AS BEING ACCEPTABLE FOR INDUSTRIAL, TECHNOLOGICAL, COMMERCIAL AND USER PURPOSES, DRAFT INTERNATIONAL STANDARDS MAY ON OCCASION HAVE TO BE CONSIDERED IN THE LIGHT OF THEIR POTENTIAL TO BECOME STANDARDS TO WHICH REFERENCE MAY BE MADE IN NATIONAL REGULATIONS.

RECIPIENTS OF THIS DRAFT ARE INVITED TO SUBMIT, WITH THEIR COMMENTS, NOTIFICATION OF ANY RELEVANT PATENT RIGHTS OF WHICH THEY ARE AWARE AND TO PROVIDE SUPPORTING DOCUMENTATION.

PDF disclaimer

This PDF file may contain embedded typefaces. In accordance with Adobe's licensing policy, this file may be printed or viewed but shall not be edited unless the typefaces which are embedded are licensed to and installed on the computer performing the editing. In downloading this file, parties accept therein the responsibility of not infringing Adobe's licensing policy. The ISO Central Secretariat accepts no liability in this area.

Adobe is a trademark of Adobe Systems Incorporated.

Details of the software products used to create this PDF file can be found in the General Info relative to the file; the PDF-creation parameters were optimized for printing. Every care has been taken to ensure that the file is suitable for use by ISO member bodies. In the unlikely event that a problem relating to it is found, please inform the Central Secretariat at the address given below.

iTeh STANDARD PREVIEW
(standards.iteh.ai)
Full standard:
<https://standards.iteh.ai/catalog/standards/sist/d84d5300-a1a1-402b-bdf9-37c87f717633/iso-8820-9-2014>

Copyright notice

This ISO document is a Draft International Standard and is copyright-protected by ISO. Except as permitted under the applicable laws of the user's country, neither this ISO draft nor any extract from it may be reproduced, stored in a retrieval system or transmitted in any form or by any means, electronic, photocopying, recording or otherwise, without prior written permission being secured.

Requests for permission to reproduce should be addressed to either ISO at the address below or ISO's member body in the country of the requester.

ISO copyright office
Case postale 56 • CH-1211 Geneva 20
Tel. + 41 22 749 01 11
Fax + 41 22 749 09 47
E-mail copyright@iso.org
Web www.iso.org

Reproduction may be subject to royalty payments or a licensing agreement.

Violators may be prosecuted.

Contents

	Page
1	Scope 1
2	Normative references 1
3	Terms and definitions 1
4	Marking, labelling and colour coding 1
5	Tests and requirements 2
5.1	General 2
5.2	Voltage drop and connection resistance 4
5.3	Transient current cycling 6
5.4	Environmental conditions 7
5.5	Operating time-rating 7
5.6	Current steps 7
5.7	Breaking capacity 7
5.8	Strength of terminals 8
6	Dimensions 9
6.1	Designation example 11
7	Test fixture 11

iTeh STANDARD PREVIEW
 (standards.iteh.ai)
 Full standard:
<https://standards.iteh.ai/catalog/standards/sist/c84d5300-a1a1-402b-bdf9-37c87f717633/iso-8820-9-2014>

Foreword

ISO (the International Organization for Standardization) is a worldwide federation of national standards bodies (ISO member bodies). The work of preparing International Standards is normally carried out through ISO technical committees. Each member body interested in a subject for which a technical committee has been established has the right to be represented on that committee. International organizations, governmental and non-governmental, in liaison with ISO, also take part in the work. ISO collaborates closely with the International Electrotechnical Commission (IEC) on all matters of electrotechnical standardization.

International Standards are drafted in accordance with the rules given in the ISO/IEC Directives, Part 2.

The main task of technical committees is to prepare International Standards. Draft International Standards adopted by the technical committees are circulated to the member bodies for voting. Publication as an International Standard requires approval by at least 75 % of the member bodies casting a vote.

Attention is drawn to the possibility that some of the elements of this document may be the subject of patent rights. ISO shall not be held responsible for identifying any or all such patent rights.

ISO 8820-9 was prepared by Technical Committee ISO/TC 22, *Road vehicles*, Subcommittee SC 3, *Electrical and electronic equipment*.

ISO 8820 consists of the following parts, under the general title *Road vehicles — Fuse-links*:

- *Part 1: Definitions and general test requirements*
- *Part 2: User's guide*
- *Part 3: Fuse-link's with tabs (blade type) Type C (medium), Type E (high current) and Type F (miniature)*
- *Part 4: Fuse-links with female contacts (Type A) and bolt-in contacts (Type B) and their test fixtures*
- *Part 5: Fuse links with axial terminals (strip fuse-links) Type SF30 and SF51 and test fixture*
- *Part 6 Single bolt fuse-links*
- *Part 7: Fuse-links with a rated voltage of 450V (Type G)*
- *Part 8: Fuse-links with bolt-in contacts (Type H, I) with a rated voltage of 450V*
- *Part 9: Fuse-links miniature low profile (Type D)*

Road vehicles — Fuse-links —

Part 9:

Fuse-links with shortened tabs (Type D)

1 Scope

This standard specifies fuse-links with shortened tabs (Type D) for use in road vehicles. It establishes, for these fuse-link types, the rated current, test procedures, performance requirements and dimensions.

This standard is applicable to fuse-links with a rated voltage of 58 V, a current rating of $\leq 30\text{A}$ and a breaking capacity of 1000 A intended for use in road vehicles.

This part of ISO 8820 is intended to be used in conjunction with ISO 8820-1 and with ISO 8820-2. The numbering of its clauses corresponds to that of ISO 8820-1 whose requirements are applicable, except where modified by requirements particular to this part of ISO 8820.

2 Normative references

The following standards contain provisions, which through reference in this text, constitute provisions of this part of ISO 8820. At the time of publication, the editions indicated were valid. All standards are subject to revision, and parties to agreements based on this part of ISO 8820 are encouraged to investigate the possibility of applying the most recent editions of the standards indicated below. Members of IEC and ISO maintain registers of currently valid International standards.

ISO 6722, *Road vehicles – 60V and 600V single core cables – Dimensions, test methods and requirements.*

ISO 8820-1, *Road vehicles – Fuse-links - Part 1: Definitions and general test requirements*

ISO 8820-2, *Road vehicles – Fuse-links - Part 2: User's guide*

3 Terms and definitions

For the purposes of this part of ISO 8820, the terms and definitions given in ISO 8820-1 apply.

4 Marking, labelling and colour coding

See ISO 8820-1 and table 1.

Table 1 — Fuse-link colour coding

Current rating A	Colour
1	Black
2	Grey
3	Violet
4	Pink
5	Tan / Light brown
7,5	Brown
10	Red
15	Blue
20	Yellow
25	White ¹⁾
30	Green

¹⁾ for transparent fuse bodies "white" means no colour in the plastic material is added

5 Tests and requirements

5.1 General

In addition to carrying out the test procedures in accordance with ISO 8820-1 the following criteria shall apply:

Tests shall be performed following the test sequences in table 2.

The test fixtures for electrical tests shall be designed in accordance with figure 1.

Fuse-links according to this part of ISO 8820 shall provide for visible evidence of an open fuse element.

5.1.1 Test sequence

Table 2 — Test sequence

No	Test	Clause	Sample groups ^{*)}							
			1	2	3	4	5	6	7	
1	Dimensions	6	X	X	X	--	--	--	--	
2	Marking, labelling and colour coding	4	X	X	X	X	X	X	X	
3	Fuse-link voltage drop	5.2	X	X	X	--	--	--	--	
4	Strength of terminals	5.8	X	X	X	--	--	--	--	
5	Environmental conditions	Climatic load	--	--	--	X	--	--	--	
		Chemical load	--	--	--	--	X	--	--	
		Mechanical load	--	--	--	--	--	X	--	
6	Transient current cycling	5.3	--	--	--	--	--	--	X	
7	Fuse-link voltage drop	5.2	--	--	--	X	X	X	X	
8	Current steps	5.6	--	--	X	--	--	--	--	
9	Breaking capacity	5.7	X	--	--	--	--	--	--	
10	Operating time rating test	I_R	--	X	--	X	X	X	X	X
		$1,35 I_R$	--	Y	--	Y	Y	Y	Y	Y
		$1,6 I_R$	--	Y	--	Y	Y	Y	Y	Y
		$2 I_R$	--	Y	--	Y	Y	Y	Y	Y
		$3,5 I_R$	--	Y	--	Y	Y	Y	Y	Y
		$6 I_R$	--	Y	--	Y	Y	Y	Y	Y
11	Strength of terminals	5.8	X	X	X	X	X	X	X	

^{*)} – Each sample group shall contain a minimum of 10 fuse-links for each current rating.
 Y – For these operating time tests the sample groups 2, 4, 5, 6 and 7 shall be divided equally. These fuse-links are intended to be subjected to a single operating time test only.
 -- – Not required

5.1.2 Test cable sizes

Test cable sizes shall be as given in table 3. All tests for a particular fuse-link rating shall be performed using the same cable size.

Test cable sizes are specified to allow comparative fuse-link tests to be carried out. The cable size specified herein does not necessarily indicate the size of cable to be used in the vehicle application.

Table 3 — Test cable sizes

Rated current I_R A	Conductor cross-sectional area ¹⁾ mm ²	Length mm
1	0,35	500 ± 50
2		
3		
4		
5	0,5	
7,5	0,75	
10	1,0	
15	1,5	
20	2,5	
25		
30	4,0	

¹⁾ Conductor material according ISO 6722

5.2 Voltage drop and connection resistance

5.2.1 Tests

The voltage drop U_{AB} shall be measured at points A and B across the fuse-link tabs as shown in figure 1. The connection resistance shall be measured at the points A, C and B, D.

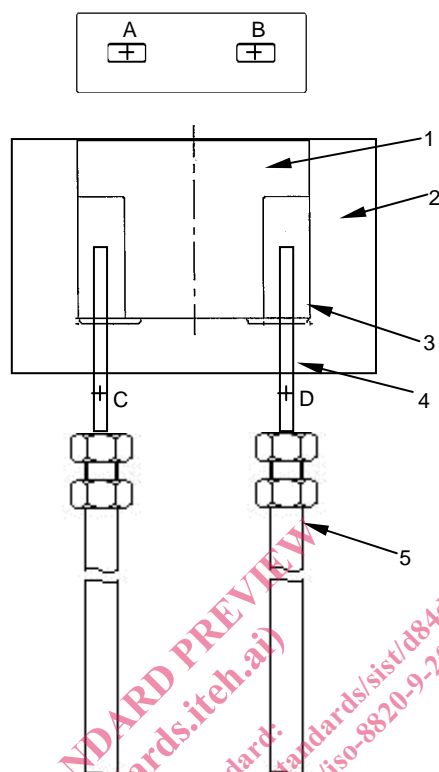

Key:

- 1 Fuse-link
- 2 Test fixture
- 3 Fuse blade
- 4 Test clip (as defined in table 8)
- 5 Cable size according to table 3

NOTE Points A and B are the measuring points for the voltage drop.
Points A, C and B, D are the measuring points for connection resistance.

Figure 1 — Test schematic (Type D)

5.2.2 Requirements

See table 4.