

ETSI EN 303 105-2 V1.1.1 (2022-03)



**Digital Video Broadcasting (DVB);  
Next Generation broadcasting system to Handheld,  
physical layer specification (DVB-NGH);  
Part 2: MIMO Profile**

[ETSI EN 303 105-2 V1.1.1 \(2022-03\)](https://standards.iteh.ai/catalog/standards/sist/21b4492d-b502-4a30-96b4-b2a691f51757/etsi-en-303-105-2-v1-1-1-2022-03)  
[https://standards.iteh.ai/catalog/standards/sist/21b4492d-  
b502-4a30-96b4-b2a691f51757/etsi-en-303-105-2-v1-1-  
1-2022-03](https://standards.iteh.ai/catalog/standards/sist/21b4492d-b502-4a30-96b4-b2a691f51757/etsi-en-303-105-2-v1-1-1-2022-03)

**EBU DVB<sup>®</sup>**

---

**Reference**

DEN/JTC-DVB-373-2

---

**Keywords**

audio, broadcasting, data, digital, DVB, hybrid, MIMO, MPEG, radio, satellite, terrestrial TV, video

**ETSI**650 Route des Lucioles  
F-06921 Sophia Antipolis Cedex - FRANCE

Tel.: +33 4 92 94 42 00 Fax: +33 4 93 65 47 16

Siret N° 348 623 562 00017 - APE 7112B  
Association à but non lucratif enregistrée à la  
Sous-Préfecture de Grasse (06) N° w061004871

---

**Important notice**

The present document can be downloaded from:

<http://www.etsi.org/standards-search>

The present document may be made available in electronic versions and/or in print. The content of any electronic and/or print versions of the present document shall not be modified without the prior written authorization of ETSI. In case of any existing or perceived difference in contents between such versions and/or in print, the prevailing version of an ETSI deliverable is the one made publicly available in PDF format at [www.etsi.org/deliver](http://www.etsi.org/deliver).

Users of the present document should be aware that the document may be subject to revision or change of status.

Information on the current status of this and other ETSI documents is available at

<https://portal.etsi.org/TB/ETSIDeliverableStatus.aspx>

If you find errors in the present document, please send your comment to one of the following services:

<https://www.etsi.org/People/CommitteeSupportStaff.aspx>

If you find a security vulnerability in the present document, please report it through our

Coordinated Vulnerability Disclosure Program:

<https://www.etsi.org/standards/coordinated-vulnerability-disclosure>

---

**Notice of disclaimer & limitation of liability**

The information provided in the present deliverable is directed solely to professionals who have the appropriate degree of experience to understand and interpret its content in accordance with generally accepted engineering or other professional standard and applicable regulations.

No recommendation as to products and services or vendors is made or should be implied.

In no event shall ETSI be held liable for loss of profits or any other incidental or consequential damages.

Any software contained in this deliverable is provided "AS IS" with no warranties, express or implied, including but not limited to, the warranties of merchantability, fitness for a particular purpose and non-infringement of intellectual property rights and ETSI shall not be held liable in any event for any damages whatsoever (including, without limitation, damages for loss of profits, business interruption, loss of information, or any other pecuniary loss) arising out of or related to the use of or inability to use the software.

---

**Copyright Notification**

No part may be reproduced or utilized in any form or by any means, electronic or mechanical, including photocopying and microfilm except as authorized by written permission of ETSI.

The content of the PDF version shall not be modified without the written authorization of ETSI.

The copyright and the foregoing restriction extend to reproduction in all media.

© ETSI 2022.

© European Broadcasting Union 2022.

All rights reserved.

# Contents

Intellectual Property Rights .....	4
Foreword.....	4
Modal verbs terminology.....	5
1 Scope .....	6
2 References .....	6
2.1 Normative references .....	6
2.2 Informative references.....	6
3 Definition of terms, symbols and abbreviations.....	6
3.1 Terms.....	6
3.2 Symbols.....	6
3.3 Abbreviations .....	7
4 DVB-NGH MIMO system definition.....	7
4.1 System overview and architecture.....	7
4.1.1 Overview .....	7
4.1.2 Bit interleaved coding and modulation, MISO and MIMO precoding .....	7
4.1.3 FEC encoding and interleaving inside a FEC block .....	8
4.1.4 Modulation and component interleaving .....	8
4.1.5 Time interleaving (inter-frame convolutional interleaving plus intra-frame block interleaving) .....	8
4.1.6 Frame building, frequency interleaving.....	9
4.1.7 OFDM generation.....	9
5 Transmit/receive system compatibility.....	9
6 Bit interleaver.....	10
7 Complex symbol generation.....	12
8 Power imbalance .....	13
9 MIMO precoding.....	14
9.1 Overview .....	14
9.2 Spatial-multiplexing encoding.....	15
9.3 Phase hopping .....	15
10 eSFN processing for MIXO .....	16
11 SISO/MIXO options for P1, aP1 and P2 symbols.....	16
12 Layer 1 signalling data specific for the MIMO Profile .....	16
12.1 P1 and additional P1 signalling data.....	16
12.2 L1-PRE signalling data .....	17
12.3 L1-POST signalling data.....	18
12.3.1 L1-POST-configurable signalling data .....	18
12.3.2 L1-POST-dynamic signalling data .....	19
12.3.3 In-band signalling type A .....	19
<b>Annex A (informative): Bibliography.....</b>	<b>20</b>
History .....	21

# Intellectual Property Rights

## Essential patents

IPRs essential or potentially essential to normative deliverables may have been declared to ETSI. The declarations pertaining to these essential IPRs, if any, are publicly available for **ETSI members and non-members**, and can be found in ETSI SR 000 314: "*Intellectual Property Rights (IPRs); Essential, or potentially Essential, IPRs notified to ETSI in respect of ETSI standards*", which is available from the ETSI Secretariat. Latest updates are available on the ETSI Web server (<https://ipr.etsi.org/>).

Pursuant to the ETSI Directives including the ETSI IPR Policy, no investigation regarding the essentiality of IPRs, including IPR searches, has been carried out by ETSI. No guarantee can be given as to the existence of other IPRs not referenced in ETSI SR 000 314 (or the updates on the ETSI Web server) which are, or may be, or may become, essential to the present document.

## Trademarks

The present document may include trademarks and/or tradenames which are asserted and/or registered by their owners. ETSI claims no ownership of these except for any which are indicated as being the property of ETSI, and conveys no right to use or reproduce any trademark and/or tradename. Mention of those trademarks in the present document does not constitute an endorsement by ETSI of products, services or organizations associated with those trademarks.

**DECT™**, **PLUGTESTS™**, **UMTS™** and the ETSI logo are trademarks of ETSI registered for the benefit of its Members. **3GPP™** and **LTE™** are trademarks of ETSI registered for the benefit of its Members and of the 3GPP Organizational Partners. **oneM2M™** logo is a trademark of ETSI registered for the benefit of its Members and of the oneM2M Partners. **GSM®** and the GSM logo are trademarks registered and owned by the GSM Association.

## Foreword

(standards.iteh.ai)

This European Standard (EN) has been produced by Joint Technical Committee (JTC) Broadcast of the European Broadcasting Union (EBU), Comité Européen de Normalisation ELECTrotechnique (CENELEC) and the European Telecommunications Standards Institute (ETSI).

**NOTE:** The EBU/ETSI JTC Broadcast was established in 1990 to co-ordinate the drafting of standards in the specific field of broadcasting and related fields. Since 1995 the JTC Broadcast became a tripartite body by including in the Memorandum of Understanding also CENELEC, which is responsible for the standardization of radio and television receivers. The EBU is a professional association of broadcasting organizations whose work includes the co-ordination of its members' activities in the technical, legal, programme-making and programme-exchange domains. The EBU has active members in about 60 countries in the European broadcasting area; its headquarters is in Geneva.

European Broadcasting Union  
CH-1218 GRAND SACONNEX (Geneva)  
Switzerland  
Tel: +41 22 717 21 11  
Fax: +41 22 717 24 81

The DVB Project is an industry-led consortium of broadcasters, manufacturers, network operators, software developers, regulators and others from around the world committed to designing open, interoperable technical specifications for the global delivery of digital media and broadcast services. DVB specifications cover all aspects of digital television from transmission through interfacing, conditional access and interactivity for digital video, audio and data. The consortium came together in 1993.

The present document is part 2 of a multi-part deliverable. Full details of the entire series can be found in part 1 [1].

National transposition dates	
Date of adoption of this EN:	24 March 2022
Date of latest announcement of this EN (doa):	30 June 2022
Date of latest publication of new National Standard or endorsement of this EN (dop/e):	31 December 2022
Date of withdrawal of any conflicting National Standard (dow):	31 December 2022

---

## Modal verbs terminology

In the present document "shall", "shall not", "should", "should not", "may", "need not", "will", "will not", "can" and "cannot" are to be interpreted as described in clause 3.2 of the [ETSI Drafting Rules](#) (Verbal forms for the expression of provisions).

"must" and "must not" are **NOT** allowed in ETSI deliverables except when used in direct citation.

# iTeh STANDARD PREVIEW (standards.iteh.ai)

[ETSI EN 303 105-2 V1.1.1 \(2022-03\)](#)  
<https://standards.iteh.ai/catalog/standards/sist/21b4492d-b502-4a30-96b4-b2a691f51757/etsi-en-303-105-2-v1-1-1-2022-03>

---

# 1 Scope

The present document describes the next generation transmission system for digital terrestrial MIMO broadcasting to handheld terminals making use of multi-aerial structures at the transmitting and receiving ends. It specifies the differences of the MIMO Profile physical layer part to the physical layer part of the Base Profile ETSI EN 303 105-1 [1] - from the input streams to the transmitted signals. This transmission system is intended for carrying Transport Streams or generic data streams feeding linear and non-linear applications like television, radio and data services. DVB-NGH terminals might also process DVB-T2-lite signals.

---

## 2 References

### 2.1 Normative references

References are either specific (identified by date of publication and/or edition number or version number) or non-specific. For specific references, only the cited version applies. For non-specific references, the latest version of the referenced document (including any amendments) applies.

Referenced documents which are not found to be publicly available in the expected location might be found at <https://docbox.etsi.org/Reference/>.

NOTE: While any hyperlinks included in this clause were valid at the time of publication, ETSI cannot guarantee their long term validity.

The following referenced documents are necessary for the application of the present document.

- [1] ETSI EN 303 105-1: "Digital Video Broadcasting (DVB); Next Generation broadcasting system to Handheld, physical layer specification (DVB-NGH); Part 1: Base Profile".

### 2.2 Informative references

References are either specific (identified by date of publication and/or edition number or version number) or non-specific. For specific references, only the cited version applies. For non-specific references, the latest version of the referenced document (including any amendments) applies.

NOTE: While any hyperlinks included in this clause were valid at the time of publication, ETSI cannot guarantee their long term validity.

The following referenced documents are not necessary for the application of the present document but they assist the user with regard to a particular subject area.

- [i.1] ETSI EN 303 105-4: "Digital Video Broadcasting (DVB); Next Generation broadcasting system to Handheld, physical layer specification (DVB-NGH); Part 4: Hybrid MIMO Profile".

---

## 3 Definition of terms, symbols and abbreviations

### 3.1 Terms

For the purposes of the present document, the terms given in ETSI EN 303 105-1 [1] apply.

### 3.2 Symbols

For the purposes of the present document, the symbols given in ETSI EN 303 105-1 [1] apply.

### 3.3 Abbreviations

For the purposes of the present document, the abbreviations given in ETSI EN 303 105-1 [1] apply.

## 4 DVB-NGH MIMO system definition

### 4.1 System overview and architecture

#### 4.1.1 Overview

MIMO transmission options are included in the optional MIMO Profile - reflected by the present document - in order to exploit the diversity and capacity advantages made possible by the use of multiple transmission elements at the transmitter and receiver. Channel estimation suitable for MIMO is provided by an appropriate pilot structure, identical to that provided in the Base Profile ETSI EN 303 105-1 [1] for MISO frames. The term 'MIXO frames' encompasses all frames containing such pilots. MIMO may hence form part of a transmission including MISO PLPs as well as SISO frames as defined in the Base Profile [1]. Within MIXO frames, different schemes may be applied to constituent PLPs according to the desired transmission characteristics; for instance MISO is specified for L1 signalling and may also be used for any other low-rate high-robustness transmission. Rate 2 MIMO, which increases the data multiplexing rate by sending distinct information from each transmit element, can be chosen where high data throughput efficiency is the primary goal.

In the following clauses, the differences to the Base Profile ETSI EN 303 105-1 [1] are outlined with reference to their Base Profile [1] counterparts.

Compared to the Base Profile [1], only the BICM and the OFDM generation stage contains functional differences.

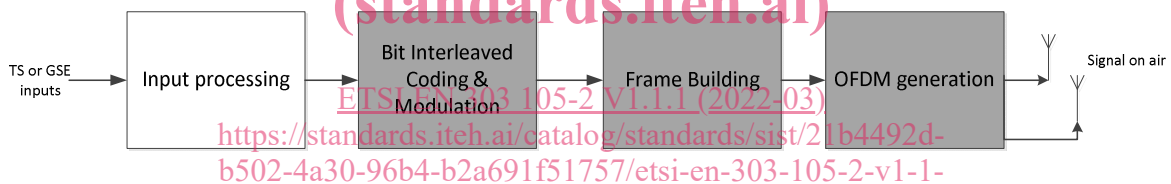

NOTE: Blocks differing from the Base Profile ETSI EN 303 105-1 [1] are shaded to grey.

**Figure 1: High level NGH physical layer block diagram of the MIMO Profile**

#### 4.1.2 Bit interleaved coding and modulation, MISO and MIMO precoding

The block diagram illustrating the functional differences in the BICM stage is shown in figure 2.

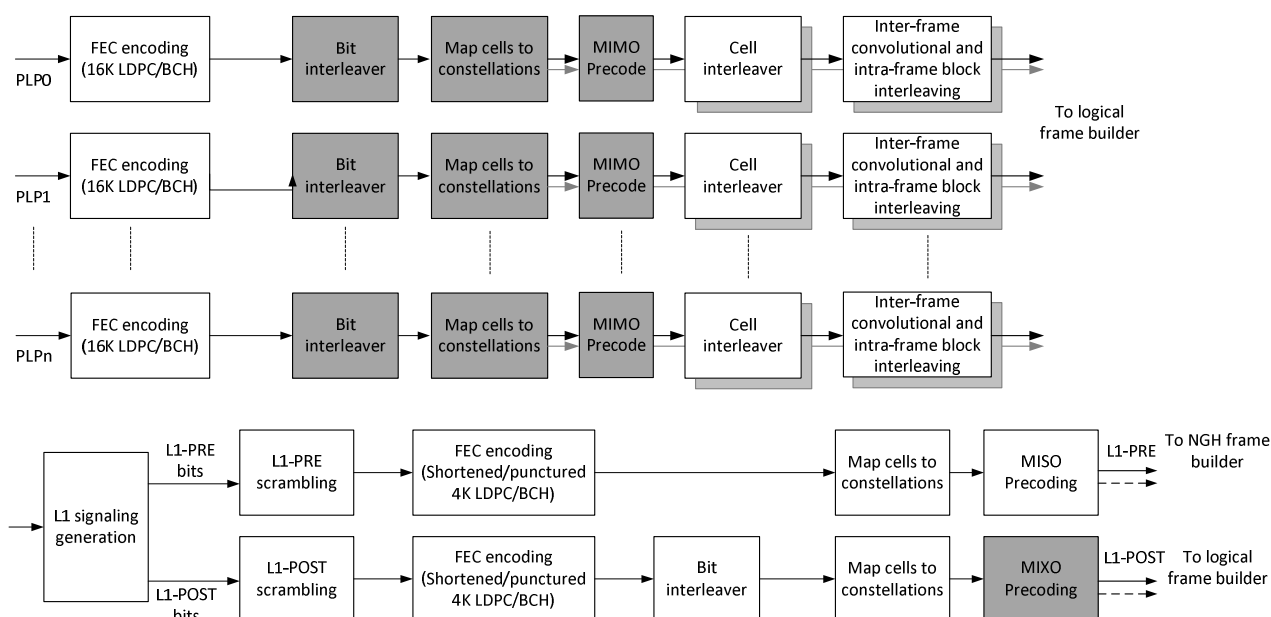

**Figure 2: Bit Interleaved Coding and Modulation (BICM) of the MIMO Profile**

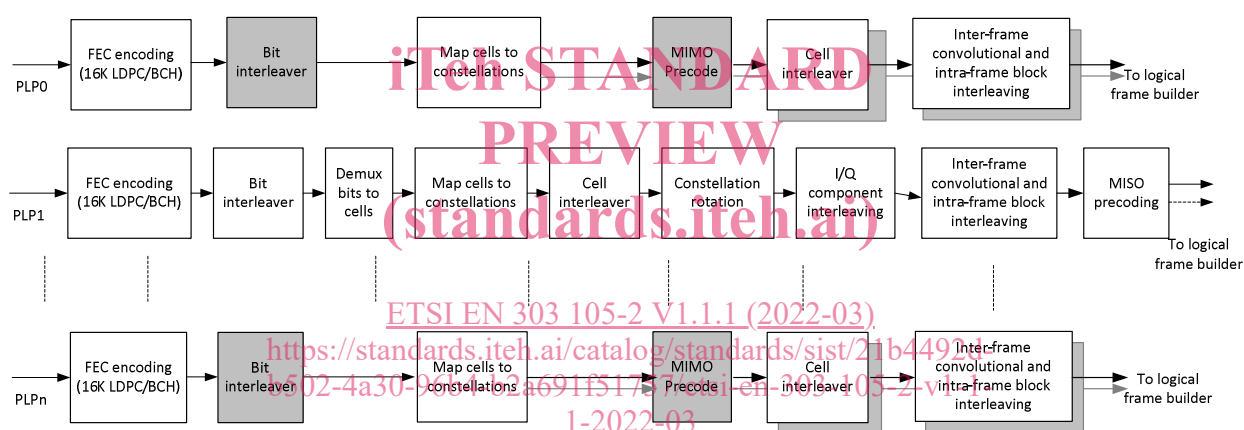

NOTE: Layer 1 signalling as in figure 2 above.

**Figure 3: Bit Interleaved Coding and Modulation (BICM) with mixed MIMO and MISO PLPs**

### 4.1.3 FEC encoding and interleaving inside a FEC block

MIMO PLPs within the MIMO Profile - reflected by the present document - employ a revised bit interleaver intended to simplify iterative MIMO decoding at the receiver. The Base Profile ETSI EN 303 105-1 [1] bit to cell demultiplexing is no longer explicitly present.

### 4.1.4 Modulation and component interleaving

The constellation is non-rotated QPSK, 16-QAM and 64-QAM. The constellation may be the same or different on the output MIMO pair depending on the chosen operational mode.

### 4.1.5 Time interleaving (inter-frame convolutional interleaving plus intra-frame block interleaving)

Since the time interleaving is carried out after the generation of two MIMO streams there are two parallel time interleavers. The time interleaving applied to both MIMO streams is identical. To keep the total memory requirement the same, each of these MIMO streams has half the maximum depth as the Base Profile [1].



### 4.1.6 Frame building, frequency interleaving

MIMO frames are built according to figure 4. This is the same architecture as the Base Profile [1] except for the allocation of space for the aP1 symbol.

The frequency interleaver is a pairwise interleaver defined in Base Profile [1], clause 9.10.

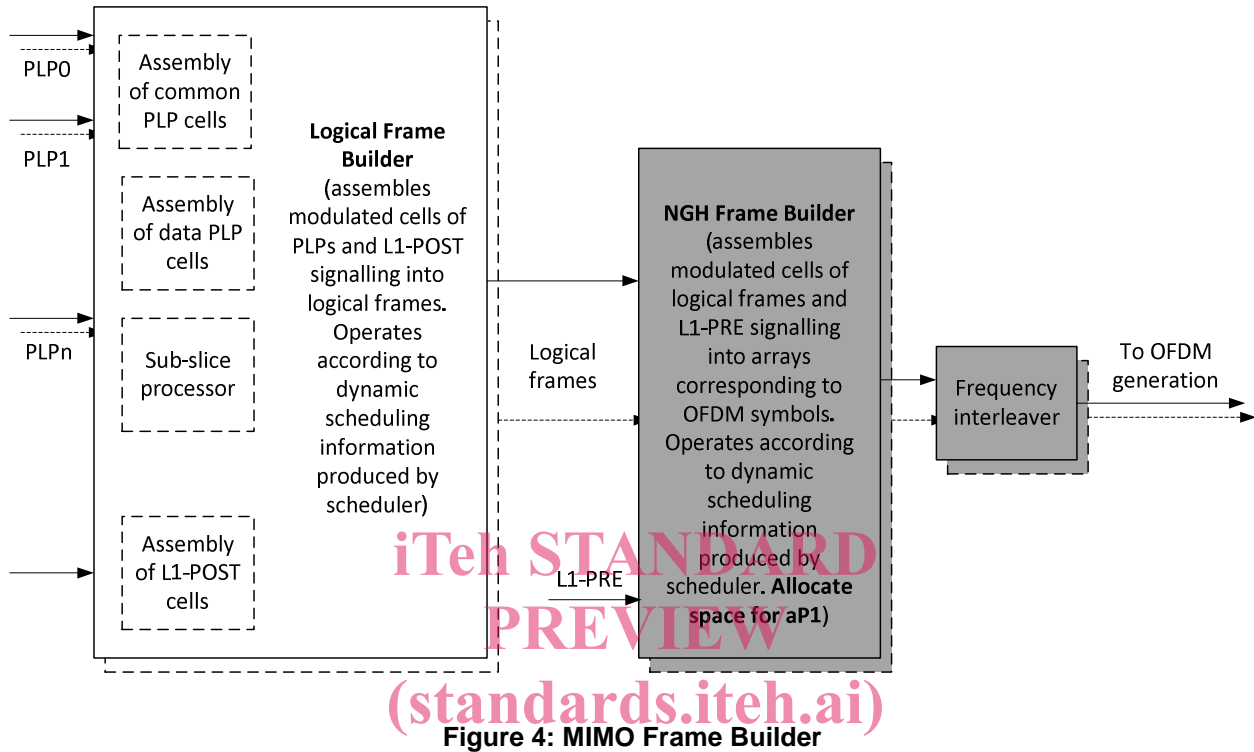

### 4.1.7 OFDM generation

The ACE PAPR technique cannot be applied to frames of preamble format "NGH-MIMO".

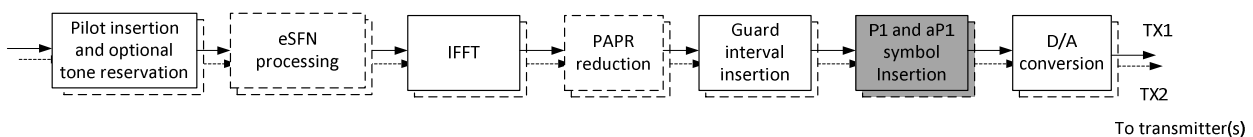

## 5 Transmit/receive system compatibility

To make use of the MIMO Profile reflected by the present document, the proposed transmitter hardware shall include individually-fed cross-polar antennas (Horizontal (HP) and Vertical POLARIZATION (VP)). In addition, to receive and decode the MIMO signal, a cross-polar pair of antennas is necessary at the receive terminal.

In a given PLP, only one of MISO or MIMO encoding may be used, i.e. they are not cascable.

The bit interleaver for the MIMO Profile described below in clause 6 is a replacement for that described in ETSI EN 303 105-1 [1].

## 6 Bit interleaver

The bit interleaver used for MIMO PLPs is different from the one used in the Base Profile [1]. Figure 6 shows the basic block diagram.

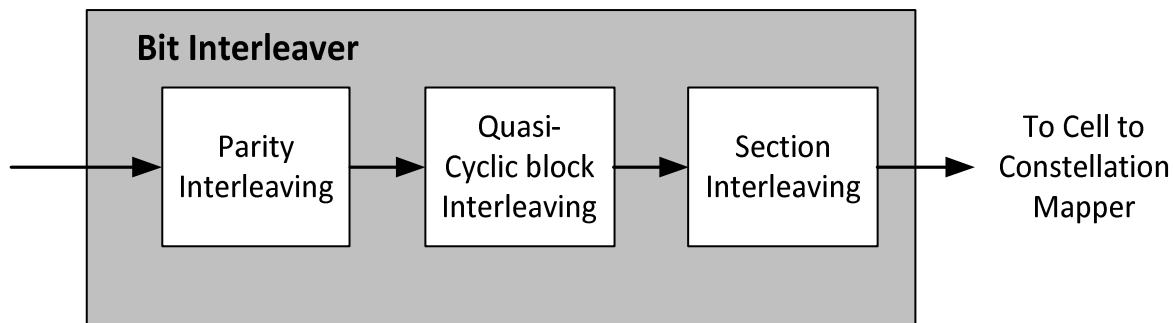

**Figure 6: Bit Interleaver of the MIMO Profile**

In order to allow for a more efficient receiver implementation, the new bit interleaver is adapted to the quasi-cyclic structure of the LDPC code. The new bit interleaver for MIMO consists of two components: a parity interleaver and a parallel bit interleaver.

The parity interleaver is identical to the one used in the bit interleaver of the Base Profile (see ETSI EN 303 105-1 [1], clause 6.1.4). Its role is to convert the staircase structure of the parity part of the LDPC parity-check matrix into a quasi-cyclic structure similar to the information-part of the matrix. At the output of the parity interleaver the LDPC codeword consists of 45 adjacent Quasi-cyclic Blocks (QB), each block consisting of 360 bits (note also the  $Q_{ldpc}$  parameter in ETSI EN 303 105-1 [1], clause 6.1.2). The parity-interleaved codeword is interleaved by the parallel bit interleaver and then mapped to a sequence of Spatial-Multiplexing (SM) blocks of  $N_{\text{bpcu}}$  bits each, as shown in figure 7 for  $N_{\text{bpcu}} = 8$ .

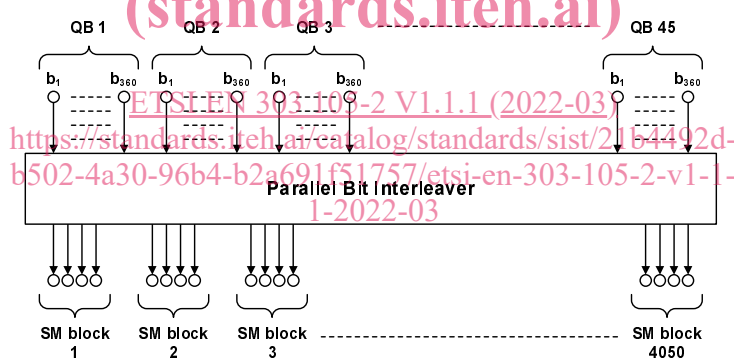

**Figure 7: Parallel bit interleaver, QB and section interleaver part**

The parallel interleaver in turn comprises two stages: a QB interleaver and a section interleaver.

The QB interleaver permutes the order of the 45 Quasi-cyclic Blocks (QBs) of the LDPC codeword. The corresponding QB permutation is optimized for each combination of  $N_{\text{bpcu}}$ , code rate, and power imbalance. Tables 1 to 3 show these permutations for  $N_{\text{bpcu}} = 6, 8$  and  $10$ , respectively, each table containing the permutations for all code rates and power imbalances. The QB indices range from 1 to 45.

