**Dentistry — Dental furnace — Test
method for temperature measurement
with separate thermocouple**

*Médecine bucco-dentaire — Four dentaire — Méthode d'essai pour le
mesurage de la température au moyen d'un thermocouple*

iTeh STANDARD PREVIEW
(standards.iteh.ai)

[ISO 13078:2013](https://standards.iteh.ai/catalog/standards/sist/9cce6310-4538-4d65-a8ff-9434109702c2/iso-13078-2013)

<https://standards.iteh.ai/catalog/standards/sist/9cce6310-4538-4d65-a8ff-9434109702c2/iso-13078-2013>



iTeh STANDARD PREVIEW (standards.iteh.ai)

ISO 13078:2013

<https://standards.iteh.ai/catalog/standards/sist/9cce6310-4538-4d65-a8ff-9434109702c2/iso-13078-2013>



COPYRIGHT PROTECTED DOCUMENT

© ISO 2013

All rights reserved. Unless otherwise specified, no part of this publication may be reproduced or utilized in any form or by any means, electronic or mechanical, including photocopying and microfilm, without permission in writing from either ISO at the address below or ISO's member body in the country of the requester.

ISO copyright office
Case postale 56 • CH-1211 Geneva 20
Tel. + 41 22 749 01 11
Fax + 41 22 749 09 47
E-mail copyright@iso.org
Web www.iso.org

Published in Switzerland

Foreword

ISO (the International Organization for Standardization) is a worldwide federation of national standards bodies (ISO member bodies). The work of preparing International Standards is normally carried out through ISO technical committees. Each member body interested in a subject for which a technical committee has been established has the right to be represented on that committee. International organizations, governmental and non-governmental, in liaison with ISO, also take part in the work. ISO collaborates closely with the International Electrotechnical Commission (IEC) on all matters of electrotechnical standardization.

International Standards are drafted in accordance with the rules given in the ISO/IEC Directives, Part 2.

The main task of technical committees is to prepare International Standards. Draft International Standards adopted by the technical committees are circulated to the member bodies for voting. Publication as an International Standard requires approval by at least 75 % of the member bodies casting a vote.

Attention is drawn to the possibility that some of the elements of this document may be the subject of patent rights. ISO shall not be held responsible for identifying any or all such patent rights.

ISO 13078 was prepared by Technical Committee ISO/TC 106, *Dentistry*, Subcommittee SC 2, *Prosthetic materials*.

iTeh STANDARD PREVIEW (standards.iteh.ai)

[ISO 13078:2013](https://standards.iteh.ai/catalog/standards/sist/9cce6310-4538-4d65-a8ff-9434109702c2/iso-13078-2013)

<https://standards.iteh.ai/catalog/standards/sist/9cce6310-4538-4d65-a8ff-9434109702c2/iso-13078-2013>

Introduction

Dental furnaces are suitable for the manufacturing of metal-ceramic and all-ceramic restorations for use in dentistry. Dental furnaces are particularly used for firing or sintering, respectively, of dental opaques, dentine and enamel materials to the respective compatible substructure materials. Dental furnaces are also used for other applications such as oxidizing metallic substructures in preparation for porcelain firing, for melting pressable ceramics, for stain and glaze firing, etc. According to the current state of the art, the temperature of this process lies between 600 °C and 1 050 °C.

The firing result obtained is influenced by the accuracy of the actual temperature, which may be influenced by the different calibration processes applied by the manufacturers of dental furnaces as well as by the varying construction types of the dental furnaces currently on the market.

Despite the fact that different dental furnaces can have identical digital external displays, different results regarding the degree of firing can be identified when processing the same ceramics under otherwise similar conditions.

A different degree of firing does not only cause differences that can be judged directly by the human eye (e. g. colour and transparency), but also deviations that cannot be detected by eye. These are for instance the coefficient of thermal expansion, strength, and solubility of the dental opaque, dentine or enamel materials, and the bonding strength to its substructure. Such changes may result in clinical failures (e. g. fractures) as well as discoloration and changed aesthetics of the dental ceramic restoration.

This International Standard levels the currently existing differences between the final calibration of the dental furnaces based on the factory of origin through a final adjustment (that has to be carried out by all manufacturers in an identical way) of the temperature control in the firing chamber by means of a thermocouple at e.g. 800 °C.

Alternatively, the verification of the process can be carried out using the thermocouple at 700 °C or 900 °C.

ISO 13078:2013
<https://standards.iteh.ai/catalog/standards/sist/9cce6310-4538-4d65-a8ff-9434109702c2/iso-13078-2013>

Dentistry — Dental furnace — Test method for temperature measurement with separate thermocouple

1 Scope

This International Standard specifies a test method for the calibration of dental furnaces that are suitable for the heat treatment of silica-based dental ceramic restorations in the temperature range between 600 °C and 1 050 °C. This International Standard does not include furnaces intended to sinter zirconium oxide-frameworks (in the temperature range of 1 350°C or higher).

2 Normative references

The following referenced documents are indispensable for the application of this document. For dated references, only the edition cited applies. For undated references, the latest edition of the referenced document (including any amendments) applies.

ISO 1942, *Dentistry — Vocabulary*

ISO 6872, *Dentistry — Ceramic materials*

IEC 60584-1, *Thermocouples — Part 1: Reference tables*

IEC 60584-2, *Thermocouples — Part 2: Tolerances*

IEC 60584-3, *Thermocouples — Part 3: Extension and compensating cables — Tolerances and identification system*

<https://standards.iteh.ai/catalog/standards/sist/9cce6310-4538-4d65-a8ff-9434109702c2/iso-13078-2013>

3 Terms and definitions

For the purposes of this document, the terms and definitions given in ISO 1942, ISO 6872 and IEC 60584-1 and the following apply.

3.1

dental furnace

furnace in the firing chamber in which dental materials are treated thermally (i.e. fired or sintered, oxidized)

3.2

heating rate

rate of temperature increase

NOTE The heating rate is expressed in degrees Celsius per minute (°C/min).

3.3

holding time

period of time over which the desired temperature of the dental furnace is maintained until the time prescribed by the manufacturer, starting when the display of the dental furnace shows that the set test temperature has been achieved and the furnace temperature has stabilized

4 Test method

4.1 Test equipment and test products

4.1.1 Test fixture that positions the thermocouple in accordance with Figure 1. An example is:

- 1) type: honeycomb tray of cordierite; colour: light;

- 2) thickness: (11 ± 1) mm;
- 3) diameter: (60 ± 6) mm.

NOTE Any firing tray capable of enabling a thermocouple positioning according to Figure 1 may be used.

4.1.2 Dental furnace;

4.1.3 Thermocouple with, for example, the following specifications:

- 1) thermocouple platinum-10 % rhodium/platinum (Type S) in accordance with IEC 60584-1, with a tolerance of the thermoelectric voltage of class 1 in accordance with IEC 60584-2;
- 2) diameter of the legs: 0,5 mm in accordance with DIN 43732, Type C;
- 3) diameter of the head: $(1,5 \pm 0,5)$ mm.

NOTE Any thermocouple appropriately calibrated and adjusted for the given temperature-range (up to 1 050 °C) may be used.

4.1.4 Compensating cable for the thermocouple with a tolerance of the compensating cable of class 2 in accordance with IEC 60584-3. The cold junction voltage shall be compensated by the measuring device.

4.1.5 Temperature indicating device, certified or calibrated to be accurate to $\pm 1,2$ °C between 400 °C and 1 050 °C (e. g. HP data logger or Ezeçal)¹⁾.

iteh STANDARD PREVIEW
(standards.iteh.ai)

4.2 Procedure

4.2.1 Positioning of the thermocouple

ISO 13078:2013

The thermocouple is placed in the firing chamber of the dental furnace centrally with the thermocouple head located at a height of (20 ± 2) mm above the test fixture (see Figure 1). The distance between the thermocouple wires on the surface of the test fixture is (10 ± 5) mm.

The firing tray is fixed centrally in the firing chamber of the dental furnace.

Dimensions in millimetres

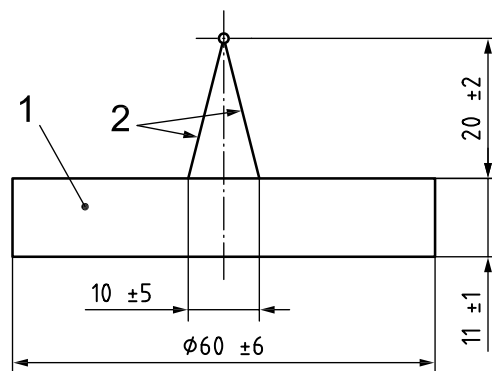

Key

- 1 firing tray (honeycomb tray)
- 2 thermocouple wires

Figure 1 — Positioning of the thermocouple on the firing tray

1) HP data logger and Ezeçal are examples of suitable commercially available products. This information is given for the convenience of the users of this standard only and does not constitute an endorsement of these products by ISO.

4.2.2 Heating phase and stand-by temperature

Prior to starting the adjustment, ensure that the dental furnace is operable.

NOTE For this purpose, generally, at the beginning the dental furnace is heated up in accordance with the manufacturer's information (this takes place partly automatically) and cooled down to stand-by temperature (e. g. 500 °C). It may be necessary to repeat this cycle several times.

The heating rate during the heating phase is 60 °C/min (± 5 °C). Regular atmosphere is required (no reduced pressure or vacuum).

4.2.3 Test temperature

The equipment shall be brought to the test temperature: e.g. 800 °C.

4.2.4 Holding time

The holding time starts when the display of the dental furnace shows that the set test temperature has been achieved and the furnace temperature has stabilized; the holding time is 1 min.

4.2.5 Adjustment procedure

At the end of the holding time, the temperature value determined by the external thermocouple is read off and recorded and (if required) the set point temperature of the dental furnace is adjusted to achieve the test temperature.

4.2.6 Verification

This adjustment procedure shall be repeated three times and the deviation between the readings of the furnace display and external thermocouple shall be recorded before every adjustment.

ISO 13078:2013

<https://standards.iteh.ai/catalog/standards/sist/9cce6310-4538-4d65-a8ff-9434109702c2/iso-13078-2013>

5 Test report

The test report shall contain the following information:

- a) model of the dental furnace;
- b) serial number;
- c) test equipment;
- d) protocols including a nominal/actual value comparison at the test temperature as well as the documentation of the relevant measures (adjustment);
- e) the deviation measured in the verification measurement according to 4.2.6;
- f) any parameters specified in this International Standard (heating rate, requirements for the measuring apparatus, type of the thermocouple used, etc.) should be part of the pre-printed form of the test protocol;
- g) date of test;
- h) name of testing laboratory or test technician identifier when conducting calibration as part of the quality control process.

Bibliography

- [1] ISO 9693-1, *Dentistry — Compatibility testing — Part 1: Metal-ceramic systems*²⁾
- [2] ISO 22112, *Dentistry — Artificial teeth for dental prostheses*
- [3] DIN 43732, *Measurement and control — Electrical temperature sensors — Thermocouples for thermocouple thermometers*

iTeh STANDARD PREVIEW
(standards.iteh.ai)

[ISO 13078:2013](https://standards.iteh.ai/catalog/standards/sist/9cce6310-4538-4d65-a8ff-9434109702c2/iso-13078-2013)

<https://standards.iteh.ai/catalog/standards/sist/9cce6310-4538-4d65-a8ff-9434109702c2/iso-13078-2013>

²⁾ Replaces ISO 9693:1999.

iTeh STANDARD PREVIEW
(standards.iteh.ai)

ISO 13078:2013

<https://standards.iteh.ai/catalog/standards/sist/9cce6310-4538-4d65-a8ff-9434109702c2/iso-13078-2013>