



Designation: D3700 – 07

Standard Practice for Obtaining LPG Samples Using a Floating Piston Cylinder¹

This standard is issued under the fixed designation D3700; the number immediately following the designation indicates the year of original adoption or, in the case of revision, the year of last revision. A number in parentheses indicates the year of last reapproval. A superscript epsilon (ϵ) indicates an editorial change since the last revision or reapproval.

1. Scope*

1.1 This practice covers the equipment and procedures for obtaining a representative sample of specification liquefied petroleum gas (LPG), such as specified in Specification D1835, GPA 2140, and comparable international standards. It may also be used for other natural gas liquid (NGL) products that are normally single phase (NGL mix, field butane, and so forth), defined in other industry specifications or contractual agreements.

1.2 This practice is not intended for non-specification products that contain significant quantities of undissolved gases (N_2 , CO_2), free water or other separated phases, such as raw or unprocessed gas/liquids mixtures and related materials. The same equipment can be used for these purposes, but additional precautions are generally needed to obtain representative samples of multi-phase products (see Appendix X1).

1.3 This practice includes recommendations for the location of a sample point in a line or vessel. It is the responsibility of the user to ensure that the sampling point is located so as to obtain a representative sample.

1.4 The values stated in SI units are to be regarded as standard. The values given in parentheses are for information only.

1.5 *This standard does not purport to address all of the safety concerns, if any, associated with its use. It is the responsibility of the user of this standard to establish appropriate safety and health practices, and determine the applicability of regulatory limitations prior to use.*

2. Referenced Documents

2.1 ASTM Standards:²

D1265 Practice for Sampling Liquefied Petroleum (LP) Gases, Manual Method

¹ This practice is under the jurisdiction of ASTM Committee D02 on Petroleum Products and Lubricants and is the direct responsibility of Subcommittee D02.H0 on Liquefied Petroleum Gas.

Current edition approved Feb. 15, 2007. Published March 2007. Originally approved in 1978. Last previous edition approved in 2001 as D3700-01. DOI: 10.1520/D3700-07.

² For referenced ASTM standards, visit the ASTM website, www.astm.org, or contact ASTM Customer Service at service@astm.org. For *Annual Book of ASTM Standards* volume information, refer to the standard's Document Summary page on the ASTM website.

D1835 Specification for Liquefied Petroleum (LP) Gases

2.2 GPA Standards:³

GPA 2174 Obtaining Liquid Hydrocarbon Samples for Analysis by Gas Chromatography

GPA 2140 Liquefied Petroleum Gas Specifications and Test Methods

3. Terminology

3.1 Definitions:

3.1.1 *floating piston cylinder (FPC)*—a high pressure sample container, with a free floating internal piston that effectively divides the container into two separate compartments.

3.1.2 *maximum fill density (reduced fill density)*—the volume of a container occupied by the sample, usually expressed as a percentage of the total capacity.

4. Summary of Practice

4.1 A liquid LPG sample is transferred under pressure from a sample point to a floating piston cylinder. The floating piston cylinder (FPC) is designed to collect liquid samples with no vaporization by displacing a piston against a pressurizing fluid (usually an inert gas). The piston serves as a physical barrier between the sample and the pressurizing fluid, at the sampling pressure. The position of the piston at the end of sampling indicates the percent fill of the sample cylinder.

4.2 It is the responsibility of the user of this practice to locate the sample point at a suitable location where the product being sampled is a representative, single phase, homogeneous liquid.

5. Significance and Use

5.1 This practice allows the collection of a representative sample of LPG that may contain trace volatile components such as methane, nitrogen, and ethane. Sampling by Practice D1265 may result in a small, but predictable loss of these lighter components. Practice D1265 is suitable for collecting samples for routine specification testing, as the small loss of light components is not significant under Specification D1835 specification requirements. Practice D3700 is recommended

³ Available from Gas Processors Association (GPA), 6526 E. 60th St., Tulsa, OK 74145.

*A Summary of Changes section appears at the end of this standard

whenever highly accurate determination of light components is required. For example, composition determined on samples collected according to Practice D3700 may be used to establish product value of NGL mixtures (see [Appendix X1](#)).

6. Interferences

6.1 An interference in a sampling procedure is anything which compromises the integrity of the sample.

6.2 Sample point location can give a non-representative sample due to solid or liquid contaminants, two phases, storage tank stratification, and so forth.

6.3 Reactivity of steel surfaces can remove or chemically alter trace reactive components such as H₂S, COS, and mercaptan.

6.4 A lubricant that is soluble in LPG can contaminate the sample.

6.5 Pre-charge gas can leak into the sample due to worn or damaged seals or poor surface finish (see [8.1](#)).

6.5.1 Consult manufacturer's guidelines for suitable procedure to verify a leak-free cylinder, such as pressure testing each side of the cylinder. It is also possible to analyze the sample for inert gas, or the inert gas for hydrocarbon, to detect leakage in either direction.

6.6 Failure to flush sample lines and *dead volumes* can result in contaminants in samples.

6.7 Sampling from stratified tanks, *dead zones* in flowing systems, or inappropriate time periods in composite sampling systems will result in non-representative samples.

7. Apparatus

7.1 Floating Piston Cylinder (FPC):

7.1.1 *Construction*, typically fabricated from corrosion resistant 316 stainless steel, in accordance with the pressure vessel certification requirements in the jurisdictions in which it is to be used, and through which it will be transported. Protective internal coatings or surface treatments are acceptable provided that they do not adversely affect the free movement of the piston, or effectiveness of the seals (see [Fig. 1](#)).

NOTE 1—At present, there is no international approval process for pressure cylinders. Cylinders require appropriate approval in each jurisdiction in which they are used or transported.

7.1.2 *Volume of Sample*, as required by the tests to be performed, typically 400 mL (that is, 80 % of 500 mL sample cylinder at 15°C).

NOTE 2—For safe handling of these cylinders under extremes of product or ambient temperatures, or both, the user must consider the effects of thermal expansion on the volume of product in the cylinder. For example, if a very cold product is sampled, -40°C (-40°F) for example, the cylinder should be expected to warm considerably before analysis is performed during transport and in the laboratory. During summer months, the temperature of the cylinder and product could reasonably be expected to rise to as high as 46°C (115°F) in hot environments. A cylinder initially filled to 80 % of its capacity will be over-pressured and the relief device(s) will activate under these conditions. Releases of this type are unexpected and dangerous. In such an extreme, but not uncommon case, the cylinder should not be filled more than approximately 60 % during the initial fill. Users should review ASTM/GPA volume correction factor calculations, or

data, or both, to determine the maximum fill for the product being sampled, but should always leave at least 10 % vapor space after allowing for the worst likely case of thermal expansion.

NOTE 3—It is recommended that users work with the manufacturer of these sample cylinders and sample collection systems any time ambient or product temperatures, or both, exceed the range of -29°C (-20°F) to 60°C (140°F). The consideration of extreme temperatures shall consider effects on metal, O-rings, valve seats, seals, gauges, relief devices, sample pump components and other devices and components in the system.

7.1.3 *Piston Position Indicator*—The FPC shall be equipped with a piston position indicator such as a magnetic follower, piston rod, or equivalent which can be used to indicate the sample volume to comply with the maximum percent fill (maximum fill density) allowed for storage and transportation.

7.1.3.1 Floating piston cylinders that are not equipped with a piston position indicator shall not be used without a procedure to allow the operator to verify fill density immediately after sampling prior to transport. Consult the authority having jurisdiction for acceptable procedures.

7.1.4 The cylinder shall include a mechanism to mix the sample in the sample chamber in case of stratified mixtures or water haze that may settle after sampling. This mechanism may be a mechanical mixer/vortex plate on a movable rod, a freely moving rolling ball or slider, magnetically coupled stirrer, or similar device. It is the responsibility of the user to provide sufficient mixing with the mechanism used to allow a representative sample to be withdrawn.

7.2 Lubricants used to lubricate or seal the floating piston, O ring seals, and other components shall be inert to LPG.

NOTE 4—DuPont Krytox AC or AD⁴ have been found to be suitable.

7.3 A safety relief device is required to prevent overpressure in the event that a cylinder becomes fully liquid filled (hydraulically locked) from either overfilling or liquid thermal expansion from excessive temperature increase.

7.3.1 A rupture disk or a self-resetting pressure relief valve shall be fitted to the cylinder to prevent overpressure from hydraulic filling due to temperature increase.

NOTE 5—DuPont KEL-F,⁴ or similar materials have been found to be suitable. Polytetrafluoroethylene (PTFE) or other materials that are prone to *creep* under pressure, and metal-to-metal valve seals are not recommended.

7.3.2 Users may not alter valves or safety relief devices that are part of a cylinder permit or exemption. (The USA has an exemption system and Canada has a permitting procedure for non-ASME or DOT cylinders.)

7.4 *Sampling System*—It is not possible to provide a single procedure that will be applicable for all sampling situations. Different procedures and sampling equipment may be required for sampling pipes, storage tanks, rail cars, trucks, and smaller storage vessels in order to obtain a representative sample (see [4.2](#)).

7.4.1 Sample equipment and procedures shall be designed and used to obtain representative samples of a product, and to

⁴ Registered trademarks of E. I. du Pont de Nemours and Company, Wilmington, DE.

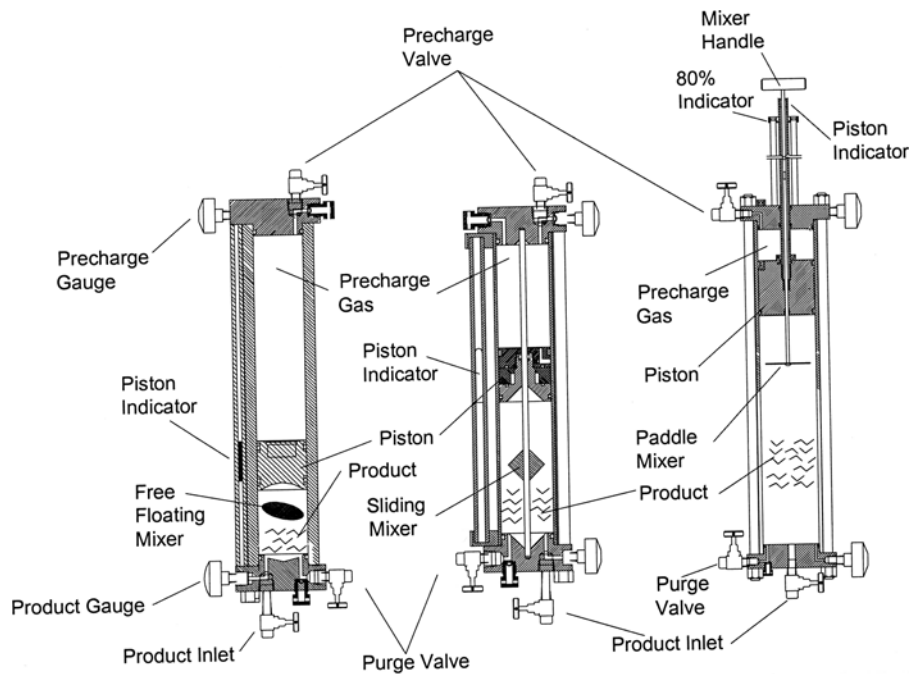

iTeh Standards
 (https://standards.iteh.ai)
 Document Preview

ASTM D3700

https://standards.iteh.ai/catalog/standards/sist/53cb0a6f-1...57e56bb50/astm-d3700-07

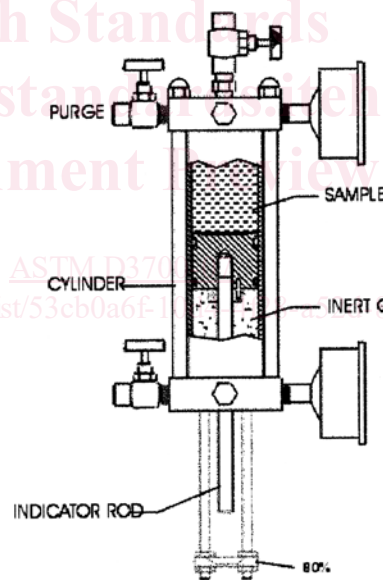

FIG. 1 Typical Floating Piston Cylinders

maintain sample integrity for the tests being performed. A typical sampling system for LPG flowing in a pipe is shown in Fig. 2.

NOTE 6—While not required by this practice, the use of a sample probe in a flowing line is recommended. The sample probe should be located on the top or side of a line, extending into the center third of the flowing stream. Sample points should not be installed on the bottom of a line, unless provisions are made to flush any accumulated debris from the sample point immediately prior to sampling.

7.4.2 Transfer lines, valves, pressure gages and so forth in the transfer system shall be corrosion resistant and designed

consistent with maximum anticipated pressure (typically stainless steel). Experience has shown that the transfer lines should have a minimum internal diameter of 3 mm nominal (1/8 in.) and be as short as practical to minimize line blockage or sample vaporization, or both. The use of filters, dryers, needle valves and so forth are not recommended, unless provisions are made to prevent excessive flow restriction and pressure drop. A T junction with a purge valve at the sample connection point is recommended to allow purging of the dead volume at the

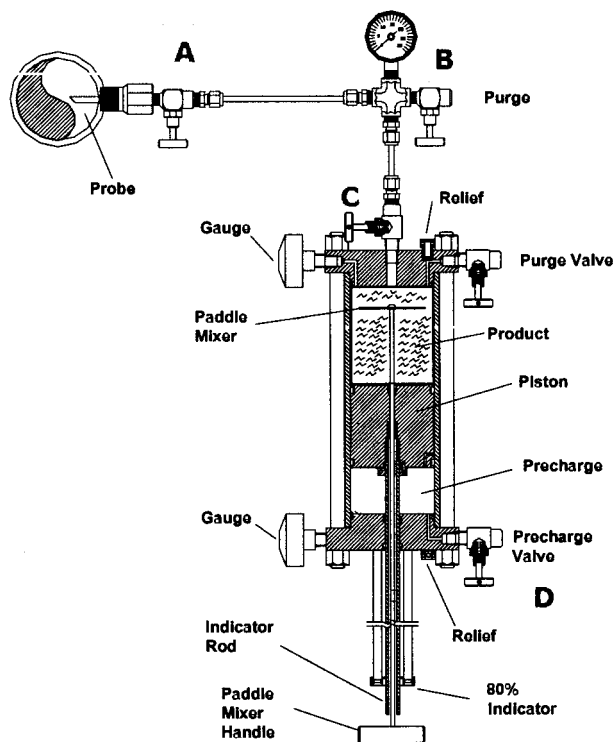

FIG. 2 Typical Sampling System

sampler connection. Flexible hose or tubing with adequate pressure rating may be used.

NOTE 7—While not required by this practice, the use of non-reactive and non-absorptive materials is recommended, especially when sampling to determine trace levels of reactive or polar materials such as H₂S and water.

7.4.3 Other piping arrangements may be acceptable, but may require different flushing procedures prior to sample collection. Typical sample loops are shown in Figs. 3 and 4.

7.4.4 Closed loop side stream samplers designed to minimize volatile light end losses during sampling may be used. The sample system shall be connected to on-line analysers or composite samplers in a manner that ensures sample integrity is maintained for the tests being performed.

7.4.5 Sample loops should preferably be installed around pumps, valves, or other sources of pressure drop to minimize atmospheric emissions from purging of sample lines.

7.4.6 Sampling pumps or other means of controlling pressures higher than the vapor pressure of the sample may be acceptable, and may be used to flush both the lines and/or the cylinder dead volume, if any, prior to sample collection. The cylinder may be partially filled and then emptied prior to collection of the sample as an alternative to venting hydrocarbon to flush lines.

7.5 Composite Sampler:

7.5.1 A composite sampler (also called a proportional sampler) is a device that is used to obtain a representative sample from a flowing product stream by accumulating small portions of product over a period of time. The sampling system consists of a sample probe, a means of collecting repetitive small portions, and a floating piston cylinder to accumulate the total

sample. Figs. 5 and 6 show typical sample systems using a probe-mounted sample pump (Fig. 5), or a flow-through sample injection valve (Fig. 6).

7.5.2 Thorough purging of sample lines, pumps, and connections to the sample cylinder is necessary to avoid contamination of the sample. A suitable purging arrangement at the point of sampling shall be provided. This purging arrangement may take the form of a T connection and purging valve, or an operating procedure that allows slight loosening of the connection to vent the dead volume at the sample connection (if allowed by the local jurisdiction). Composite sampler systems shall be designed to minimize dead end lines that could result in the sample not being representative of the LPG source.

7.5.3 Take precautions to avoid vaporization in sample loop lines when operating near the equilibrium vapor pressure of the LPG. In some instances, it may be necessary either to cool or insulate the sample line and sample container, or to control the pressure or temperature of sample containers.

7.5.4 Ensure that the pressure at the sample point is above the vapor pressure of the sample to avoid vaporization in the pipe or sampling lines when using a device such as an orifice plate or valve to create a pressure differential for sampling.

7.5.5 The floating piston cylinder shall be connected to the purged sample line of the composite sampler. Apply inert gas pressure to the cylinder to force the piston to the sample point end of the FPC. Maintain the inert gas pressure at a pressure that exceeds the equilibrium vapor pressure of the fluid sampled under the expected temperature conditions by about 350 to 1400 kPa (50 to 200 psi). At pressure differences less than about 1400 kPa (200 psi), there is an increasing chance of

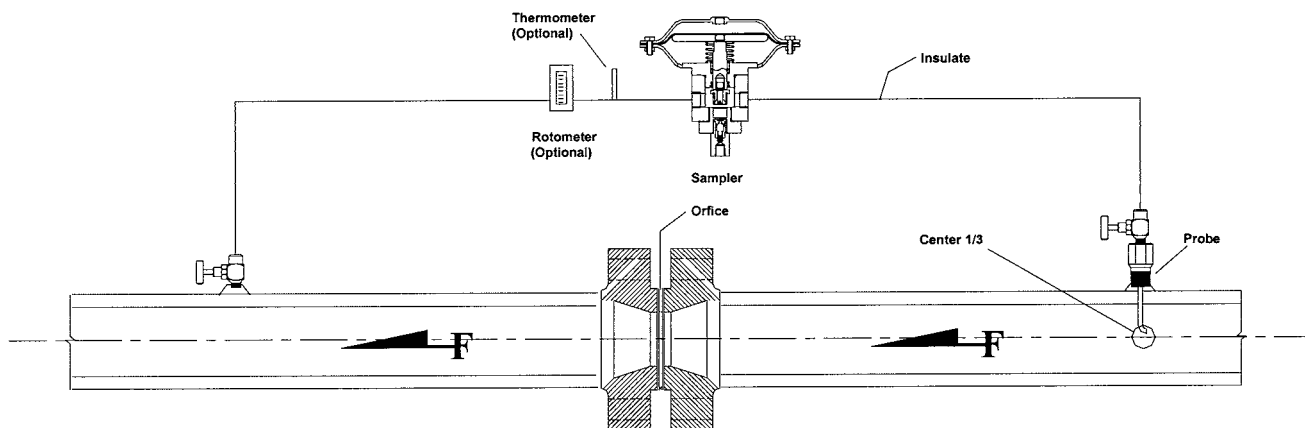

FIG. 3 Typical Sample Probe Installation on Orifice Fitting

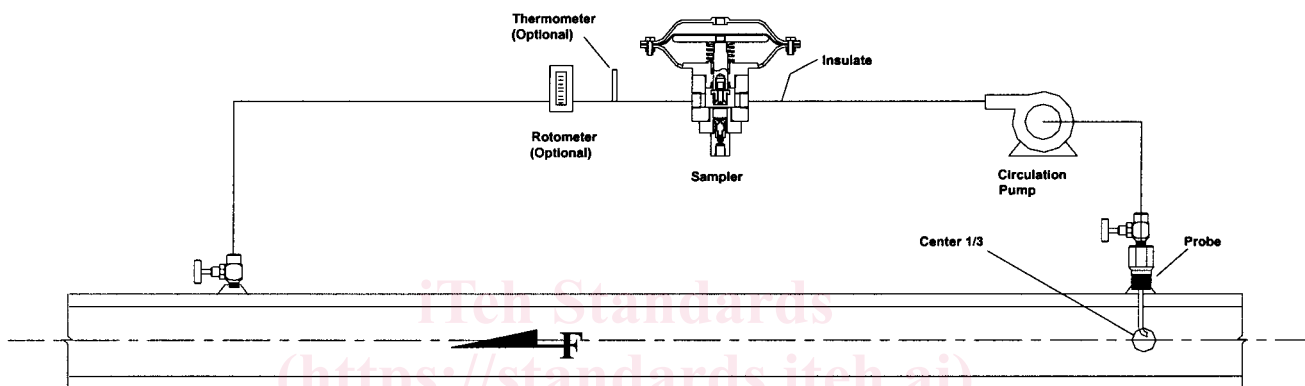

FIG. 4 Typical Sample Probe Installation for a Pump

non-representative samples. Transient pressure fluctuation below the vapor pressure can result in non-representative samples.

7.5.6 Adjust the automatic sample injection valve to obtain incremental samples at a rate such that the floating piston cylinder will have adequate capacity to hold the sample during its period of sampling. Set the sampling rate to prevent overfilling of the sample container, considering the maximum anticipated flow rates and time periods. A liquid filled cylinder may not have a representative sample, since sampling may have stopped prior to the end of the sampling period, or preferential release of light ends (depending upon venting configuration).

7.5.7 Adjust the total volume taken over the sampling period in proportion to the flow rate of the product by adjusting each incremental sample volume taken by the sampling valve, or adjusting the frequency of incremental samples, or both.

7.5.8 The floating piston cylinder used in the above system may be removed from the composite sampling device after the desired sample has been collected.

7.5.9 Do not take outage or reduce pressure on the cylinder. Check valves for leaks, cap valves to protect threads, and prepare sample information tag and box for transport according to the Department of Transportation or other applicable requirements.

7.5.10 If it is not possible to disconnect the primary floating piston cylinder from the automatic system, mix the sample in

the primary cylinder to homogenize it and transfer sample to a secondary floating piston cylinder. Proceed as in 9.2.1, treating the primary cylinder as a flowing source. In this particular transfer situation, as sample is withdrawn, the master sample container will partially depressurize. Maintain the pre-charge pressure above the product vapor pressure at the existing master sampler temperature to prevent flashing. (**Warning**—The cylinder must not be filled beyond 80 % of its capacity with sample. In the event of an inadvertent over fill, sample must be vented out to the required reduced fill density (typically 80 %) prior to transport. See 7.1.2 for further guidance. Where immediate venting is not possible; for example, inside hazardous locations or with toxic materials (especially H₂S), provisions shall be made to prevent temperature increase prior to venting in a safe location, transfer to a larger cylinder or perform an immediate analysis then vent the sample or complete an alternate disposition in accordance with the jurisdiction having authority. It is the responsibility of the user to establish safe procedures for use in permitted facilities that are not regulated by site permits or equivalent, separate from transportation regulations.)

7.5.11 Transfer and venting operations require careful control to maintain the cylinder pressure well above the vapor pressure of the well mixed sample to prevent changes in sample composition from *flashing* of the contents.

7.5.12 *Sample Filters*—The sample filter is an optional device used to protect the sampling valve from scoring due to

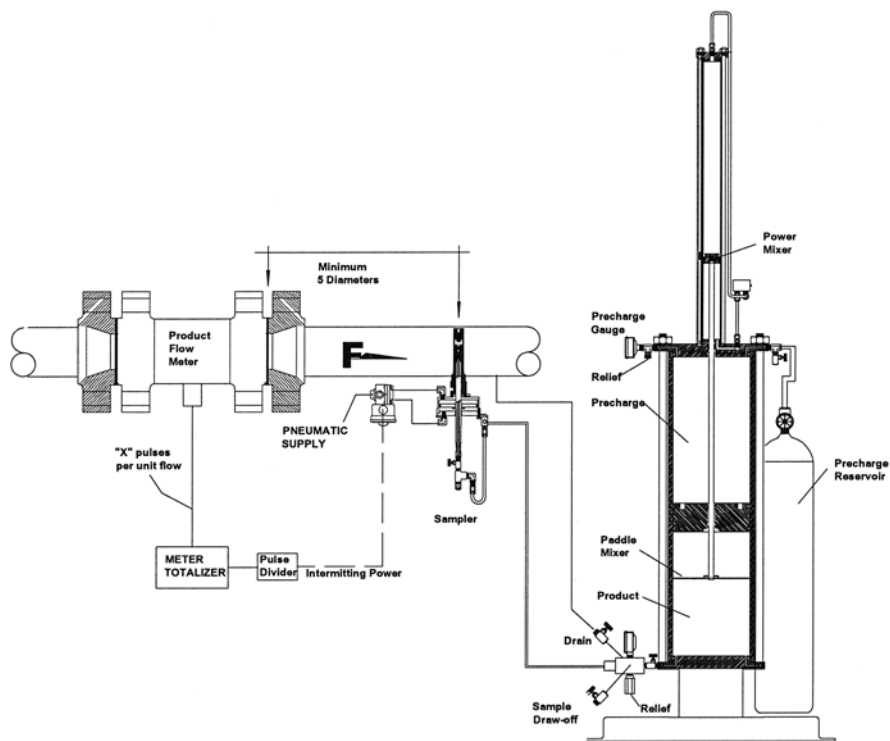

FIG. 5 Typical Sampler Using an Injection Pump

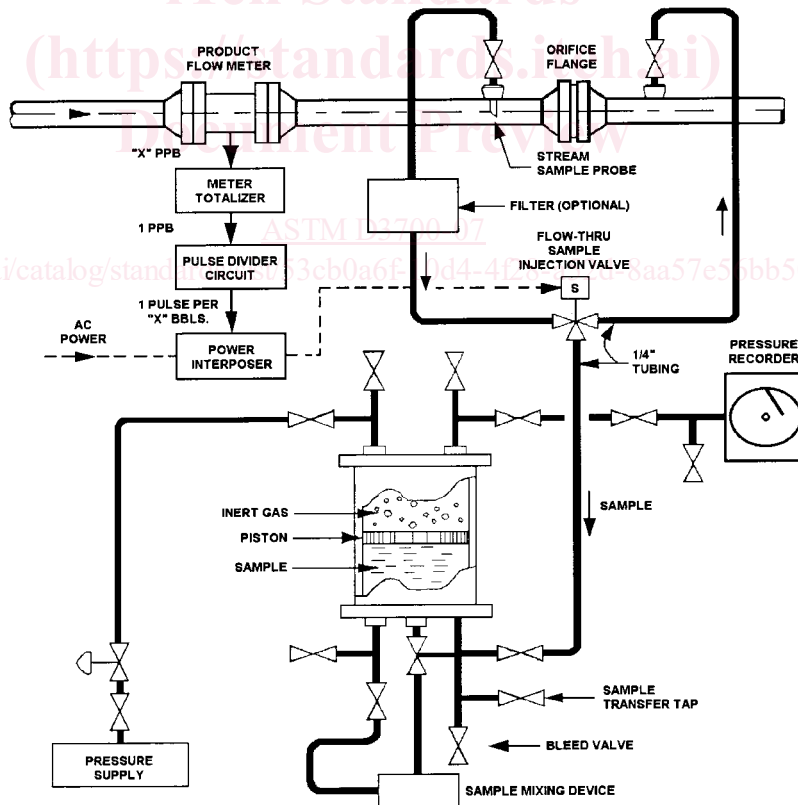

FIG. 6 Typical Automatic Proportional Sampler

the presence of foreign contaminants such as metal shavings, dirt, and so forth. The filter should be of a small total volume,

of an inline-type design, and contain a replaceable/disposable element. (**Warning**—Be aware that using filters or strainers