

---

---

**Textiles — Test method for assessing the  
smoothness appearance of fabrics after  
cleansing**

*Textiles — Méthode d'essai pour l'évaluation de la régularité d'aspect  
des étoffes après nettoyage*

**iTeh STANDARD PREVIEW**  
**(standards.iteh.ai)**

[ISO 7768:2009](#)

<https://standards.iteh.ai/catalog/standards/sist/c3b8164e-2771-4e76-b59c-9da22d99136a/iso-7768-2009>



**PDF disclaimer**

This PDF file may contain embedded typefaces. In accordance with Adobe's licensing policy, this file may be printed or viewed but shall not be edited unless the typefaces which are embedded are licensed to and installed on the computer performing the editing. In downloading this file, parties accept therein the responsibility of not infringing Adobe's licensing policy. The ISO Central Secretariat accepts no liability in this area.

Adobe is a trademark of Adobe Systems Incorporated.

Details of the software products used to create this PDF file can be found in the General Info relative to the file; the PDF-creation parameters were optimized for printing. Every care has been taken to ensure that the file is suitable for use by ISO member bodies. In the unlikely event that a problem relating to it is found, please inform the Central Secretariat at the address given below.

**iTeh STANDARD PREVIEW**  
**(standards.iteh.ai)**

ISO 7768:2009

<https://standards.iteh.ai/catalog/standards/sist/c3b8164e-2771-4e76-b59c-9da22d99136a/iso-7768-2009>



**COPYRIGHT PROTECTED DOCUMENT**

© ISO 2009

All rights reserved. Unless otherwise specified, no part of this publication may be reproduced or utilized in any form or by any means, electronic or mechanical, including photocopying and microfilm, without permission in writing from either ISO at the address below or ISO's member body in the country of the requester.

ISO copyright office  
Case postale 56 • CH-1211 Geneva 20  
Tel. + 41 22 749 01 11  
Fax + 41 22 749 09 47  
E-mail [copyright@iso.org](mailto:copyright@iso.org)  
Web [www.iso.org](http://www.iso.org)

Published in Switzerland

**Contents**

Page

<b>Foreword</b> .....	<b>iv</b>
<b>1 Scope</b> .....	<b>1</b>
<b>2 Normative references</b> .....	<b>1</b>
<b>3 Principle</b> .....	<b>1</b>
<b>4 Apparatus</b> .....	<b>1</b>
<b>5 Test specimens</b> .....	<b>3</b>
<b>6 Procedure</b> .....	<b>3</b>
<b>7 Expression of results</b> .....	<b>4</b>
<b>8 Test report</b> .....	<b>4</b>
<b>Annex A (informative) Precision and accuracy</b> .....	<b>6</b>
<b>Annex B (informative) Digital description of the ISO smoothness replicas</b> .....	<b>7</b>

**iTeh STANDARD PREVIEW**  
**(standards.iteh.ai)**

[ISO 7768:2009](#)

<https://standards.iteh.ai/catalog/standards/sist/c3b8164e-2771-4e76-b59c-9da22d99136a/iso-7768-2009>

## Foreword

ISO (the International Organization for Standardization) is a worldwide federation of national standards bodies (ISO member bodies). The work of preparing International Standards is normally carried out through ISO technical committees. Each member body interested in a subject for which a technical committee has been established has the right to be represented on that committee. International organizations, governmental and non-governmental, in liaison with ISO, also take part in the work. ISO collaborates closely with the International Electrotechnical Commission (IEC) on all matters of electrotechnical standardization.

International Standards are drafted in accordance with the rules given in the ISO/IEC Directives, Part 2.

The main task of technical committees is to prepare International Standards. Draft International Standards adopted by the technical committees are circulated to the member bodies for voting. Publication as an International Standard requires approval by at least 75 % of the member bodies casting a vote.

Attention is drawn to the possibility that some of the elements of this document may be the subject of patent rights. ISO shall not be held responsible for identifying any or all such patent rights.

ISO 7768 was prepared by Technical Committee ISO/TC 38, *Textiles*, Subcommittee SC 2, *Cleansing, finishing and water resistance tests*.

This third edition cancels and replaces the second edition (ISO 7768:2006), of which it constitutes a minor revision. It incorporates ISO 7768:2006/DAmD.1:2008 to add Annex B (informative).

ISO 7768:2009  
<https://standards.iteh.ai/catalog/standards/sist/c3b8164e-2771-4e76-b59c-9da22d99136a/iso-7768-2009>

# Textiles — Test method for assessing the smoothness appearance of fabrics after cleansing

## 1 Scope

This International Standard specifies a method for assessing the retention of the original smooth appearance, after one or several cleansing treatments, of the fabrics tested.

This method has been developed for use primarily with Type B domestic washing machines, as defined in ISO 6330, in the cleansing process. However, it may be possible to use it with Type A machines, as defined in the same International Standard. This test method could be used for judging smoothness appearance after other cleansing processes.

NOTE It is recognized that prints and patterns will mask the mussiness present in fabrics. However, this does not detract from the smoothness appearance concept which seeks to provide the consumer with fabrics which require little or no ironing.

## iTeh STANDARD PREVIEW

## 2 Normative references (standards.iteh.ai)

The following referenced documents are indispensable for the application of this document. For dated references, only the edition cited applies. For undated references, the latest edition of the referenced document (including any amendments) applies.

ISO 105-A03, *Textiles — Tests for colour fastness — Part A03: Grey scale for assessing staining*

ISO 139, *Textiles — Standard atmospheres for conditioning and testing*

ISO 3175 (all parts), *Textiles — Professional care, drycleaning and wetcleaning of fabrics and garments*

ISO 6330, *Textiles — Domestic washing and drying procedures for textile testing*

## 3 Principle

Fabric specimens are subjected to procedures simulating cleansing practices. One of the domestic washing and drying procedures specified in ISO 6330 or one of the professional procedures specified in the series of ISO 3175 is used, as agreed between the interested parties.

## 4 Apparatus

**4.1 Washing and drying apparatus**, as specified in ISO 6330, or **professional care apparatus**, as specified in ISO 3175.

### 4.2 Lighting.

The evaluation area shall be a darkened room, using the overhead lighting arrangement shown in Figure 1 and comprising the following items. Lamp dimensions should be chosen to extend beyond the overall surface of a test specimen and replicas, when used for the assessment.

4.2.1 Two CW (cool white) fluorescent lamps, without baffle or glass, a minimum of 2 m in length each, placed side by side.

4.2.2 One white enamel reflector, without baffle or glass.

4.2.3 One specimen holder.

4.2.4 One thick plywood viewing board, painted grey to match the No. 2 rating on the grey scale for assessing staining specified in ISO 105-A03.

4.3 Three-dimensional smoothness appearance replicas (see Figure 2) <sup>1)</sup>.

NOTE A digital description of the ISO smoothness replicas is given in Annex B.

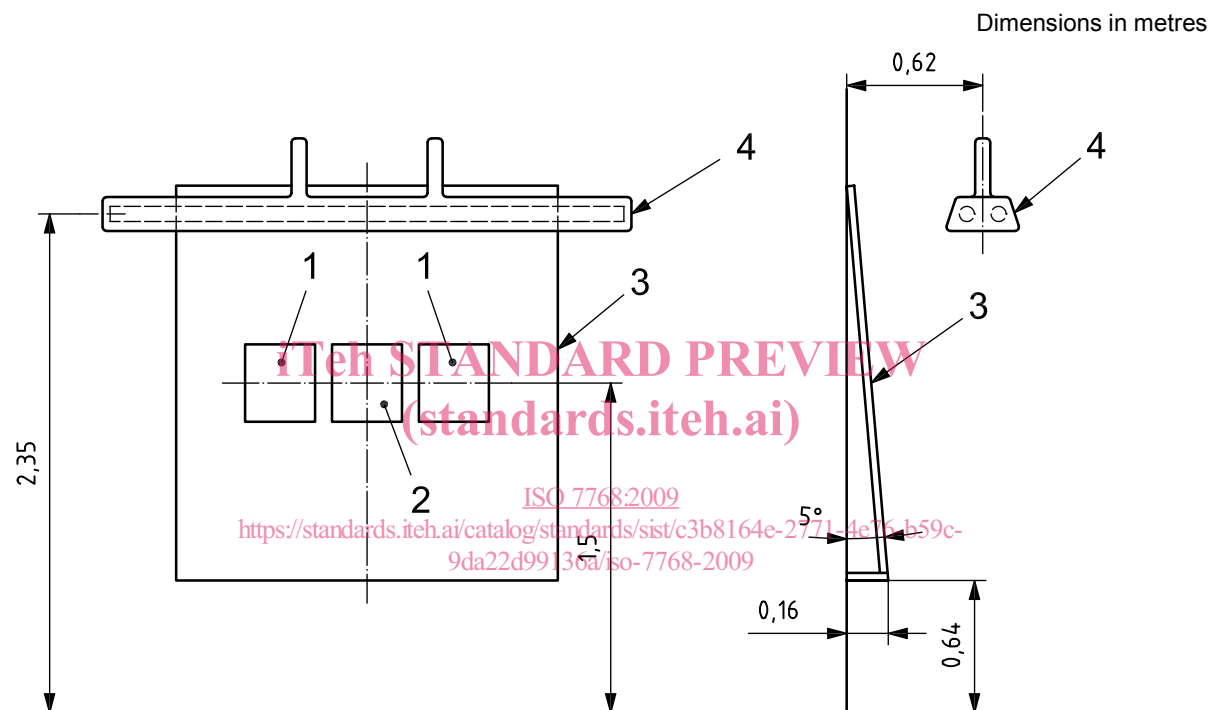

**Key**

- 1 replica
- 2 test specimen
- 3 board for viewing
- 4 example of fluorescent lamp placement

**Figure 1 — Lighting equipment for viewing test specimens**

1) The replicas shown in Figure 2 are for illustrative purposes only. These replicas may be obtained from AATCC Technical Center, One Davis Drive, P.O. Box 12215, Research Triangle Park, North Carolina 27709-2215 USA; Tel: +1 919-549-8141; Fax: +1 919-549-8933; <http://www.aatcc.org>. This information is given for the convenience of users of this document and does not constitute an endorsement by ISO of the product named. Equivalent products may be used if they can be shown to lead to the same results.



Figure 2 — Three-dimensional smoothness appearance replicas

## 5 Test specimens

Prepare three test specimens, each measuring 38 cm × 38 cm, cut parallel to the length direction, pinked to prevent fraying and marked to indicate the length direction.

## 6 Procedure

**6.1** Treat each specimen according to one of the cleansing procedures specified in ISO 6330 or ISO 3175, as agreed between the interested parties.

**6.2** If required, repeat the selected treatment four times, to give a total of five cycles.

**6.3** Condition the test specimens for a minimum of 4 h and maximum of 24 h, according to ISO 139, by hanging each specimen unfolded with the length direction vertical to avoid distortion.

**6.4** For the evaluation, carry out steps 6.4.1 to 6.4.5.

**6.4.1** Three observers shall rate each treated test specimen independently.

**6.4.2** Mount the test specimen on the viewing board (4.2.4) as illustrated in Figure 1, with the length direction vertical. Place the three-dimensional plastic replicas (4.3) on each side of the test specimen to facilitate comparative rating.

The overhead fluorescent light (4.2.1) shall be the only light source for the viewing board, and all other lights in the room shall be turned off. It has been the experience of many observers that the light reflected from the side walls near the viewing board can interfere with the rating results. It is recommended that the side walls be painted black or that blackout curtains be mounted on either side of the viewing board to eliminate the reflective interference.

**6.4.3** The observer shall stand directly in front of the specimen, 1,2 m away from the board. It has been found that normal variations in the height of the observer above and below the arbitrary 1,5 m eye level have no significant effect on the rating given.

**6.4.4** Assign the number of the replica which most nearly matches the appearance of the test specimen, or assign ratings midway between those whole-number standards which have no half-number standards separating them if the appearance of the specimens warrants it (see Table 1).

An SA-5 rating is equivalent to the SA-5 replica and represents the smoothest appearance and best retention of original appearance, while an SA-1 rating is equivalent to the SA-1 replica and represents the poorest appearance and poorest retention of original appearance.

**6.4.5** Similarly, the observer shall independently rate each of the other two test specimens. The other two observers shall proceed in the same manner, assigning ratings independently.

**Table 1 — Fabric smoothness ratings**

Rating	Appearance
SA-5	Equivalent to the SA-5 replica
4,5	Midway between Standard SA-4 and SA-5
SA-4	Equivalent to the SA-4 replica
SA-3,5	Equivalent to the SA-3,5 replica
SA-3	Equivalent to the SA-3 replica
2,5	Midway between Standard SA-2 and SA-3
SA-2	Equivalent to the SA-2 replica
1,5	Midway between Standard SA-1 and SA-2
SA-1	Equivalent to or worse than the SA-1 replica

**7 Expression of results**

Average the nine observations made by the three observers on the set of three test specimens. Report the average to the nearest half rating.

NOTE Data on precision and accuracy are given in Annex A. Because the test procedure described is subjective and ordinal ratings are given, statistics that use frequency distribution as a basis were applied to the data.

**8 Test report**

The test report shall include the following information:

- a) a reference to this International Standard (ISO 7768:2009);
- b) details of the sample evaluated;
- c) details of the cleansing procedures used;



- d) the number of cleansing cycles used;
- e) the fabric smoothness rating as calculated according to Clause 7 and expressed according to Table 1;
- f) details of any deviation from the specified procedure.

**iTeh STANDARD PREVIEW**  
**(standards.iteh.ai)**

ISO 7768:2009

<https://standards.iteh.ai/catalog/standards/sist/c3b8164e-2771-4e76-b59c-9da22d99136a/iso-7768-2009>

## Annex A (informative)

### Precision and accuracy

Tests were conducted in the USA in 1980 with eight laboratories evaluating four fabrics. The analysis of variance technique was judged not to be applicable to these data because their distribution was not normal and because of the limited and discontinuous scale of replica ratings. The data were analysed by calculating expected laboratory test results from the distribution of individual specimen ratings.

From the data, it was determined that single observers rated three specimens on the following frequency:

- Three specimens to same replica: 0,55
- Two specimens to same replica and one different: 0,40
- Three specimens different: 0,05

Only rarely did the separation in specimen ratings exceed the next replica step. This is indicative of the high degree of repeatability in observer ratings.

From the observer rating distribution, a distribution of laboratory test results was calculated for each replica level with half-ratings included. Precision over the whole SA replica was improved.

From the frequency distribution of laboratory test results, a calculation was made of the critical difference,  $D$ , between two laboratory test levels. With laboratories at the same level:

Critical difference	Confidence level
$D > 0,17$	$P \geq 0,95$
$D \geq 0,25$	$P \geq 0,99$

When two or more laboratories wish to compare test results, it is recommended that laboratory levels be established between them prior to commencing test comparisons. Fabrics of known history and performance may be used for this purpose.

Differences between laboratory test results (on the same fabric, under the same washing and drying conditions) equal to or greater than a quarter replica unit are statistically significant at  $P$  greater than 0,99. A difference of this magnitude or greater suggests a difference in laboratory levels and indicates a need for laboratory level comparisons.

A true value of smoothness appearance of fabrics after repeated home launderings can be defined only in terms of a test method. There is no independent method for determining the true value. As an estimate of this property, this test has no known bias.

## Annex B (informative)

### Digital description of the ISO smoothness replicas

#### B.1 Introduction

This annex provides the digital description of 3D replicas. The data are not intended to be used to assess specimens. When assessing specimens, the 3D replicas are to be used.

#### B.2 Processes of measurement and analysis

**B.2.1** A 3-dimensional scanning system was used to measure digital images of ISO smoothness replicas as shown in Figure B.1. Specifications for the scanning system are shown in Table B.1.



**Figure B.1 — 3-Dimensional scanning system**

**Table B.1 — Specification of the 3-dimensional scanning system**

Camera	1 024 × 768 pixels, black and white (B/W)
Special pattern	Structural beam by halogen lamp
Adjustment of focus	Using the laser-point light source
Measurement time	Approximately 70 s to 80 s
Resolution	± 0,05 mm