



# SLOVENSKI STANDARD

## SIST EN 12965:2004

01-januar-2004

---

Traktorski stroji in oprema za kmetijstvo in gozdarstvo - Moč vzajemne osi (PTO) pogonske osi in njihova zaščita - Varnost

Tractors and machinery for agriculture and forestry - Power take-off (PTO) drive shafts and their guards - Safety

Traktoren und Maschinen für die Land- und Forstwirtschaft - Gelenkwellen und ihre Schutzeinrichtungen - Sicherheit

Tracteurs et matériels agricoles et forestiers - Arbres de transmission à cardans de prise de force et leurs protecteurs - Sécurité

<https://standards.iteh.ai/catalog/standards/sist/86b3ad8f-2a6c-47e9-8438-74320343c594/sist-en-12965-2004>

**Ta slovenski standard je istoveten z: EN 12965:2003**

---

**ICS:**

65.060.01	Kmetijski stroji in oprema na splošno	Agricultural machines and equipment in general
-----------	---------------------------------------	--

**SIST EN 12965:2004**

**en**

**iTeh STANDARD PREVIEW**  
**(standards.iteh.ai)**

[SIST EN 12965:2004](#)

<https://standards.iteh.ai/catalog/standards/sist/86b3ad8f-2a6c-47e9-8438-74320343c594/sist-en-12965-2004>

EUROPEAN STANDARD

EN 12965

NORME EUROPÉENNE

EUROPÄISCHE NORM

June 2003

ICS 65.060.01

English version

## Tractors and machinery for agriculture and forestry - Power take-off (PTO) drive shafts and their guards - Safety

Tracteurs et matériels agricoles et forestiers - Arbres de transmission à cardans de prise de force et leurs protecteurs - Sécurité

Traktoren und Maschinen für die Land- und Forstwirtschaft - Gelenkwellen und ihre Schutzeinrichtungen - Sicherheit

This European Standard was approved by CEN on 13 February 2003.

CEN members are bound to comply with the CEN/CENELEC Internal Regulations which stipulate the conditions for giving this European Standard the status of a national standard without any alteration. Up-to-date lists and bibliographical references concerning such national standards may be obtained on application to the Management Centre or to any CEN member.

This European Standard exists in three official versions (English, French, German). A version in any other language made by translation under the responsibility of a CEN member into its own language and notified to the Management Centre has the same status as the official versions.

CEN members are the national standards bodies of Austria, Belgium, Czech Republic, Denmark, Finland, France, Germany, Greece, Hungary, Iceland, Ireland, Italy, Luxembourg, Malta, Netherlands, Norway, Portugal, Slovakia, Spain, Sweden, Switzerland and United Kingdom.

[SIST EN 12965:2004](https://standards.iteh.ai/catalog/standards/sist/86b3ad8f-2a6c-47e9-8438-74320343c594/sist-en-12965-2004)

<https://standards.iteh.ai/catalog/standards/sist/86b3ad8f-2a6c-47e9-8438-74320343c594/sist-en-12965-2004>



EUROPEAN COMMITTEE FOR STANDARDIZATION  
COMITÉ EUROPÉEN DE NORMALISATION  
EUROPÄISCHES KOMITEE FÜR NORMUNG

Management Centre: rue de Stassart, 36 B-1050 Brussels

## Contents

	Page
Foreword.....	3
0 Introduction .....	4
1 Scope .....	4
2 Normative references .....	4
3 Terms and definitions.....	5
4 Requirements and/or safety measures.....	8
4.1 General requirements.....	8
4.2 Universal joint .....	8
4.3 Wide-angle universal joint .....	9
4.4 Guard.....	11
4.5 Intervention points.....	11
4.6 Restraining system.....	11
5 Verification of safety requirements and/or measures.....	11
5.1 General.....	11
5.2 Test for cone guarding the universal joints.....	11
6 Information for use .....	13
6.1 Instruction handbook .....	13
6.2 Marking and warning.....	15
Annex A (normative) List of hazards.....	16
Annex ZA (informative) Relationship of this document with EC Directives.....	20
Bibliography .....	21

iTeh STANDARD PREVIEW  
(standards.iteh.ai)

[SIST EN 12965:2004](https://standards.iteh.ai/catalog/standards/sist/86b3ad8f-2a6c-47e9-8438-74320343c594/sist-en-12965-2004)

<https://standards.iteh.ai/catalog/standards/sist/86b3ad8f-2a6c-47e9-8438-74320343c594/sist-en-12965-2004>

## Foreword

This document (EN 12965:2003) has been prepared by Technical Committee CEN/TC 144, "Tractors and machinery for agriculture and forestry", the secretariat of which is held by AFNOR.

This European Standard shall be given the status of a national standard, either by publication of an identical text or by endorsement, at the latest by December 2003, and conflicting national standards shall be withdrawn at the latest by December 2003.

This document has been prepared under a mandate given to CEN by the European Commission and the European Free Trade Association, and supports essential requirements of EC Directive(s).

For relationship with EC Directive(s), see informative annex ZA, which is an integral part of this document.

EN 1152:1994 "*Tractors and machinery for agriculture and forestry — Guards for power take-off (PTO) drive shafts — Wear and strength tests*" complements this European Standard which gives definitions and requirements concerning PTO drive shafts and their guards.

Annex A is normative.

**iTeh STANDARD PREVIEW**

This document includes a Bibliography. ([standards.iteh.ai](https://standards.iteh.ai))

According to the CEN/CENELEC Internal Regulations, the national standards organizations of the following countries are bound to implement this European Standard: Austria, Belgium, Czech Republic, Denmark, Finland, France, Germany, Greece, Hungary, Iceland, Ireland, Italy, Luxembourg, Malta, Netherlands, Norway, Portugal, Slovakia, Spain, Sweden, Switzerland and the United Kingdom.

## 0 Introduction

This European Standard is a type C standard as defined in EN 1070.

The machinery concerned and the extent to which hazards, hazardous situations and events are covered are indicated in the scope of this document.

When provisions of this type C standard are different from those which are stated in type A or B standards, the provisions of this type C standard take precedence over the provisions of the other standards, for machines that have been designed and built according to the provisions of this type C standard.

The hazards that are common to agricultural machines (self-propelled, mounted, semi-mounted and trailed) are dealt with in EN 1553.

## 1 Scope

This standard specifies safety requirements and their verification for the design and construction of power take-off (PTO) drive shafts and their guards linking self-propelled machinery (or tractor) to the first fixed bearing of recipient machinery, by describing methods for the elimination or reduction of risks which need specific requirements. This standard concerns only the PTO drive shafts and those guards which are mechanically linked to the PTO drive shaft by at least two bearings.

In addition, it specifies the type of information on safe working practices to be provided by the manufacturer.

This standard does not deal with:

- the guards totally covering, but not mechanically linked to, the PTO drive shaft. As these devices are not at present widely established on the market, they should be dealt with in a future revision of this standard;
- the mechanical characteristics of PTO drive shafts, overrun devices and torque limiters;
- general hazards which are dealt with in EN 1553 (see introduction).

Environmental aspects have not been considered in this standard.

This document is not applicable to PTO drive shafts and their guards which are manufactured before the date of publication of this document by CEN.

## 2 Normative references

This European Standard incorporates by dated or undated reference, provisions from other publications. These normative references are cited at the appropriate places in the text, and the publications are listed hereafter. For dated references, subsequent amendments to or revisions of any of these publications apply to this European Standard only when incorporated in it by amendment or revision. For undated references the latest edition of the publication referred to applies (including amendments).

EN 292-1:1991, *Safety of machinery – Basic concepts, general principles for design – Part 1: Basic terminology, methodology.*

EN 292-2:1991, *Safety of machinery – Basic concepts, general principles for design – Part 2 : Technical principles and specifications (including amendment A1:1995).*

EN 294:1992, *Safety of machinery – Safety distance to prevent danger zones being reached by the upper limbs.*

EN 1070: 1998, *Safety of machinery – Terminology.*

EN 1152, *Tractors and machinery for agriculture and forestry – Guards for power take-off (PTO) drive shafts – Wear and strength tests.*

ISO 5673:1993, *Agricultural tractors and machinery – Power take-off drive shafts and position of power-input connection.*

ISO 11684:1995, *Tractors, machinery for agriculture and forestry, powered lawn and garden equipment – Safety signs and hazard pictorials – General principles.*

### 3 Terms and definitions

For the purposes of this European Standard, the terms and definitions given in EN 1070:1998 and ISO 5673:1993 and the following apply.

#### 3.1

##### **restraining system**

part of the PTO drive shaft guard which prevents rotation of the guard when the PTO drive shaft rotates

NOTE See Figure 1a [14] - only shown as an example.

#### 3.2

##### **wide-angle universal joint**

constant-velocity joint allowing operation with an articulation generally higher than 50°

NOTE See Figure 1b [9] - only shown as an example.

#### 3.3

##### **overrun device**

device that permits the transmission of motion only in one direction (from the tractor towards the recipient machinery). See Figure 2 <https://standards.iteh.ai/catalog/standards/sist/86b3ad8f-2a6c-47e9-8438-74320343c594/sist-en-12965-2004>

NOTE It is normally used with recipient machine having high value inertia.

#### 3.4

##### **torque limiter**

device that cuts or limits the transmission of motion between tractor and recipient machinery, when the torque reaches a prefixed value. See Figure 3

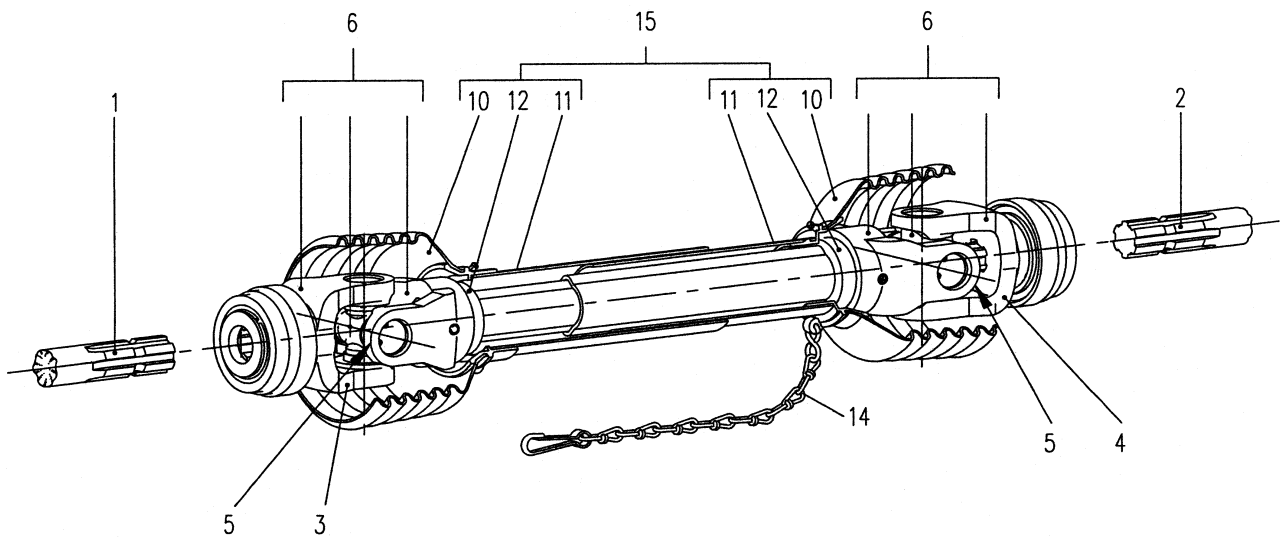

Figure 1a

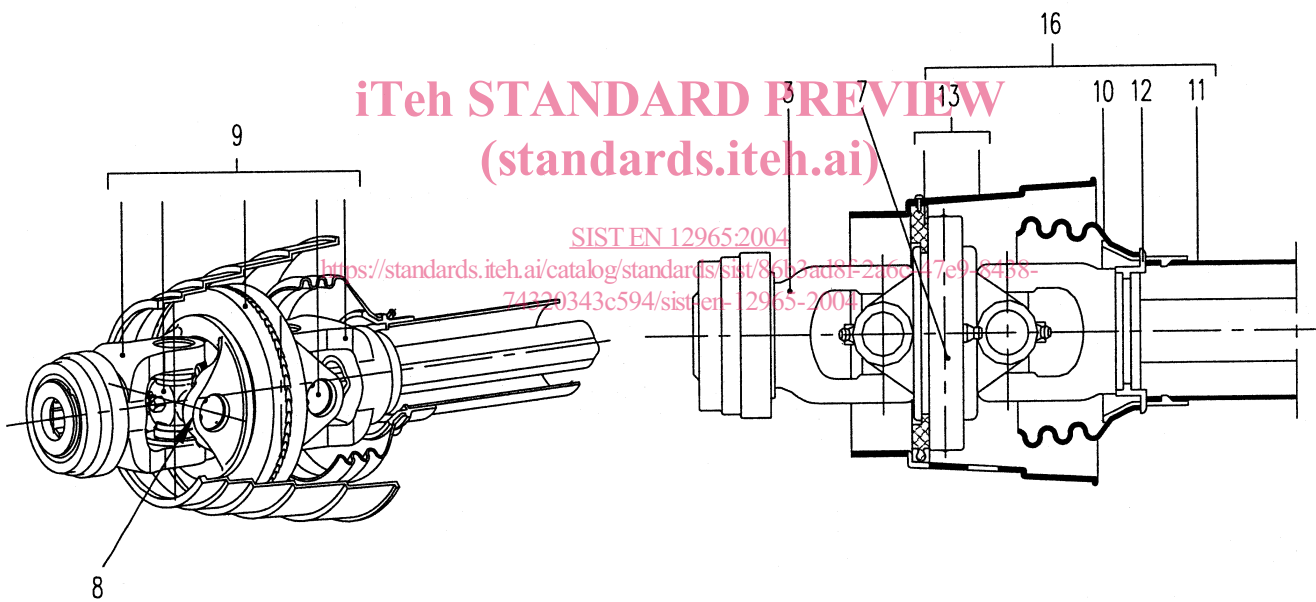

Figure 1b

**Key**

- |  |   |
|--|---|
| 1 Power take-off (PTO)                 | 10 Guard cone                                   |
| 2 Power-input connection (PIC)         | 11 Guard tube                                   |
| 3 PTO yoke                             | 12 Guard bearing                                |
| 4 PIC yoke                             | 13 Separate guard of wide angle universal joint |
| 5 End of inner yoke of universal joint | 14 Restraining system                           |
| 6 Universal joint                      | 15 PTO drive shaft guard                        |
| 7 Double yoke                          | 16 PTO wide-angle drive shaft guard             |
| 8 End of double yoke of outer joint    |   |
| 9 Wide-angle universal joint           |   |

Figure 1 — Parts of drive shaft and guard



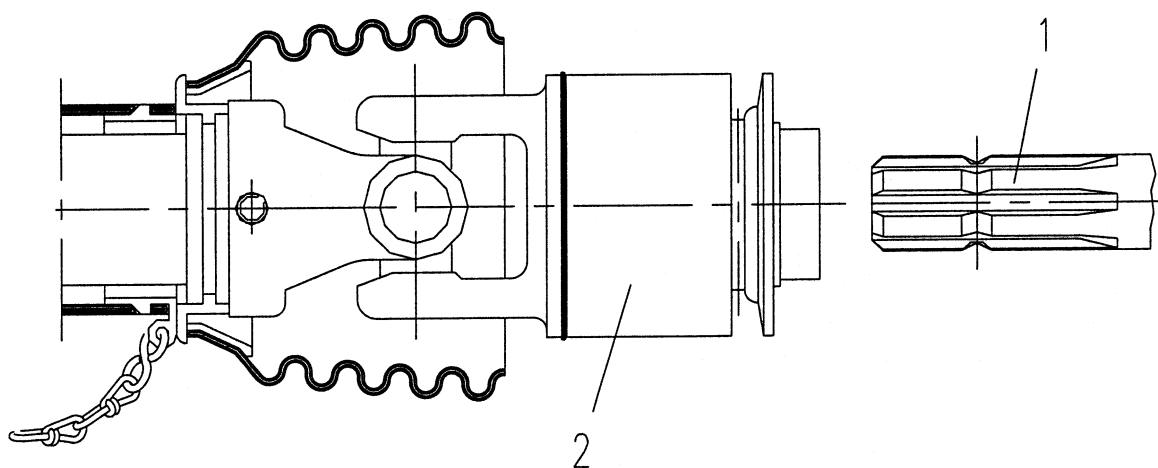

**Key**

- 1 PIC
- 2 Overrun device

**Figure 2 — Example of overrun device**  
 iTeh STANDARD PREVIEW  
 (standards.iteh.ai)

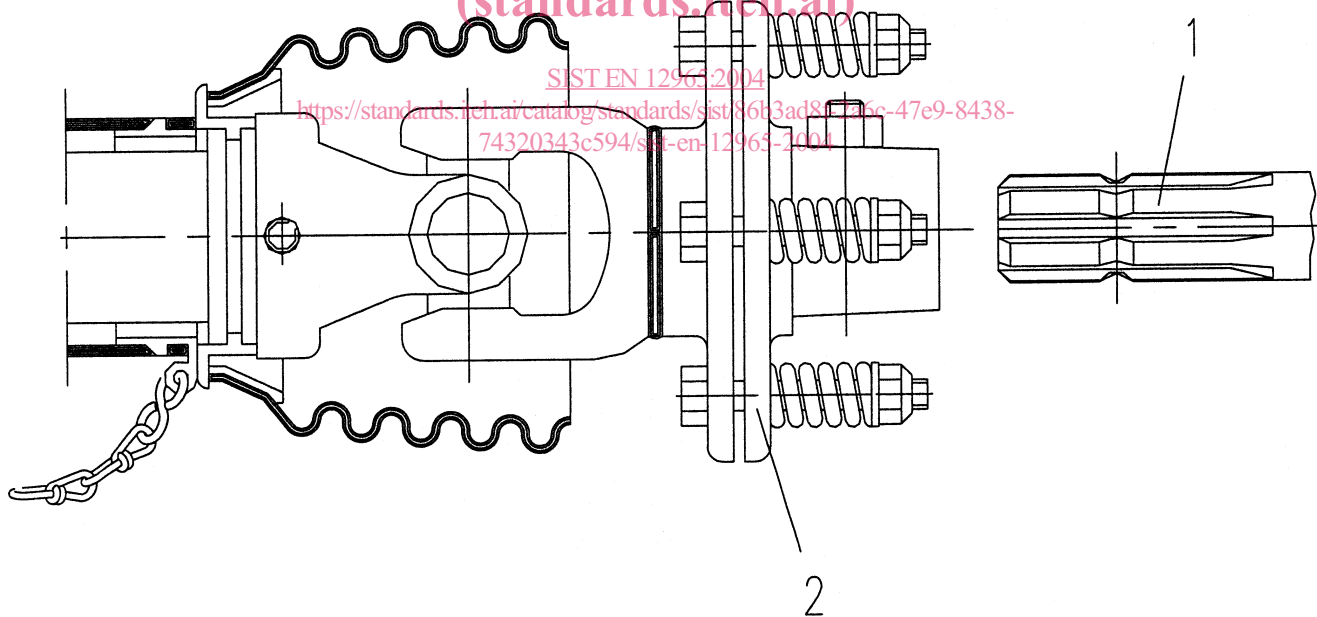

**Key**

- 1 PIC
- 2 Torque limiter

**Figure 3 — Example of torque limiter**

## 4 Requirements and/or safety measures

### 4.1 General requirements

The PTO drive shafts and their guards shall comply with the safety requirements and/or protective measures of this clause. In addition, the machine shall be designed according to the principles of EN 292 for hazards relevant but not significant, which are not dealt with by this standard (e.g. thermal hazards).

The list of significant hazards dealt with in this standard is given in annex A. Annex A also indicates the hazards which have not been dealt with.

The manufacturer shall provide data in the instruction handbook (see 6.1) defining the limiting use that can be made of the drive shaft and its guards. This shall include operating data and warnings against misuse (see 6.2).

The guard shall be designed to prevent contact with the moving components of the drive shaft whilst the drive shaft being operated in accordance with the instruction handbook and whilst the drive shaft being connected in the appropriate way between a tractor or self-propelled machine and a recipient machine.

The outside parts of the guard shall not turn with the transmission shaft.

The guard shall comply with acceptance criteria of EN 1152.

The locking system of the PTO yoke (see Figure 1a and Figure 1b) shall have no point which can cause entanglement (e.g. by collar design).

If there is a torque limiter and/or an overrun device on the drive shaft it shall be positioned only on the PIC side of the drive shaft as shown in Figures 2 and 3. Relevant marking shall be provided.

Unless otherwise specified in this standard, all the apertures and safety distances shall comply with the requirements of Tables 1, 3, 4 and 6 of EN 294:1992.

Warnings shall be provided on the guards specifying the necessity to read the instruction handbook.

### 4.2 Universal joint

The guard shall cover the drive shaft at least up to the end of the inner yoke of the universal joint (see Figure 1a and Table 1 for dimension *c* in Figure 4).

**Table 1 — Maximum distance between the end of the PTO drive shaft guard and the axis of the locking device**

Dimensions in millimetres

PTO type	<i>c</i> (maximum)
1	73
2	61
3	88

NOTE Dimension *c* is under study by CEN/TC 144/WG 1.

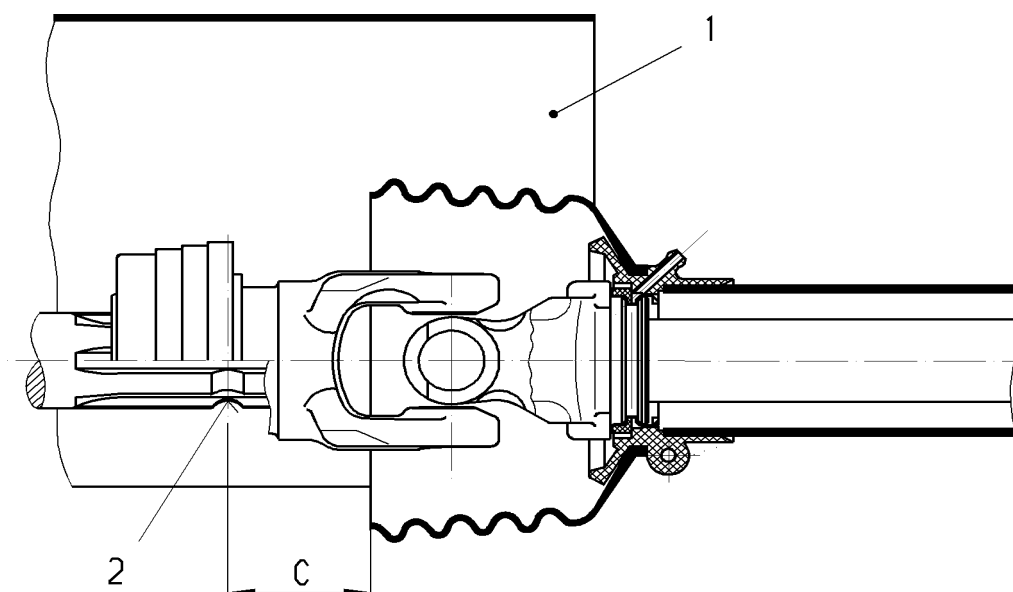
**Key**

- 1 Master shield of tractor power take-off (PTO)
- 2 Axis of locking device

**Figure 4 — Guarding of universal joints on PTO drive shafts on tractor side (side view).**  
 iTeh STANDARD PREVIEW  
 (standards.iteh.ai)

**4.3 Wide-angle universal joint**

The drive shaft shall be guarded in the straight-line position at least up to the end of the outer joint of the double yoke (see Figure 1b and Table 1 dimension *c* in Figure 5).  
 SIST EN 12965:2004  
 7320343094322-en-12965-2004

Dimensions in millimetres

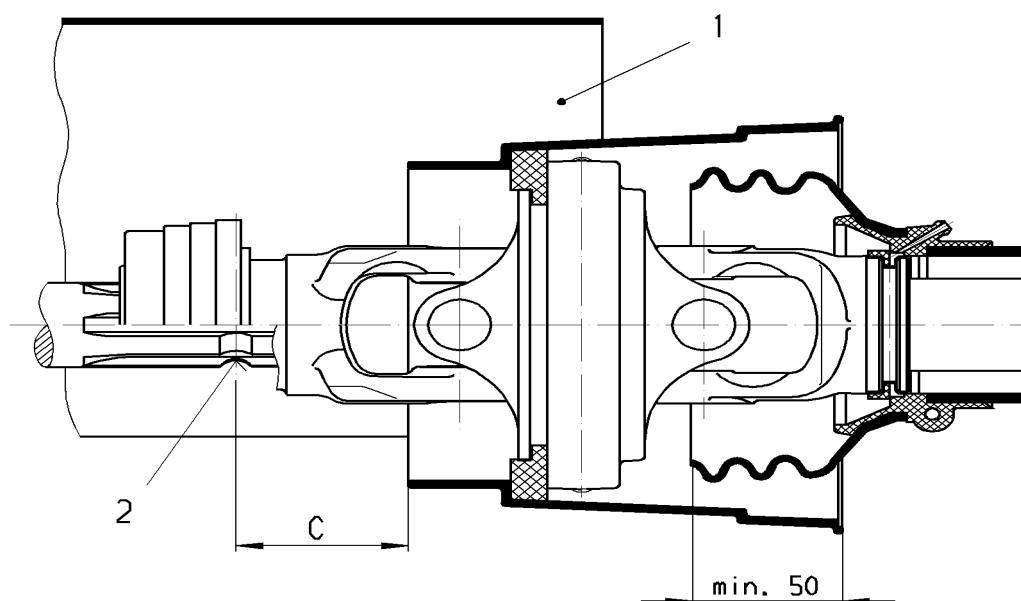
**Key**

- 1 Master shield of tractor power take-off (PTO)
- 2 Axis of locking device

**Figure 5 — Guarding of joints**