



Designation: D 4093 – 95 (Reapproved 2001)^{e1}

Standard Test Method for Photoelastic Measurements of Birefringence and Residual Strains in Transparent or Translucent Plastic Materials¹

This standard is issued under the fixed designation D 4093; the number immediately following the designation indicates the year of original adoption or, in the case of revision, the year of last revision. A number in parentheses indicates the year of last reapproval. A superscript epsilon (ϵ) indicates an editorial change since the last revision or reapproval.

^{e1} NOTE—Symbol in X3.1 was changed editorially. Also, certain equations were re-formatted throughout the standard in December 2001.

INTRODUCTION

Light propagates in transparent materials at a speed, v , that is lower than its speed in vacuum, c . In isotropic unstrained materials the index of refraction, $n = c/v$, is independent of the orientation of the plane of vibration of light. Transparent materials, when strained, become optically anisotropic and the index of refraction becomes directional. The change in index of refraction is related to strains. If n_o is the refractive index of unstrained material, the three principal indices of refraction, n_i , become linear functions of strain:

$$n_i - n_o = \sum A_{ij} \epsilon_j$$

Using photoelastic techniques (initially developed to measure stresses in transparent models) strains in plastics can be assessed. In isotropic materials, two material constants, A and B , are sufficient to describe their optomechanical behavior:

$$A_{ij} = A \text{ when } i = j, \text{ and} \\ A_{ij} = B \text{ when } i \neq j.$$

When light propagates through a region (where principal strains ϵ_1 and ϵ_2 are contained in the plane perpendicular to the direction of light propagation (see Fig. 1), the incoming vibration splits into two waves vibrating in planes of ϵ_1 and ϵ_2 . The difference between the indexes of refraction $n_1 = c/v_1$ and $n_2 = c/v_2$ (or birefringence) is:

$$n_1 - n_2 = (A - B)(\epsilon_1 - \epsilon_2) = k(\epsilon_1 - \epsilon_2)$$

where k is a material property called the strain-optical constant. As a result of their velocity difference, the waves vibrating along the two principal planes will emerge out of phase, their relative distance, or retardation, δ , given by:

$$\delta = (n_1 - n_2)t = k(\epsilon_1 - \epsilon_2)t$$

where t is the thickness of material crossed by the light. A similar equation, relating δ to the difference of principal stresses, σ_1 and σ_2 , can be written:

$$\delta = (n_1 - n_2)t = C(\sigma_1 - \sigma_2)t$$

The objective of photoelastic investigation is to measure: (a) the azimuth, or direction of principal strains, ϵ_1 and ϵ_2 (or stresses σ_1 and σ_2), and (b) the retardation, δ , used to determine the magnitude of strains. A complete theory of photoelastic effect can be found in the abundant literature on the subject (an extensive bibliography is provided in Appendix X2).

1. Scope

1.1 This test method covers measurements of direction of principal strains, ϵ_1 and ϵ_2 , and the photoelastic retardation, δ ,

using a compensator, for the purpose of analyzing strains in transparent or translucent plastic materials. The test method can be used to determine the difference of principal strains or normal strains when the principal directions do not change substantially within the light path.

1.2 In addition to the method using a compensator described in this test method, other methods are in use, such as the goniometric method (using rotation of the analyzer) mostly

¹ This test method is under the jurisdiction of ASTM Committee D20 on Plastics and is the direct responsibility of Subcommittee D20.10 on Mechanical Properties. Current edition approved Oct. 10, 1995. Published December 1995. Originally published as D 4093 – 82. Last previous edition D 4093 – 93.

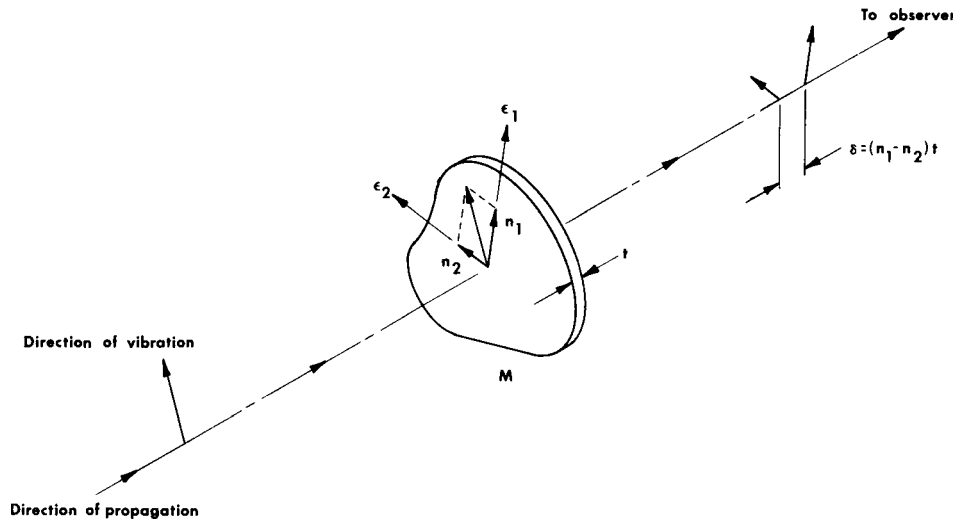

FIG. 1 Propagation of Light to a Strained Transparent Material

applied for measuring small retardation, and expressing it as a fraction of a wavelength. Nonvisual methods employing photoelectric conversion and eliminating the human judgement factor are also possible.

1.3 Test data obtained by this test method is relevant and appropriate for use in engineering design.

1.4 This standard does not purport to address all of the safety concerns, if any, associated with its use. It is the responsibility of the user of this standard to establish appropriate safety and health practices and determine the applicability of regulatory limitations prior to use.

2. Referenced Documents

2.1 ASTM Standards:

- D 618 Practice for Conditioning Plastics and Electrical Insulating Materials for Testing²
- D 638 Test Method for Tensile Properties of Plastics²
- D 882 Test Methods for Tensile Properties of Thin Plastic Sheeting²
- D 4000 Classification System for Specifying Plastic Materials³
- E 691 Practice for Conducting an Interlaboratory Study to Determine the Precision of a Test Method⁴

3. Terminology

3.1 Definitions:

3.1.1 *compensator*—an optical device used to measure retardation in transparent birefringent materials.

3.1.2 *polarizer*—polarizing element transmitting light vibrating in one plane only.

3.1.3 *quarter-wave plate*—a transparent filter providing a relative retardation of ¼ wavelength throughout the transmitting area.

3.2 Definitions of Terms Specific to This Standard:

3.2.1 *birefringence*—retardation per unit thickness, δ/t .

3.2.2 *retardation*, δ —distance (nm) between two wave fronts resulting from passage of light through a birefringent material. (Also called “relative retardations.”)

3.2.3 *strain*, ϵ -strain (or deformation per unit length)—could be permanent, plastic strain introduced in manufacturing process, or elastic strain related to the existing state of stress. Both types of strains will produce strain-birefringence in most polymers. Birefringence can also result from optical anisotropy due to crystalline orientation.

3.2.4 *strain-optical constant*, k —material property, relating the strains to changes of index of refraction (dimensionless).

$$k = (n_1 - n_2)/(\epsilon_1 - \epsilon_2)$$

3.2.5 *stress-optical constant*, C —material property relating the stresses to change in index of refraction. C is expressed in m^2/N or Brewsters ($10^{-12} m^2/N$). C is usually temperature-dependent.

$$C = (n_1 - n_2)/(\sigma_1 - \sigma_2)$$

4. Summary of Test Method

4.1 To analyze strains photoelastically, two quantities are measured: (a) the directions of principal strains and (b) the retardation, δ , using light paths crossing the investigated material in normal or angular incidence.

4.2 The investigated specimen or sample is introduced between the polarizers (see Fig. 2 and Fig. 3). A synchronous rotation of polarizers follows until light intensity becomes zero at the observed location. The axes of the polarizers are then parallel to direction of strains, revealing these directions.

4.3 To suppress the directional sensitivity of the apparatus, the setup is changed, introducing additional filters. A calibrated compensator is introduced and its setting adjusted until light intensity becomes zero at the observed location. The retardation in the calibrated compensator is then equal and opposite in sign to the retardation in the investigated specimen (see Fig. 4).

5. Significance and Use

5.1 The observation and measurement of strains in transparent or translucent materials is extensively used in various modeling techniques of experimental stress analysis.

² Annual Book of ASTM Standards, Vol 08.01.

³ Annual Book of ASTM Standards, Vol 08.02.

⁴ Annual Book of ASTM Standards, Vol 14.02.

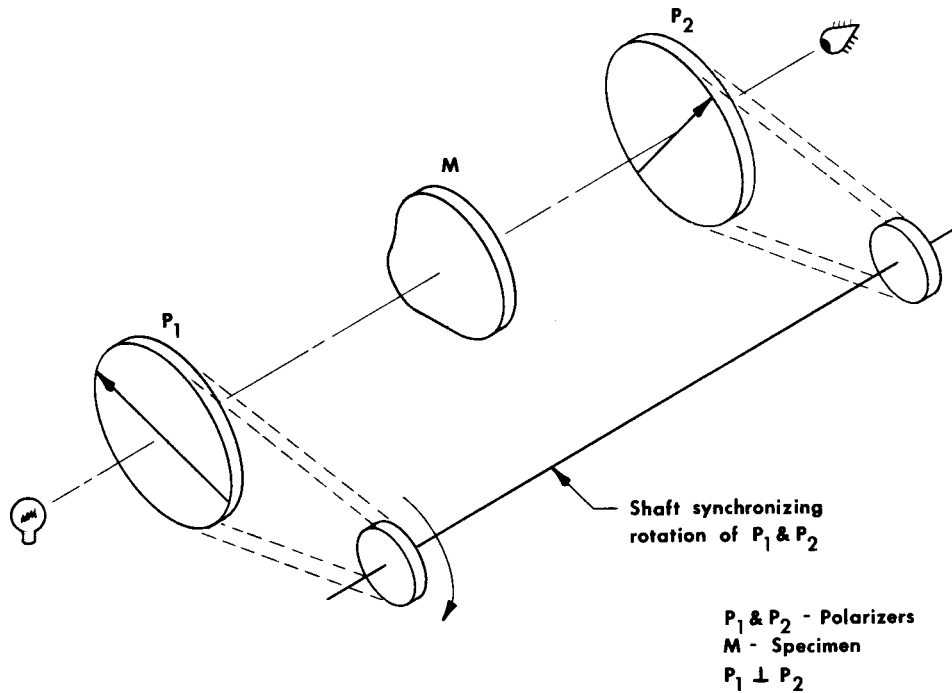

FIG. 2 Transmission Set-up of Polariscope

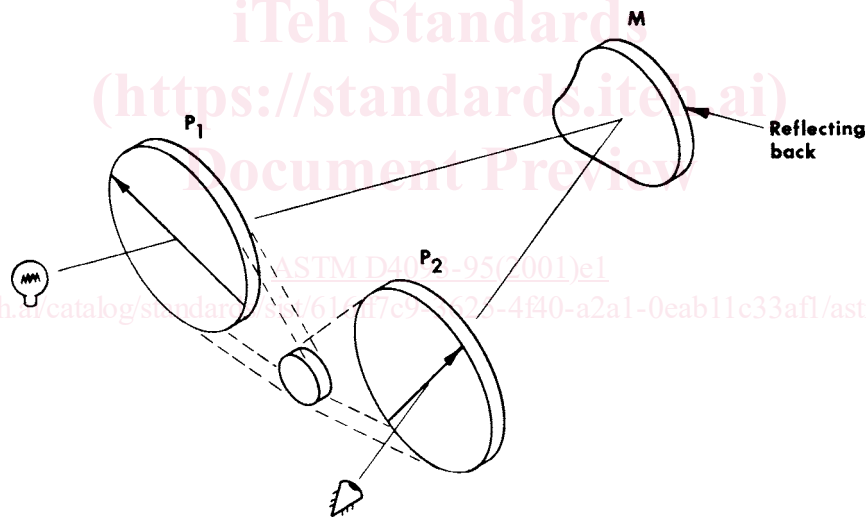

FIG. 3 Reflection Set-up of Polariscope

5.2 Internal strains induced in manufacturing processes such as casting, molding, welding, extrusion, and polymer stretching can be assessed and part exhibiting excessive strains identified. Such measurements can lead to elimination of defective parts, process improvement, control of annealing operation, etc.

5.3 When testing for physical properties, polariscopic examination of specimens is required, to eliminate those specimens exhibiting abnormal internal strain level (or defects). For example: Test Methods D 638 (Note 8) and D 882 (Note 11) recommend a polariscopic examination.

5.4 The birefringence of oriented polymers can be related to orientation, shrinkage, etc. The measurements of birefringence aid in characterization of these polymers.

5.5 For many materials, there may be a specification that requires the use of this test method, but with some procedural

modifications that take precedence when adhering to the specification. Therefore, it is advisable to refer to that material specification before using this test method. Table 1 of Classification System D 4000 lists the ASTM materials standards that currently exist.

6. Apparatus

6.1 The apparatus used to measure strains is shown schematically in Fig. 4. It consists of the following items:

6.1.1 Light Source:

6.1.1.1 *Transmitted-Light Set-Up*—An incandescent lamp or properly spaced fluorescent tubes covered with a diffuser should provide a uniformly diffused light. To ensure adequate brightness, minimum illumination required is 0.3 W/in.² (0.0465 W/cm²). Maximum light source power is limited to

ensure that the specimen temperature will not change more than 2°C during the test. The incandescent lamp must be selected to provide a color temperature no lower than 3150 K. There should be no visible nonuniformity, dark or bright spots

polarizers is recommended. The polarizers must be mechanically or electrically coupled to insure their mutually perpendicular setting while rotated together to measure directions. A graduated scale must be incorporated to indicate the common

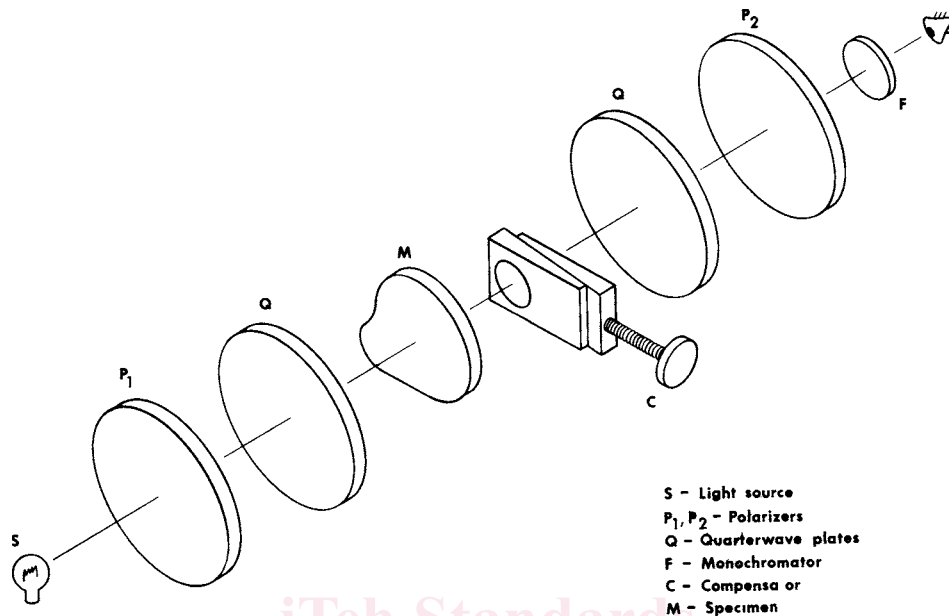

FIG. 4 Apparatus

DIRECTION MEASURING SET-UP

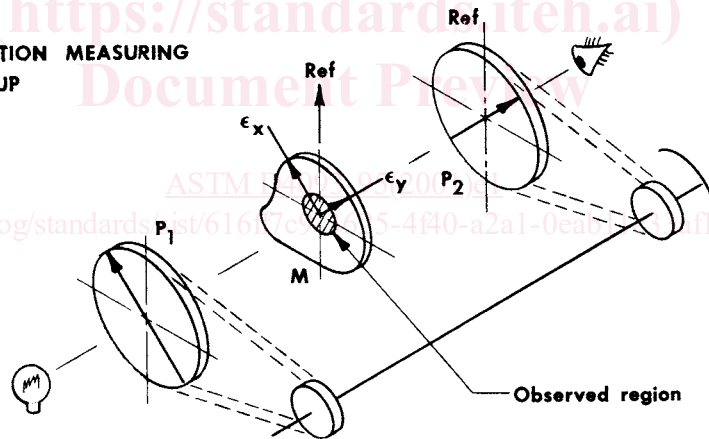

FIG. 5 Direction Measuring Set-up

on the diffuser surface, when no specimen is inserted in the apparatus.

6.1.1.2 *Reflection-Light Source*—For the reflection set-up an incandescent, reflector-equipped projection lamp is required. The lamp shall be equipped with proper lenses to ensure uniform illumination of the investigated object. At a distance of 2 ft (610 mm) from the lamp an area of 1 ft² (0.093 m²) should be illuminated, with no visible dark or bright spots. The lamp power should be at least 150 W.

6.1.2 *Polarizer*—The polarizing element shall be kept clean. The ratio of the transmittance of polarizers with their axes parallel, to the transmittance of the polarizers with their axes perpendicular to each other (or in crossed position), should not be less than 500. A glass-laminated construction of

rotation of polarizers to a fixed reference mark.

6.1.3 *Quarter-Wave Plates*—Two quarter-wave plates are required in the procedure described below (see 9.2):

6.1.3.1 The retardation of each quarter-wave plate shall be 142 ± 15 nm, uniform throughout its transmission area. The difference in retardation between the two quarter-wave plates should not exceed ± 5 nm.

6.1.3.2 The quarter-wave plates will be indexed, to permit their insertion in the field of the apparatus with their axes at 45° to the polarizers direction. The two quarter-wave plates shall have their axes crossed (that is, their optical axes perpendicular to each other), thus insuring that the field remains at maximum darkness when both quarter-wave plates are inserted (see Fig. 5).

6.1.4 *Compensator*—The compensator is the essential means of measuring retardation. The following types of compensators can be used:

6.1.4.1 *Linear Compensator*⁵—In the linear compensator the retardation in the compensator is linearly variable along its length. A graduated scale shall be attached to the compensator body in such a manner that slippage cannot occur. The calibration characteristic of the compensator shall include the position along its length (as indicated by the scale) of the line where the retardation is zero and the number of divisions d per unit retardation (usually one wavelength). (The retardation per division is $D = \lambda/d$.) The scale density shall be sufficient to provide clear visibility for observing 1 % of the useful range of the compensator.

6.1.4.2 *Uniform Field Compensator*⁶—The uniform field compensator is usually constructed from two optical wedges moved by means of a lead screw, the amount of relative motion being linearly related to the total thickness and the retardation. The lead screw motion shall be controlled by a dial drum or counter. Calibration of this compensator shall include the position, as indicated by the drum or counter, where the retardation is zero and the number of division of drum or counter d per unit of retardation. (The retardation per division is $D = \lambda/d$.)

6.1.5 *Filter*—Monochromatic light is required to perform various operations in photoelasticity and some operations cannot be successfully accomplished using white light. In those instances a monochromatic light can be obtained introducing within the light path, a filter transmitting only light of the desired wave length. To best correlate with observation in white light, a narrow band-pass filter with peak transmittance at 570 ± 6 nm and a maximum transmitted band-width (at half-peak point) of 10 nm should be used.

7. Test Specimen

7.1 Sheet, film, or more generally, a constant-thickness item can be examined using a transmission set-up. For use in reflection, a reflecting surface must be provided. This can be accomplished by painting one side of the specimen with aluminum paint.⁷ Alternatively, it is possible to place the examined sheet specimen against a clean metal surface (preferably aluminum) or an aluminum-painted surface.⁸

7.2 Examination of complex surfaces or shapes sometimes requires the use of an immersion liquid. The examined item is placed inside a tank containing a liquid selected to exhibit approximately the same index of refraction as the tested item. This technique is commonly used to examine three-dimensional shapes.

7.3 If conditioning is required, Procedure A of Practice D 618 shall be used.

8. Calibration and Standardization

8.1 A periodic verification (every 6 months) is required to ensure that the apparatus is properly calibrated. The following points require verification:

8.1.1 *Verification of Polariscope:*

8.1.1.1 Verify that the polarizers remain in “crossed” position. A small deviation of one of the polarizers produces an increase in the light intensity transmitted.

8.1.1.2 Verify that the quarter-wave plates are properly crossed. A small deviation of one quarter-wave plate from its “indexed” position will produce an increase in the light intensity transmitted.

8.1.2 *Verification of the Compensator—:*

8.1.2.1 Examine the compensator in the polariscope and verify that its $\delta = 0$ point coincides with the calibration reported.

8.1.2.2 Using monochromatic light (filter), verify that the spacing of interference fringes, D , coincides with the calibration report. If λ is the wavelength of monochromatic light used, it should be verified that $d = \lambda/D$.

9. Procedure

9.1 *Measuring Direction of Principal Strains:*

9.1.1 Insert the specimen between the polarizers and align a characteristic reference direction of the specimen (for example: edge, axis of symmetry, base) with the reference of the instrument.

9.1.2 Set the polariscope in the direction measuring set-up. The quarter-wave plates must be removed or their axes aligned with the polarizers (see Fig. 5).

9.1.3 Observe the light intensity at the point (s) (or the region) where measuring is to be performed. Rotate polarizers (synchronized together) until a minimum of light intensity emerges and the point (s) (or the region) appear dark or black.

9.1.4 Read on the dial the angle indicating the directions of the polarizer axes which are also the direction of principal strains at the point with respect to the reference direction.

9.1.5 In polarizing microscopes the polarizer and analyzer remain fixed while the specimen stage rotates. The polarizer in this setup must be aligned with the reference of the stage scale. Rotate the stage until a minimum of light intensity is observed and the area or point that is observed is dark or black. Read on stage scale the angle indicating the rotation of the stage to the reference, which is also the direction angle of the strain to the same reference.

NOTE 1—If the field of view appears dark and remains dark as the polarizers are rotated, the specimen is strain-free. If continuous rotation cannot produce total extinction (black), small changes of strain direction within the thickness of the observed region could be present. If no minimum light can be detected, the variations of strain directions are significant and the method described here is not applicable.

9.2 *Measuring Retardation Using a Linear (Babinet-Type) Compensator (Procedure A)*—The measurement of the retardation, δ , can be performed after the direction of strains has been established. Two set-ups are possible:

(a) Place polarizers at 45° to the direction of principal strains measured in 9.1 (Fig. 6), or

⁵ Also known as “Babinet” compensator.

⁶ Also known as “Babinet-Soleil” compensator.

⁷ Krylon aluminum aerosol can spray paint was found satisfactory.

⁸ Supporting data are available from ASTM Headquarters. Request RR: D20-1121.

RETARDATION MEASURING SET-UP

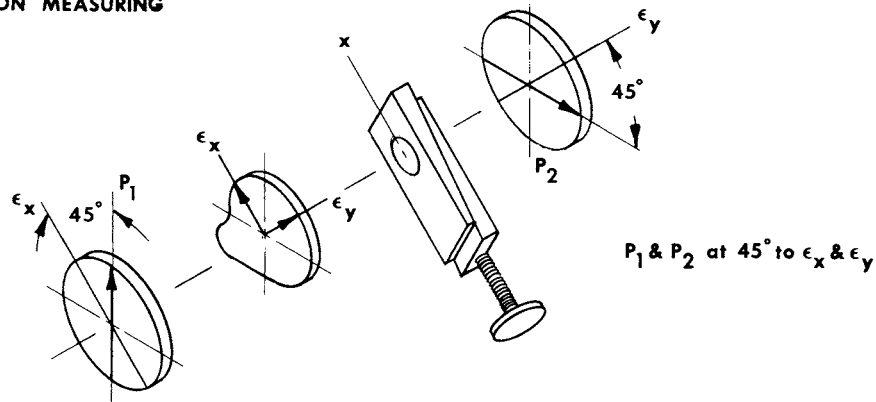

FIG. 6 Retardation Measuring Set-up

(b) Insert two quarter-wave plate filters at 45° to the polarizers, with their axes crossed, as shown on Fig. 7. This set-up facilitates the observation of the specimen and selection of points for measurement when directions of strain vary significantly from point to point on the specimen.

9.2.1 After completing the set-up (b) or (c), observe and identify the point of measurement. The color versus retardation table (Appendix X1) provides a simple means to select the point of measurement properly. Uniform color observed over a broad region indicates a uniform strain area. Closely spaced color bands (isochromatics) indicate that strain gradient are substantial and the points must be selected carefully to provide meaningful data.

9.2.2 Introduce the compensator in the field of view, with the axes, xy , of the compensator closely aligned with the direction of principal strains, ϵ_x and ϵ_y , in the specimen. The retardation produced by the specimen and the compensator are additive, producing the shift of color fringes in the compensator. Two mutually perpendicular positions of the compensator are possible; select the position which produces an upscale (toward larger number) shift of the black fringe.

9.2.3 Determine the shift of the black fringe (d division). If the compensator calibration constant is D nm per division, the measured retardation is:

$$\delta = Dd \text{ nm}$$

9.3 Measuring the Retardation Using a "Uniform Field" (Babinet-Soleil)-Type Compensator (Procedure B):

9.3.1 Set up the polariscope (as indicated in 9.2).

9.3.2 Introduce the compensator, with its axes aligned with the direction, ϵ_x and ϵ_y , of measured strains. Observe the light transmitted by the specimen and the compensator and adjust the retardation of the compensator (advancing its lead-screw) until the total retardation observed is zero and a black fringe or area covers the observed point or region.

9.3.2.1 Two positions of the compensator are possible. Compensation can be accomplished in one of these positions. If the calibration of the compensator is D nm per division and d is the observed lead screw advance (drum or counter reading), the measured retardation is:

$$\delta = Dd \text{ nm}$$

The compensator also indicates which of the two directions, x or y , coincides with the larger index of refraction ($n_x > n_y$ or $n_y > n_x$).

9.4 At every point where measurement of stress is performed, in addition to measuring the retardation, measure the thickness, t , using a suitable micrometer.

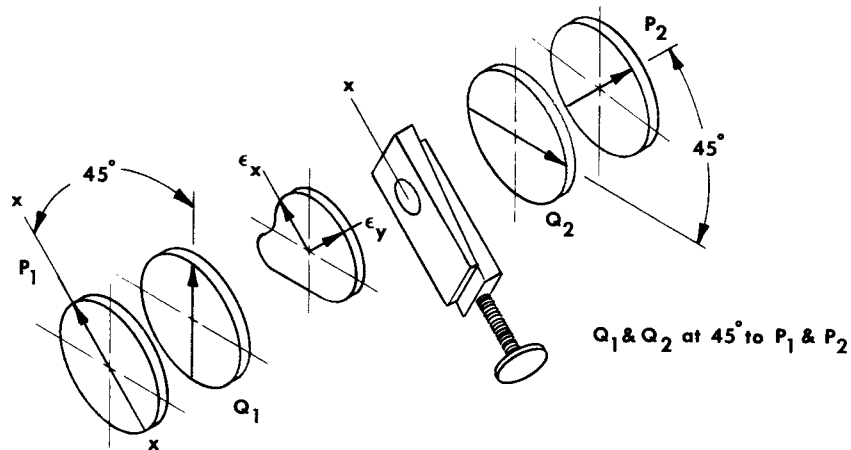

FIG. 7 Retardation Measuring Set-up