**Digital cinema (D-cinema) operations —
Part 9:
Key delivery bundle**

*Opérations du cinéma numérique (cinéma D) —
Partie 9: Paquet principal de livraison*

**iTeh STANDARD PREVIEW
(standards.iteh.ai)**

ISO 26430-9:2009

<https://standards.iteh.ai/catalog/standards/sist/7fcf2f14-6c43-4b96-943f-a5f37ab4566b/iso-26430-9-2009>



PDF disclaimer

This PDF file may contain embedded typefaces. In accordance with Adobe's licensing policy, this file may be printed or viewed but shall not be edited unless the typefaces which are embedded are licensed to and installed on the computer performing the editing. In downloading this file, parties accept therein the responsibility of not infringing Adobe's licensing policy. The ISO Central Secretariat accepts no liability in this area.

Adobe is a trademark of Adobe Systems Incorporated.

Details of the software products used to create this PDF file can be found in the General Info relative to the file; the PDF-creation parameters were optimized for printing. Every care has been taken to ensure that the file is suitable for use by ISO member bodies. In the unlikely event that a problem relating to it is found, please inform the Central Secretariat at the address given below.

iTeh STANDARD PREVIEW
(standards.iteh.ai)

ISO 26430-9:2009

<https://standards.iteh.ai/catalog/standards/sist/7fcf2f14-6c43-4b96-943f-a5f37ab4566b/iso-26430-9-2009>



COPYRIGHT PROTECTED DOCUMENT

© ISO 2009

All rights reserved. Unless otherwise specified, no part of this publication may be reproduced or utilized in any form or by any means, electronic or mechanical, including photocopying and microfilm, without permission in writing from either ISO at the address below or ISO's member body in the country of the requester.

ISO copyright office
Case postale 56 • CH-1211 Geneva 20
Tel. + 41 22 749 01 11
Fax + 41 22 749 09 47
E-mail copyright@iso.org
Web www.iso.org

Published in Switzerland

Foreword

ISO (the International Organization for Standardization) is a worldwide federation of national standards bodies (ISO member bodies). The work of preparing International Standards is normally carried out through ISO technical committees. Each member body interested in a subject for which a technical committee has been established has the right to be represented on that committee. International organizations, governmental and non-governmental, in liaison with ISO, also take part in the work. ISO collaborates closely with the International Electrotechnical Commission (IEC) on all matters of electrotechnical standardization.

International Standards are drafted in accordance with the rules given in the ISO/IEC Directives, Part 2.

The main task of technical committees is to prepare International Standards. Draft International Standards adopted by the technical committees are circulated to the member bodies for voting. Publication as an International Standard requires approval by at least 75 % of the member bodies casting a vote.

Attention is drawn to the possibility that some of the elements of this document may be the subject of patent rights. ISO shall not be held responsible for identifying any or all such patent rights.

ISO 26430-9 was prepared by the Society of Motion Picture and Television Engineers (as SMPTE 430-9-2008) and was adopted, under a special “fast-track procedure”, by Technical Committee ISO/TC 36, *Cinematography*, in parallel with its approval by the ISO member bodies.

ISO 26430 consists of the following parts, under the general title *Digital cinema (D-cinema) operations*:

- *Part 1: Key delivery message* [equivalent to SMPTE 430-1]
- *Part 2: Digital certificate* [equivalent to SMPTE 430-2]
- *Part 3: Generic extra-theater message format* [equivalent to SMPTE 430-3]
- *Part 4: Log record format specification* [equivalent to SMPTE 430-4]
- *Part 5: Security log event class and constraints* [equivalent to SMPTE 430-5]
- *Part 6: Auditorium security messages for intra-theater communications* [equivalent to SMPTE 430-6]
- *Part 9: Key delivery bundle* [equivalent to SMPTE 430-9]

Introduction

This part of ISO 26430 comprises SMPTE 430-9-2008 and Annex ZZ (which provides equivalences between ISO standards and SMPTE standards referenced in the text).

iTeh STANDARD PREVIEW (standards.iteh.ai)

ISO 26430-9:2009

<https://standards.iteh.ai/catalog/standards/sist/7fcf2f14-6c43-4b96-943f-a5f37ab4566b/iso-26430-9-2009>

SMPTE STANDARD

D-Cinema Operations —
Key Delivery Bundle

Table of Contents

	Page
Foreword	2
1 Scope	3
2 Conformance Notation	3
3 Normative References	3
4 Overview (Informative)	4
5 Bundle File Format	4
6 Basic KDMb Elements and D-Cinema Relationships	4
6.1 CATALOG File	4
6.2 CONTENT Directory	5
7 Catalog Element	6
7.1 Id	6
7.2 AnnotationText (Optional)	6
7.3 Creator (Optional)	6
7.4 KDMFileList	6
8 KDMFile Element	7
8.1 CPLId	7
8.2 FilePath	7
8.3 Recipient	8
9 XML Schema	9
10 Bundle Catalog File Example (Informative)	10
11 XML Diagram Legend (Informative)	12
11.1 Element Symbols	12
11.2 Model Symbols ("Compositors")	13
11.3 Types	13
11.4 Model Groups and References	14
Annex A Bibliography (Informative)	15

Table of Figures

Figure 1 KDM Bundle Structure Overview	4
Figure 2 Catalog Relationships	5
Figure 3 CatalogType Structure	6
Figure 4 KDMFileType Structure	7
Figure 5 KDM Recipient Structure	8

Foreword

SMPTE (the Society of Motion Picture and Television Engineers) is an internationally-recognized standards developing organization. Headquartered and incorporated in the United States of America, SMPTE has members in over 80 countries on six continents. SMPTE's Engineering Documents, including Standards, Recommended Practices and Engineering Guidelines, are prepared by SMPTE's Technology Committees. Participation in these Committees is open to all with a bona fide interest in their work. SMPTE cooperates closely with other standards-developing organizations, including ISO, IEC and ITU.

SMPTE Engineering Documents are drafted in accordance with the rules given in Part XIII of its Administrative Practices.

SMPTE Standard 430-9 was prepared by Technology Committee DC28.

iTeh STANDARD PREVIEW (standards.iteh.ai)

[ISO 26430-9:2009](https://standards.iteh.ai/catalog/standards/sist/7fcf2f14-6c43-4b96-943f-a5f37ab4566b/iso-26430-9-2009)

<https://standards.iteh.ai/catalog/standards/sist/7fcf2f14-6c43-4b96-943f-a5f37ab4566b/iso-26430-9-2009>

1 Scope

This document specifies the Key Delivery Message bundle (KDMb). The KDMb is designed to deliver a set of Key Delivery Messages [KDM] from a D-Cinema content processing center to a consumer or redistributors of KDM elements (e.g., from post production to distribution, or from distribution to exhibition). The KDMb can represent an entire theatre, circuit or other grouping of recipients. The KDMb is a compressed archive that contains a mapping file and a directory containing a collection of one or more KDM files. The mapping file defines a relationship between a Composition Playlist [CPL], a Recipient and a KDM. The mapping file allows for a fast look-up of a KDM elements for CPL or Recipient. The intent of the KDMb is to distribute a set of KDM elements in a single compressed container for improved distribution efficiencies.

2 Conformance Notation

Normative text is text that describes elements of the design that are indispensable or contains the conformance language keywords: "shall", "should", or "may". Informative text is text that is potentially helpful to the user, but not indispensable, and can be removed, changed, or added editorially without affecting interoperability. Informative text does not contain any conformance keywords.

All text in this document is, by default, normative, except: the Introduction, any section explicitly labeled as "Informative" or individual paragraphs that start with "Note:"

The keywords "shall" and "shall not" indicate requirements strictly to be followed in order to conform to the document and from which no deviation is permitted.

The keywords, "should" and "should not" indicate that, among several possibilities, one is recommended as particularly suitable, without mentioning or excluding others; or that a certain course of action is preferred but not necessarily required; or that (in the negative form) a certain possibility or course of action is deprecated but not prohibited.

The keywords "may" and "need not" indicate courses of action permissible within the limits of the document.

The keyword "reserved" indicates a provision that is not defined at this time, shall not be used, and may be defined in the future. The keyword "forbidden" indicates "reserved" and in addition indicates that the provision will never be defined in the future.

A conformant implementation according to this document is one that includes all mandatory provisions ("shall") and, if implemented, all recommended provisions ("should") as described. A conformant implementation need not implement optional provisions ("may") and need not implement them as described.

3 Normative References

The following standards contain provisions which, through reference in this text, constitute provisions of this standard. At the time of publication, the editions indicated were valid. All standards are subject to revision, and parties to agreements based on this standard are encouraged to investigate the possibility of applying the most recent edition of the standards indicated below.

World Wide Web Consortium (W3C) (2004, February 4). *Extensible Markup Language (XML) 1.0 (Third Edition)*

World Wide Web Consortium (W3C) (2004, October 28). *XML Schema Part 1: Structures (Second Edition)*

World Wide Web Consortium (W3C) (2004, October 28). *XML Schema Part 2: Datatypes (Second Edition)*

Internet Engineering Task Force (IETF) (November 1996) RFC1738 — *Uniform Resource Locators (URL)*

SMPTE 430-9-2008

Internet Engineering Task Force (IETF) (1996, November). RFC 2396 — *Uniform Resource Identifiers (URI): Generic Syntax*

Internet Engineering Task Force (IETF) (2005, July). RFC 4122 — *A Universally Unique Identifier (UUID) URN Namespace.7*

SMPTE 429-7-2006, D-Cinema Packaging — *Composition Playlist*

SMPTE 429-8-2007, D-Cinema Packaging — *Packing List*

SMPTE 430-1-2006, D-Cinema Operations — *Key Delivery Message*

IEEE Std 1003.1-2004, Standard for Information Technology — *Portable Operating System Interface (POSIX)*

4 Overview (Informative)

The Bundle is designed to deliver a collection of Key Delivery Messages [KDM] from a D-Cinema content processing center to a consumer or redistributors of KDM elements (e.g., from post production to distribution, or from distribution to exhibition). The Bundle can contain KDMs for an entire theatre, circuit or other grouping of recipients. The Bundle is a single archive file that contains a Catalog file and a collection of one or more KDM files in a hierarchical directory structure. The Catalog file defines a relationship between a Composition Playlist [CPL], a Recipient and a KDM contained in the Bundle. The Catalog file allows for a fast look-up of KDM associated with a CPL or Recipient. The intent of the Bundle is to distribute a set of KDM files in a single container for improved distribution efficiencies.

It is recommended that the reader become familiar with the Key Delivery Message [KDM] and Composition Playlist [CPL] specifications in order to fully understand the concepts expressed within this document.

5 Bundle File Format

<https://standards.iteh.ai/catalog/standards/sist/7fc2f14-6c43-4b96-943f-a5f37ab4566b/iso-26430-9-2009>

The Bundle file format shall follow the ustar Interchange Format defined in IEEE Std 1003.1(POSIX).

6 Basic KDMb Elements and D-Cinema Relationships

The Bundle shall contain at its top-level a single text file named CATALOG and a single directory named CONTENT that contains one or more KDM files. Other top-level files and directories shall be ignored.

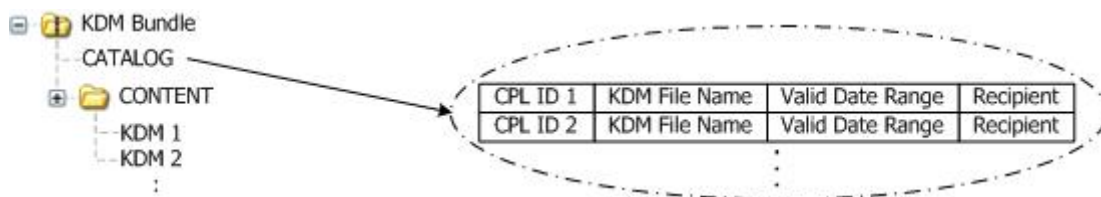

Figure 1 – KDM Bundle Structure Overview

6.1 CATALOG File

The CATALOG file is encoded using the Extensible Markup Language (XML) [XML 1.0]. It shall contain a single Catalog element, as defined in the following sections.

The Catalog element is specified using XML Schema [XML Schema Part 1: Structures] and [XML Schema Part 2: Datatypes]. This specification shall be associated with a unique XML namespace name [Namespaces in XML]. The namespace name shall be the string value "http://www.smpte-ra.org/schemas/429-10/2008/KDMB".

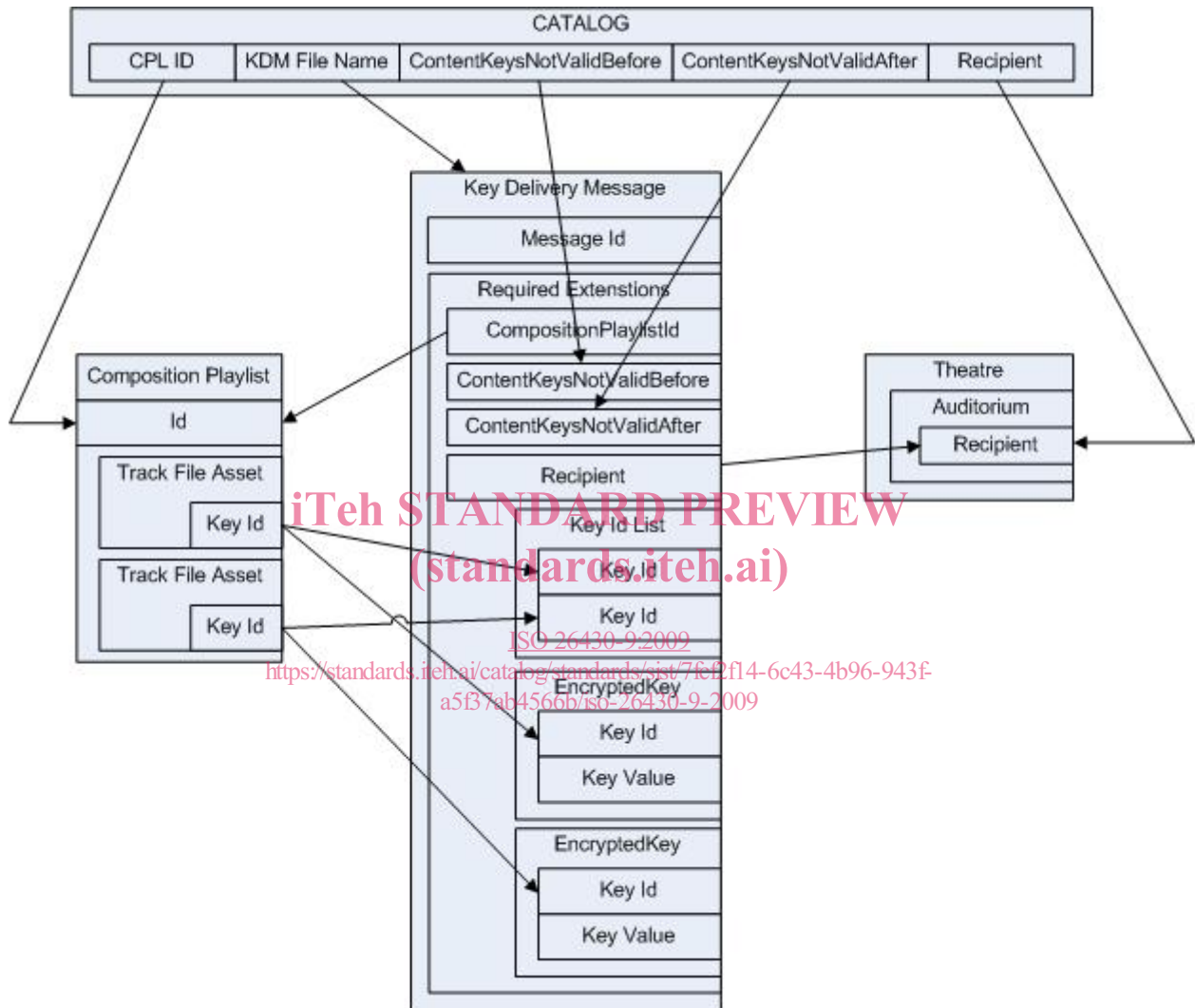

Figure 2 – Catalog Relationships

6.2 CONTENT Directory

The CONTENT directory shall contain one or more files. Each file shall contain a single Key Delivery Message, as specified in [KDM]. Any file name permitted by the ustar Interchange Format is allowed.

7 Catalog Element

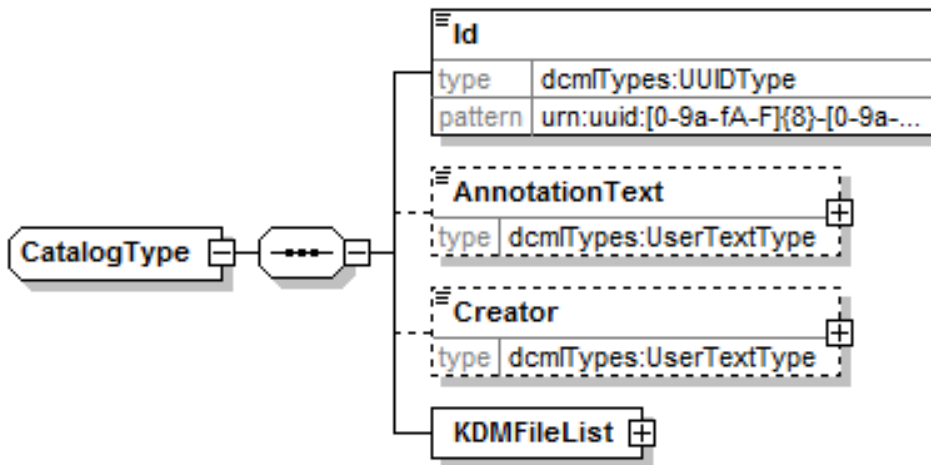

Figure 3 – CatalogType Structure

7.1 Id

Id shall be encoded as a urn:uuid per [RFC 4122]. The Id element uniquely identifies the Catalog for asset management purposes.

<http://standards.iteh.ai/catalog/standards/sist/7fc2f14-6c43-4b96-943f-a5f37ab4566b/iso-26430-9-2009>

7.2 AnnotationText [optional]

The Annotation Text element shall be encoded as a dcmTypes:UserTextType. The Annotation Text element shall be a free-form, human-readable annotation describing the Catalog. It is meant strictly as a display hint to the user.

7.3 Creator [optional]

The Creator element shall be encoded as a dcmTypes:UserTextType. The Creator element shall be a free-form, human-readable annotation that shall identify the application used to create the Show Playlist. It is meant strictly for display to the user.

7.4 KDMFileList

The KDMFileList element contains a list of KDMFile elements. Each KDMFile element shall correspond to a single file contained in the CONTENT directory. The structure of the KDMFile element is described in the following section.

8 KDMFile Element

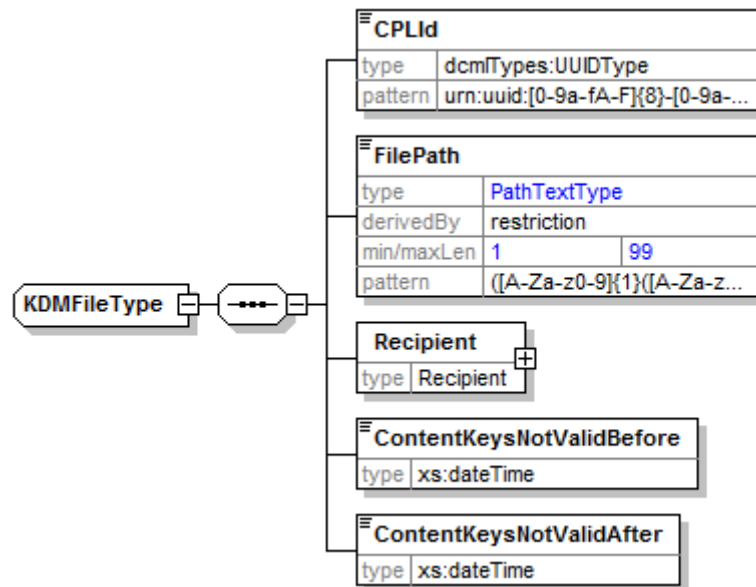

Figure 4 – KDMFileType Structure

iTeh STANDARD PREVIEW
(standards.iteh.ai)

The KDMFile element is used to represent a single KDM file contained in the CONTENT directory. It contains the following elements.

ISO 26430-9:2009

<https://standards.iteh.ai/catalog/standards/sist/7fc2f14-6c43-4b96-943f-a5f37ab4566b/iso-26430-9-2009>

8.1 CPLId

CPLId shall be encoded as a urn:uuid per [RFC 4122]. The CPLId element shall be a copy of the Id of the Composition Playlist associated with the KDM contained in the associated KDM file.

8.2 FilePath

FilePath shall be encoded as a PathTextType element. The FilePath element shall contain the filename of the associated KDM file, relative to the root of the CONTENT directory. The minimum length of the path shall be one character and the maximum length shall not exceed 99 characters.

8.2.1 Archive File Attributes

All of the archive files must have the following attributes:

1. All archive files shall be regular files or directories (no symbolic links or device files).
2. All archive files shall have permission mode (octal) 0444 (read-only).
3. All archive directories shall have permission mode (octal) 0555 (read-only, searchable).
4. All archive files shall have relative pathnames (no absolute paths).
5. All archive files shall have user and group id of 0 (zero).
6. All archive files shall have a text user id and text group id of "root".
7. All archive files shall be case-sensitive, however all names shall be unique without regard to case.