**Medical infusion bottles — Suspension
devices for multiple use — Requirements
and test methods**

*Flacons médicaux de transfusion et de perfusion — Dispositifs de
suspension à usage multiple — Exigences et méthodes d'essai*

iTeh STANDARD PREVIEW
(standards.iteh.ai)

[ISO 15375:2010](https://standards.iteh.ai/catalog/standards/sist/30c8b474-8c02-46b9-952a-f203cbfd996c/iso-15375-2010)

[https://standards.iteh.ai/catalog/standards/sist/30c8b474-8c02-46b9-952a-
f203cbfd996c/iso-15375-2010](https://standards.iteh.ai/catalog/standards/sist/30c8b474-8c02-46b9-952a-f203cbfd996c/iso-15375-2010)



PDF disclaimer

This PDF file may contain embedded typefaces. In accordance with Adobe's licensing policy, this file may be printed or viewed but shall not be edited unless the typefaces which are embedded are licensed to and installed on the computer performing the editing. In downloading this file, parties accept therein the responsibility of not infringing Adobe's licensing policy. The ISO Central Secretariat accepts no liability in this area.

Adobe is a trademark of Adobe Systems Incorporated.

Details of the software products used to create this PDF file can be found in the General Info relative to the file; the PDF-creation parameters were optimized for printing. Every care has been taken to ensure that the file is suitable for use by ISO member bodies. In the unlikely event that a problem relating to it is found, please inform the Central Secretariat at the address given below.

iTeh STANDARD PREVIEW
(standards.iteh.ai)

ISO 15375:2010

<https://standards.iteh.ai/catalog/standards/sist/30c8b474-8c02-46b9-952a-f203cbfd996c/iso-15375-2010>



COPYRIGHT PROTECTED DOCUMENT

© ISO 2010

All rights reserved. Unless otherwise specified, no part of this publication may be reproduced or utilized in any form or by any means, electronic or mechanical, including photocopying and microfilm, without permission in writing from either ISO at the address below or ISO's member body in the country of the requester.

ISO copyright office
Case postale 56 • CH-1211 Geneva 20
Tel. + 41 22 749 01 11
Fax + 41 22 749 09 47
E-mail copyright@iso.org
Web www.iso.org

Published in Switzerland

Foreword

ISO (the International Organization for Standardization) is a worldwide federation of national standards bodies (ISO member bodies). The work of preparing International Standards is normally carried out through ISO technical committees. Each member body interested in a subject for which a technical committee has been established has the right to be represented on that committee. International organizations, governmental and non-governmental, in liaison with ISO, also take part in the work. ISO collaborates closely with the International Electrotechnical Commission (IEC) on all matters of electrotechnical standardization.

International Standards are drafted in accordance with the rules given in the ISO/IEC Directives, Part 2.

The main task of technical committees is to prepare International Standards. Draft International Standards adopted by the technical committees are circulated to the member bodies for voting. Publication as an International Standard requires approval by at least 75 % of the member bodies casting a vote.

Attention is drawn to the possibility that some of the elements of this document may be the subject of patent rights. ISO shall not be held responsible for identifying any or all such patent rights.

ISO 15375 was prepared by Technical Committee ISO/TC 76, *Transfusion, infusion and injection equipment for medical and pharmaceutical use*.

This second edition cancels and replaces the first edition (ISO 15375:2004), Clause 2 of which has been technically revised.

iTeh STANDARD PREVIEW
(standards.iteh.ai)

ISO 15375:2010
<https://standards.iteh.ai/catalog/standards/sist/30c8b474-8c02-46b9-952a-f203cbfd996c/iso-15375-2010>

Introduction

This International Standard deals with permanent suspension devices for multiple use for infusion bottles in accordance with ISO 8536-1. The intended purpose of suspension devices is to avoid dropdowns of infusion bottles during administering of blood or pharmaceutical solutions.

iTeh STANDARD PREVIEW (standards.iteh.ai)

[ISO 15375:2010](https://standards.iteh.ai/catalog/standards/sist/30c8b474-8c02-46b9-952a-f203cbfd996c/iso-15375-2010)

<https://standards.iteh.ai/catalog/standards/sist/30c8b474-8c02-46b9-952a-f203cbfd996c/iso-15375-2010>

Medical infusion bottles — Suspension devices for multiple use — Requirements and test methods

1 Scope

This International Standard specifies requirements for permanent suspension devices, fixed to infusion racks or set-up devices, for infusion bottles that confirm to the requirements of ISO 8536-1. The suspension devices are intended for multiple use.

The purpose of this International Standard is to establish a safe suspension device for infusion bottles during administering of their contents.

2 Normative references

The following referenced documents are indispensable for the application of this document. For dated references, only the edition cited applies. For undated references, the latest edition of the referenced document (including any amendments) applies.

ISO 2768-1, *General tolerances — Part 1: Tolerances for linear and angular dimensions without individual tolerance indications*

ISO 15375:2010

ISO 8536-1, *Infusion equipment for medical use — Part 1: Infusion glass bottles*

3 Designation code and test weights

Permanent suspension devices that comply with the requirements of this International Standard are designated by the description block, followed by a reference to this International Standard, followed by the nominal volume as specified in Table 1.

For example, a permanent suspension device for an infusion bottle that conforms to the requirements of ISO 8536-1 of nominal capacity of 50 ml to 250 ml is designated as follows:

Suspension device ISO 15375 - M 50 - 250

Test weights used for the permanent load test (see 6.4) are also a function of the nominal capacity of the permanent suspension device and are specified in Table 1.

Table 1 — Designation code and test weights for permanent load test

Nominal capacity of the bottles ml	Test weight at 24 h kg
≤ 250	3
> 250	5

4 Material

Materials selected for the permanent suspension device shall ensure that all requirements given in Clause 5 can be met.

Certain materials can be chemically and physically damaged by disinfectants. Therefore, attention should be given to selecting materials that are more inert towards disinfectants and less sensitive to stress cracking and thermal stress.

5 Requirements

5.1 Design

5.1.1 When tested in accordance with 6.1, the multiple suspension device shall enable the installation of the bottle with a perforated transfer set.

The suspension device shall be designed in such a way that an unintentional removal from an infusion rack or set-up device is not possible.

5.1.2 The design of the suspension device shall guarantee that the bottle is in a perpendicular position with a maximum deviation of 15°.

5.1.3 When tested in accordance with 6.2, the design of the suspension device shall guarantee that the bottle does not fall off at angles of up to 45°.

5.1.4 The suspension device shall be resistant to corrosion and practically free from burrs.

5.2 Sterilization and disinfection

ISO 15375:2010

<https://standards.iteh.ai/catalog/standards/sist/30c8b474-8c02-46b9-952a-12550d900230/iso-15375-2010>

The manufacturer's manual shall contain information indicating how the suspension device shall be cleaned, sterilized and disinfected.

5.3 Load

5.3.1 Gravitational load

When tested in accordance with 6.3, the permanent suspension device shall not detach from the infusion bottle. It shall not be damaged by the test.

5.3.2 Permanent load

When tested in accordance with 6.4, the multiple suspension device shall prevent the infusion bottle from falling. It shall not be damaged by the test.

5.4 Life cycle

5.4.1 If the design of the permanent suspension device or materials used in its construction have a limited life cycle ≤ 5 y, the manufacturer shall define the storage conditions and the time period during which a permanent suspension device is considered to be in conformance with this International Standard.

5.4.2 In order to take different user conditions into consideration, the manufacturer shall define assessment criteria to enable the user to establish when the suspension device is no longer usable.

6 Testing

6.1 Assembly test

The bottle with the connected transfer set is attached to the suspension device, e.g. hung on a hook having characteristics in accordance with those shown in Figure 1. Any deviation of the orientation of the bottle from the perpendicular is recorded. The assembly test shall be repeated with all bottle sizes that will be used with the suspension device.

6.2 Sloping test

The suspension device assembled with the bottle and the perforated transfer set is tilted to an angle of 45°. The bottle shall not drop off of the suspension device. The sloping test shall be repeated with all bottle sizes that will be used with the suspension device.

General tolerances are in accordance with class “m” (medium) as defined in ISO 2768-1.

Dimensions in millimetres

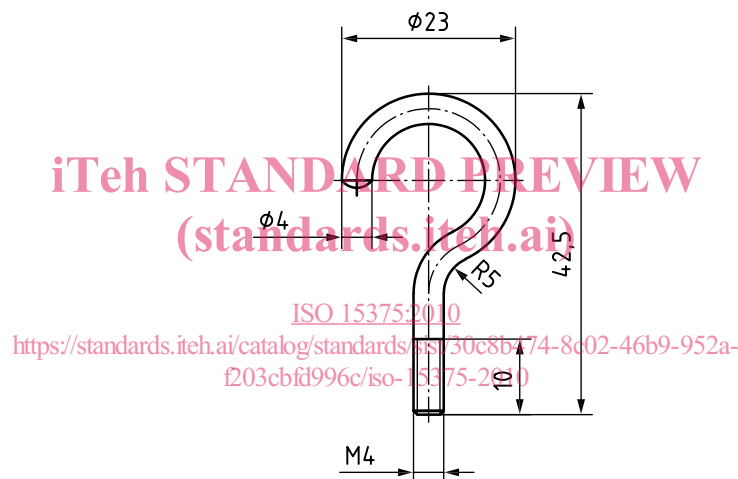

Figure 1 — Test hook

6.3 Gravitational test

Attach the permanent suspension device, fitted with a filled infusion bottle complying with ISO 8536-1, to the test hook (see Figure 1). Attach one end of a cord to the upper part of the hook, and the other end to a separate fixed point.

Hold the suspension device and hook level with the fixed point and drop the assemblage such that the cord stops the fall of the suspension device when it is at a vertical distance of 30 cm from the fixed point.

The suspension device is considered to pass the test if the requirements specified in 5.3.1 are met.

6.4 Permanent load test

Using a hook with a diameter of 4 mm, e.g. in accordance with Figure 1, load the multiple suspension device for 24 h at (23 ± 2) °C and (50 ± 3) % relative humidity with a test weight in accordance with Table 1.

The suspension device is considered to pass the test if the requirements specified in 5.3.2 are met.

iTeh STANDARD PREVIEW
(standards.iteh.ai)

ISO 15375:2010

<https://standards.iteh.ai/catalog/standards/sist/30c8b474-8c02-46b9-952a-f203cbfd996c/iso-15375-2010>

ICS 11.040.20

Price based on 3 pages