**High-pressure flexible connections
for use with medical gas systems**

*Raccords flexibles haute pression pour utilisation avec les systèmes
de gaz médicaux*

iTeh STANDARD PREVIEW
(standards.iteh.ai)

ISO 21969:2009

<https://standards.iteh.ai/catalog/standards/sist/8577c484-ee10-4d6f-b446-5d10e7c23444/iso-21969-2009>



PDF disclaimer

This PDF file may contain embedded typefaces. In accordance with Adobe's licensing policy, this file may be printed or viewed but shall not be edited unless the typefaces which are embedded are licensed to and installed on the computer performing the editing. In downloading this file, parties accept therein the responsibility of not infringing Adobe's licensing policy. The ISO Central Secretariat accepts no liability in this area.

Adobe is a trademark of Adobe Systems Incorporated.

Details of the software products used to create this PDF file can be found in the General Info relative to the file; the PDF-creation parameters were optimized for printing. Every care has been taken to ensure that the file is suitable for use by ISO member bodies. In the unlikely event that a problem relating to it is found, please inform the Central Secretariat at the address given below.

iTeh STANDARD PREVIEW
(standards.iteh.ai)

ISO 21969:2009

<https://standards.iteh.ai/catalog/standards/sist/8577c484-ee10-4d6f-b446-5d10e7c23444/iso-21969-2009>



COPYRIGHT PROTECTED DOCUMENT

© ISO 2009

All rights reserved. Unless otherwise specified, no part of this publication may be reproduced or utilized in any form or by any means, electronic or mechanical, including photocopying and microfilm, without permission in writing from either ISO at the address below or ISO's member body in the country of the requester.

ISO copyright office
Case postale 56 • CH-1211 Geneva 20
Tel. + 41 22 749 01 11
Fax + 41 22 749 09 47
E-mail copyright@iso.org
Web www.iso.org

Published in Switzerland

Contents

Page

Foreword	iv
1 Scope	1
2 * Normative references	2
3 Terms and definitions	2
4 Terminology	3
5 General requirements	4
5.1 Safety	4
5.2 Alternative construction	4
5.3 Materials	4
5.4 Design requirements	4
5.5 Constructional requirements	6
6 Test methods	6
6.1 General	6
6.2 Type tests	7
7 Marking, colour coding and packaging	9
7.1 Marking	9
7.2 Colour coding	10
7.3 Packaging	10
8 Information to be supplied by the manufacturer	10
Annex A (informative) Rationale	12
Bibliography	13

Foreword

ISO (the International Organization for Standardization) is a worldwide federation of national standards bodies (ISO member bodies). The work of preparing International Standards is normally carried out through ISO technical committees. Each member body interested in a subject for which a technical committee has been established has the right to be represented on that committee. International organizations, governmental and non-governmental, in liaison with ISO, also take part in the work. ISO collaborates closely with the International Electrotechnical Commission (IEC) on all matters of electrotechnical standardization.

International Standards are drafted in accordance with the rules given in the ISO/IEC Directives, Part 2.

The main task of technical committees is to prepare International Standards. Draft International Standards adopted by the technical committees are circulated to the member bodies for voting. Publication as an International Standard requires approval by at least 75 % of the member bodies casting a vote.

Attention is drawn to the possibility that some of the elements of this document may be the subject of patent rights. ISO shall not be held responsible for identifying any or all such patent rights.

ISO 21969 was prepared by Technical Committee ISO/TC 121, *Anaesthetic and respiratory equipment*, Subcommittee SC 6, *Medical gas systems*.

This second edition cancels and replaces the first edition (ISO 21969:2005) which has been technically revised.

Annex A contains rationale statements for some of the requirements of this International Standard. It is included to provide additional insight into the reasoning that led to the requirements and recommendations that have been incorporated in this International Standard. The clauses and subclauses marked with an asterisk (*) after their number have corresponding rationale contained in Annex A. It is considered that knowledge of the reasons for the requirements will not only facilitate the proper application of this International Standard, but will also expedite any subsequent revision.

High-pressure flexible connections for use with medical gas systems

1 Scope

1.1 This International Standard applies to high-pressure flexible connections intended to be connected to cylinders or cylinder bundles with nominal filling pressures up to 25 000 kPa at 15 °C for use with the following medical gases:

- oxygen;
- nitrous oxide;
- air for breathing;
- helium;
- carbon dioxide;
- xenon;
- mixtures of the gases listed above;
- air for driving surgical tools;
- nitrogen for driving surgical tools;
- oxygen-enriched air.

iTeh STANDARD PREVIEW
(standards.iteh.ai)

[ISO 21969:2009](https://standards.iteh.ai/catalog/standards/sist/8577c484-ee10-4d6f-b446-5d10e7c23444/iso-21969-2009)

1.2 This International Standard applies to high-pressure flexible connections intended to connect cylinders or cylinder bundles to manifolds within sources of supply of medical gas pipeline systems complying with ISO 7396-1.

1.3 This International Standard applies to high-pressure flexible connections intended to connect a cylinder to an inlet port of medical equipment (e.g. anaesthetic workstation or lung ventilator) fitted with an integral pressure regulator complying with ISO 10524-1.

1.4 This International Standard does not apply to high-pressure flexible connections intended to be used to fill cylinders nor does it apply to low-pressure flexible hose assemblies that are covered by ISO 5359.

2 * Normative references

The following referenced documents are indispensable for the application of this document. For dated references, only the edition cited applies. For undated references, the latest edition of the referenced document (including any amendments) applies.

ISO 32:1977, *Gas cylinders for medical use — Marking for identification of content*

ISO 407:2004, *Small medical gas cylinders — Pin-index yoke-type valve connections*

ISO 5145:2004, *Cylinder valve outlets for gases and gas mixtures — Selection and dimensioning*

ISO 7396-1:2007, *Medical gas pipeline systems — Part 1: Pipeline systems for compressed medical gases and vacuum*

ISO 14971:2007, *Medical devices — Application of risk management to medical devices*

ISO 15001:2003, *Anaesthetic and respiratory equipment — Compatibility with oxygen*

3 Terms and definitions

For the purposes of this document the following terms and definitions apply.

3.1 cylinder bundle

pack or pallet of cylinders linked together with one or more connectors for filling and emptying

3.2 gas-specific

having characteristics which prevent connection between different gas services

3.3 manifold

device for connecting the outlet(s) of one or more cylinders or cylinder bundles of the same gas to the pipeline system

3.4 medical gas

any gas or mixture of gases intended for administration to patients for anaesthetic, therapeutic, diagnostic or prophylactic purposes

3.5 nominal inlet pressure

P_1

pressure for which the high-pressure flexible connection is intended to be used

NOTE P_1 is specified by the manufacturer.

3.6 single fault condition

condition in which a single means for protection against a safety hazard in equipment is defective or a single external abnormal condition is present

NOTE This definition was taken from IEC 60601-1.

4 Terminology

Typical examples of high-pressure flexible connections are given in Figure 1.

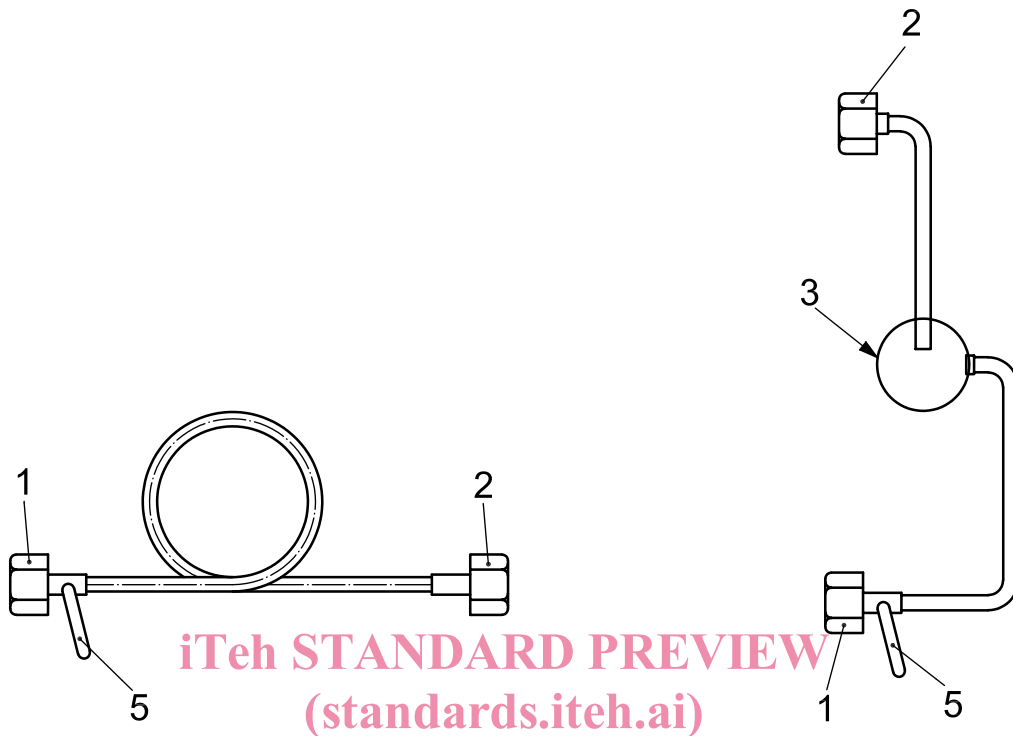

a) Coiled metal pipe (e.g. copper) b) Metal (e.g. copper or stainless steel) pipe connected by a swivel

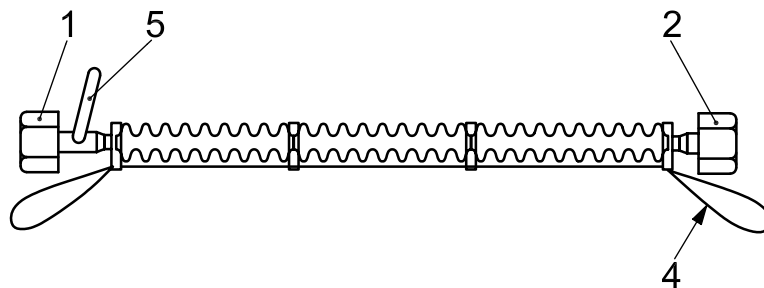

c) Corrugated metal (e.g. stainless steel) hose fitted with retaining straps

Key

- 1 inlet connector
- 2 outlet connector
- 3 swivel
- 4 restraining cable
- 5 handle to prevent torsion

Figure 1 — Typical examples of high-pressure flexible connections

5 General requirements

5.1 Safety

High-pressure flexible connections shall, when transported, stored, installed, operated in normal use and maintained according to the instructions of the manufacturer, present no risks that are not reduced to an acceptable level using risk management procedures in accordance with ISO 14971 and which are connected with their intended application, in normal condition and in single fault condition.

5.2 Alternative construction

High-pressure flexible connections and components or parts thereof, using materials or having forms of construction different from those detailed in Clause 5 shall be presumed to be in compliance with the safety objectives of this International Standard if it can be demonstrated that an equivalent degree of safety is obtained (i.e. compliance with requirements presumes that risks have been mitigated to acceptable levels) unless objective evidence to the contrary becomes available.

Evidence that an equivalent degree of safety is obtained shall be provided by the manufacturer upon request.

5.3 Materials

5.3.1 * The materials in contact with the medical gases listed in 1.1, during normal use shall be resistant to corrosion and compatible with oxygen, with the other medical gases and with their mixtures in the temperature range specified in 5.3.3.

NOTE 1 Corrosion resistance includes resistance against moisture and surrounding materials.

NOTE 2 Compatibility with oxygen involves both combustibility and ease of ignition. Materials that burn in air will burn violently in pure oxygen. Many materials that do not burn in air will do so in pure oxygen, particularly under pressure. Similarly, materials that can be ignited in air require lower ignition energies for ignition in oxygen. Many such materials can be ignited by friction at a valve seat or by adiabatic compression produced when oxygen at high pressure is rapidly introduced into a system initially at low pressure.

NOTE 3 Criteria for the selection of metallic and non-metallic materials are given in ISO 15001.

5.3.2 * Non-metallic (e.g. polymer-lined or rubber-reinforced) flexible hoses shall not be used.

5.3.3 The materials shall permit the high-pressure flexible connections and their components to meet the requirements of 5.4 in the temperature range of – 20 °C to + 60 °C.

NOTE Regional or national environmental conditions may require deviation from this range of temperatures.

5.3.4 High-pressure flexible connections shall meet the requirements of this International Standard after being packed for transport and storage and after being exposed to environmental conditions as stated by the manufacturer.

5.3.5 Evidence of conformity with the requirements of 5.3.1, 5.3.3 and 5.3.4 shall be provided by the manufacturer upon request.

5.4 Design requirements

5.4.1 Inlet connector

The inlet connector, for connection to the cylinder valve, shall be gas-specific and conform to ISO 407, ISO 5145 or the relevant regional or national standard (see ISO/TR 7470 for information).

5.4.2 Outlet connector

5.4.2.1 The outlet connector shall be one of the following:

- a) a connector for connection to the manifold;
- b) a connector for connection to the inlet port of medical equipment; this connector shall be the cylinder valve outlet for the specific medical gas, in accordance with ISO 407, ISO 5145 or the relevant national standard (see ISO/TR 7470 for information).

5.4.2.2 Means shall be provided to prevent the installation of an incorrect high-pressure flexible connection (e.g. by the use of gas-specific connectors) at the manifold (see ISO 7396-1).

5.4.2.3 * If the outlet connector is in accordance with 5.4.2.1 b) and ISO 407, the length of the body shall be at least 15 mm to comply with dimension l_8 in Table 2 of ISO 407:2004.

5.4.3 Torsion

Means shall be provided to prevent torsion of the high-pressure flexible connection during connection and disconnection.

Evidence shall be provided by the manufacturer upon request.

5.4.4 Nominal inlet pressure

A high-pressure flexible connection for any of the medical gases listed in 1.1 shall have a nominal inlet pressure, P_1 , not less than the maximum filling pressure at 15 °C of the medical gas cylinder as specified in regional or national regulations.

5.4.5 Leakage

ISO 21969:2009
<https://standards.iteh.ai/catalog/standards/sist/8577c484-ee10-4d6f-b446-5d10e7c23444/iso-21969-2009>

The maximum external leakage (i.e. leakage to the atmosphere) shall not exceed 0,2 ml/min (equivalent to a pressure drop of 0,020 2 kPa·l/min) at nominal inlet pressure, P_1 .

This test shall be carried out after the test for mechanical strength.

The test for leakage is given in 6.2.1.

5.4.6 Mechanical strength

High-pressure flexible connections shall be capable of withstanding $\times 2,25$ the nominal inlet pressure, P_1 , without permanent deformation.

The test for mechanical strength is given in 6.2.2.

5.4.7 Bursting pressure

The bursting pressure of a high-pressure flexible connection shall not be less than $\times 3$ the nominal inlet pressure, P_1 .

The test for bursting pressure is given in 6.2.3.

5.4.8 * Resistance to ignition

High-pressure flexible connections for the medical gases listed in 1.1 shall not ignite or show internal scorching when subjected to oxygen pressure shocks.

The test for resistance to ignition is given in 6.2.4.