**Fine ceramics (advanced ceramics,
advanced technical ceramics) —
Determination of bulk density of
ceramic powders —**

Part 2:

Untapped density

iTeh STANDARD PREVIEW
(standards.iteh.ai)

*Céramiques techniques — Détermination de la masse volumique des
poudres céramiques —*

*Partie 2: Masse volumique sans tassement
ISO 23145-2:2012*

<https://standards.iteh.ai/catalog/standards/sist/54269895-aba5-402f-a9d1-559da3c3ce8a/iso-23145-2-2012>



iTeh STANDARD PREVIEW (standards.iteh.ai)

ISO 23145-2:2012

<https://standards.iteh.ai/catalog/standards/sist/54269895-aba5-402f-a9d1-559da3c3ce8a/iso-23145-2-2012>



COPYRIGHT PROTECTED DOCUMENT

© ISO 2012

All rights reserved. Unless otherwise specified, no part of this publication may be reproduced or utilized in any form or by any means, electronic or mechanical, including photocopying and microfilm, without permission in writing from either ISO at the address below or ISO's member body in the country of the requester.

ISO copyright office
Case postale 56 • CH-1211 Geneva 20
Tel. + 41 22 749 01 11
Fax + 41 22 749 09 47
E-mail copyright@iso.org
Web www.iso.org

Published in Switzerland

Contents		Page
Foreword		iv
1 Scope		1
2 Normative references		1
3 Principle		1
4 Apparatus		1
5 Sampling		4
6 Procedure		5
7 Calculation		5
8 Test report		5
Bibliography		7

iTeh STANDARD PREVIEW
(standards.iteh.ai)

[ISO 23145-2:2012](https://standards.iteh.ai/catalog/standards/sist/54269895-aba5-402f-a9d1-559da3c3ce8a/iso-23145-2-2012)

<https://standards.iteh.ai/catalog/standards/sist/54269895-aba5-402f-a9d1-559da3c3ce8a/iso-23145-2-2012>

Foreword

ISO (the International Organization for Standardization) is a worldwide federation of national standards bodies (ISO member bodies). The work of preparing International Standards is normally carried out through ISO technical committees. Each member body interested in a subject for which a technical committee has been established has the right to be represented on that committee. International organizations, governmental and non-governmental, in liaison with ISO, also take part in the work. ISO collaborates closely with the International Electrotechnical Commission (IEC) on all matters of electrotechnical standardization.

International Standards are drafted in accordance with the rules given in the ISO/IEC Directives, Part 2.

The main task of technical committees is to prepare International Standards. Draft International Standards adopted by the technical committees are circulated to the member bodies for voting. Publication as an International Standard requires approval by at least 75 % of the member bodies casting a vote.

Attention is drawn to the possibility that some of the elements of this document may be the subject of patent rights. ISO shall not be held responsible for identifying any or all such patent rights.

ISO 23145-2 was prepared by Technical Committee ISO/TC 206, *Fine ceramics*.

ISO 23145 consists of the following parts, under the general title *Fine ceramics (advanced ceramics, advanced technical ceramics)* — *Determination of bulk density of ceramic powders*:

— Part 1: *Tap density*

— Part 2: *Untapped density*

iTeh STANDARD PREVIEW
(standards.iteh.ai)

[ISO 23145-2:2012](https://standards.iteh.ai/catalog/standards/sist/54269895-aba5-402f-a9d1-559da3c3ce8a/iso-23145-2-2012)

<https://standards.iteh.ai/catalog/standards/sist/54269895-aba5-402f-a9d1-559da3c3ce8a/iso-23145-2-2012>

Fine ceramics (advanced ceramics, advanced technical ceramics) — Determination of bulk density of ceramic powders —

Part 2: Untapped density

1 Scope

This part of ISO 23145 specifies the test method to determine the untapped density of granulated or ungranulated ceramic powders by a constant-volume measuring method.

2 Normative references

The following referenced documents are indispensable for the application of this document. For dated references, only the edition cited applies. For undated references, the latest edition of the referenced document (including any amendments) applies.

ISO 565:1990, *Test sieves — Metal wire cloth, perforated metal plate and electroformed sheet — Nominal sizes of openings*

ISO 80000-1:2009, *Quantities and units — Part 1: General*

ISO/IEC 17025:2005, *General requirements for the competence of testing and calibration laboratories*

3 Principle

<https://standards.iteh.ai/catalog/standards/sist/54269895-aba5-402f-a9d1-5591a3-3a8a/iso-23145-2-2012>

The mass of a known volume of the powder is determined after allowing it to fall freely into a stationary container, avoiding vibration. The mass of the powder divided by its volume after the test gives its untapped density.

4 Apparatus

4.1 Funnel (Figure 1), of stainless steel, with an orifice of diameter 2,5 mm and the other with an orifice of diameter 5,0 mm. The funnel shall be made of a non-magnetic, corrosion-resistant metallic material such as stainless steel (for example SUS 304) having sufficient wall thickness and hardness to withstand distortion and excessive wear.

4.2 Cylindrical container (Figure 2), of stainless steel, with a volume of 100 cm³ and a diameter-to-height ratio of approximately 1.

4.3 Sieve, as specified in ISO 565, with an aperture size of 0,71 mm.

4.4 Balance, with a precision of 0,1 g or 0,01 g.

A balance with a precision of 0,01 g should be used for very fluffy powders such as aerosil (fumed silica).

4.5 Straight edge (Figure 3), to remove the cone of surplus powder by gently drawing it.

4.6 Stand and horizontal vibration-free base. A stand to support the funnel concentric with the cylindrical container so that the bottom of the funnel orifice is approximately 50 mm above the top of the cylindrical container when the apparatus is assembled as shown in Figure 4.

Dimensions in millimetres

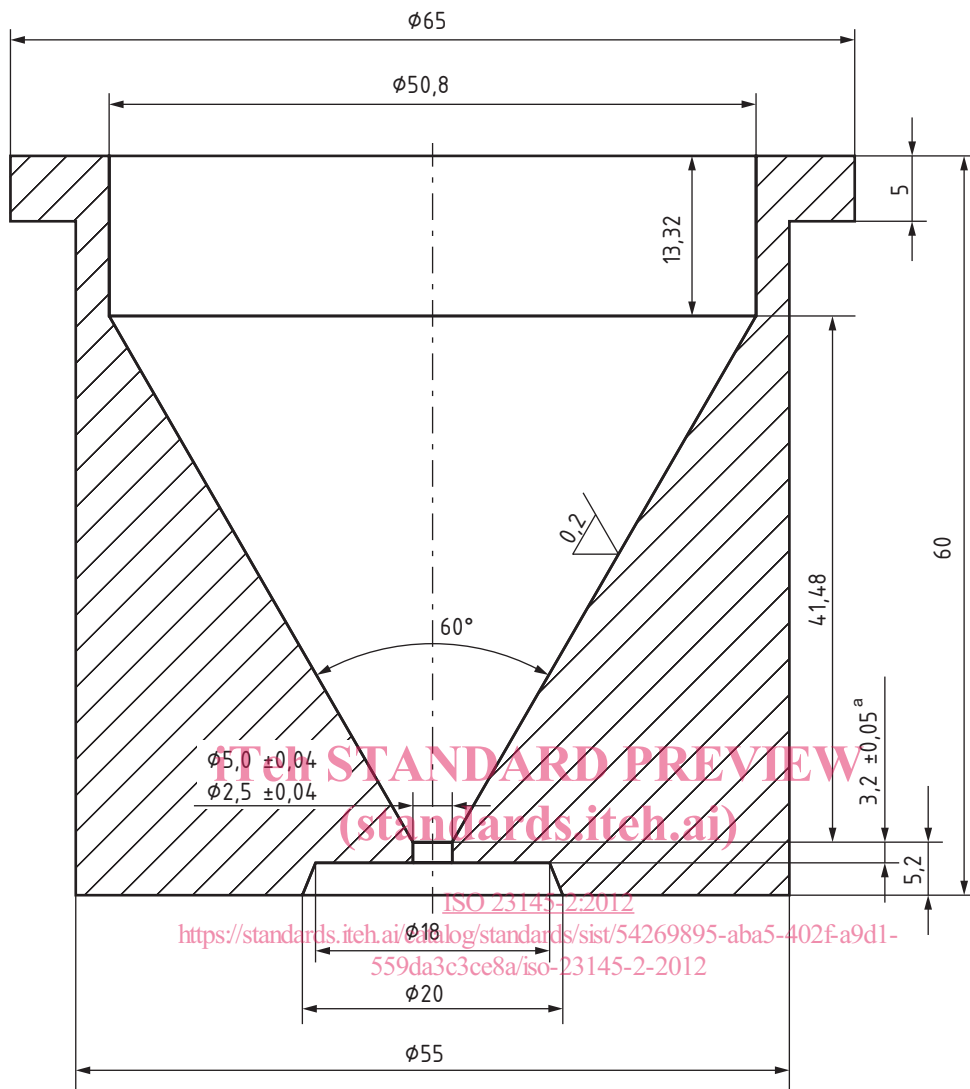

^a Or $6,4 \pm 0,05$ for 5,0 mm diameter.

Figure 1 — Example of a funnel

Dimensions in millimetres

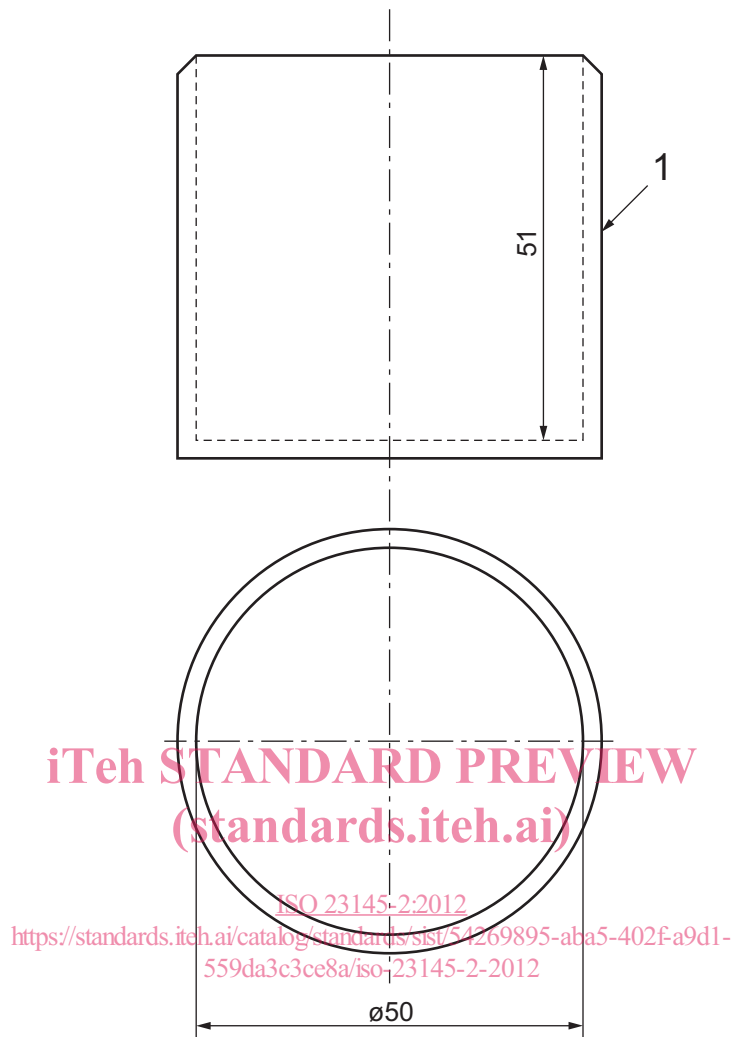

Key

- 1 cylindrical container

Figure 2 — Example of a cylindrical container

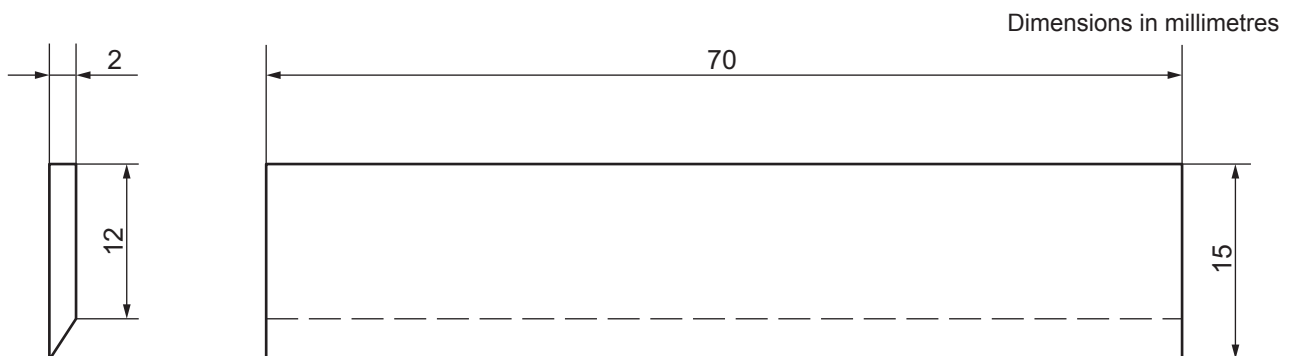
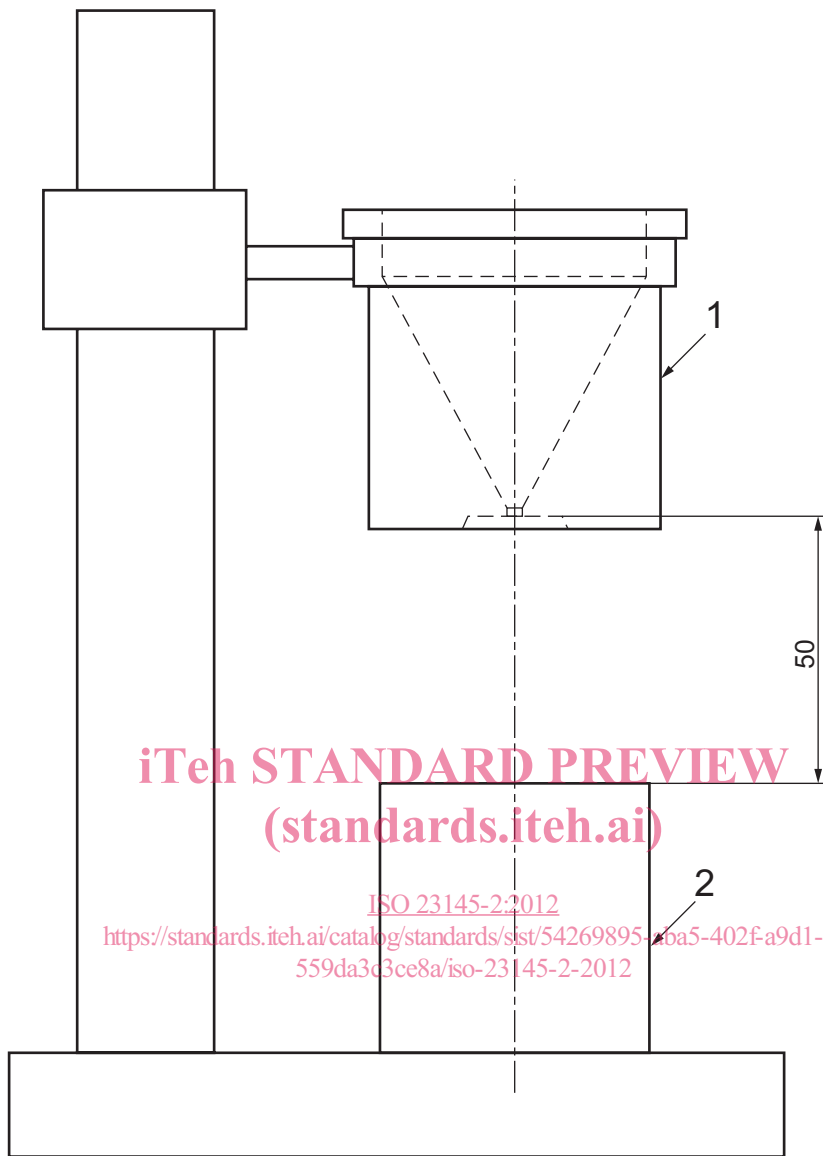

Figure 3 — Example of a straight edge



Key

- 1 funnel
- 2 cylindrical container

Figure 4 — Example of apparatus for untapped density

5 Sampling

5.1 In general, the powder should be tested in the as-received condition. In certain instances the powder may be dried. If the powder is required to be dried, it should be dried at $(110 \pm 5) \text{ }^\circ\text{C}$ for at least 1 h and cooled to room temperature in a desiccator. If the powder contains volatile substances, it shall not be dried.

NOTE If the powder must be dried, it is preferred that the powder be dried until the rate of mass loss is less than 0,1 % (by mass) per 30 min.

5.2 Should there be any treatment (e.g. drying) of the powder before measurement, it shall be recorded in the test report.

5.3 The test shall be carried out on three test portions.

6 Procedure

6.1 Weigh the empty cylindrical container (m_0).

6.2 Pass the ceramic powder through the sieve.

6.3 Fill the funnel having the 2,5 mm diameter orifice with the powder and allow the powder to flow through the orifice into the cylindrical container until it is completely filled and the powder overflows its periphery.

NOTE 1 If the powder does not flow through the 2,5 mm diameter orifice, use the funnel having the 5,0 mm diameter orifice.

NOTE 2 If the powder does not flow through the 5,0 mm diameter orifice, it is allowed to poke the powder within the funnel by a thin wire to stimulate flowing.

6.4 Remove the cone of surplus powder by gently drawing a straight edge across the top rim of the cylindrical container without compressing it and take care not to jar or vibrate the cylindrical container.

6.5 After levelling the powder, tap the cylindrical container lightly to settle the powder in order to avoid spilling it during transport.

6.6 Weigh the cylindrical container and its contents (m_1).

6.7 Repeat the procedure in 6.1 to 6.6 with two additional portions and average the results.

7 Calculation

ISO 23145-2:2012
<https://standards.iteh.ai/catalog/standards/sist/54269895-aba5-402f-a9d1-559da3c3ce8a/iso-23145-2-2012>

Calculate the untapped density from the mass of the powder divided by the volume of the cylindrical container and round the result to 0,001 g/cm³ or 1 kg/m³ in accordance with ISO 80000-1.

$$p_t = \frac{m_1 - m_0}{V} \quad (1)$$

where

p_t is the untapped density, in grams per cubic centimetre, of the ceramic powder;

m_0 is the mass, in grams, of the empty cylindrical container;

m_1 is the mass, in grams, of the cylindrical container full of the powder;

V is the volume, in cubic centimetres, of the cylindrical container (100 cm³)

8 Test report

The test report shall be in accordance with the reporting provisions of ISO/IEC 17025 and shall contain the following information:

- the name of the testing establishment;
- date of the test, report identification and number, operator, signatory;
- temperature and relative humidity in the laboratory
- a reference to this part of ISO 23145;