**Fine ceramics (advanced ceramics,
advanced technical ceramics) —
Test method for air-purification
performance of semiconducting
photocatalytic materials —**

**Part 4:
Removal of formaldehyde**

(standards.iteh.ai)

*Céramiques techniques — Méthodes d'essai relatives à la performance
des matériaux photocatalytiques semi-conducteurs pour la
purification de l'air —*

<https://standards.iteh.ai/catalog/standards/siv/8528af-0ea4-4f8d-b583-18f2229b815/iso-22197-4-2013>

Partie 4: Élimination du formaldéhyde



iTeh STANDARD PREVIEW
(standards.iteh.ai)

[ISO 22197-4:2013](https://standards.iteh.ai/catalog/standards/sist/848528af-0ea4-4f8d-b583-18fb2229b8ba/iso-22197-4-2013)

<https://standards.iteh.ai/catalog/standards/sist/848528af-0ea4-4f8d-b583-18fb2229b8ba/iso-22197-4-2013>



COPYRIGHT PROTECTED DOCUMENT

© ISO 2013

All rights reserved. Unless otherwise specified, no part of this publication may be reproduced or utilized otherwise in any form or by any means, electronic or mechanical, including photocopying, or posting on the internet or an intranet, without prior written permission. Permission can be requested from either ISO at the address below or ISO's member body in the country of the requester.

ISO copyright office
Case postale 56 • CH-1211 Geneva 20
Tel. + 41 22 749 01 11
Fax + 41 22 749 09 47
E-mail copyright@iso.org
Web www.iso.org

Published in Switzerland

Contents

	Page
Foreword	iv
1 Scope	1
2 Normative references	1
3 Terms and definitions	1
4 Symbols	2
5 Principle	2
6 Apparatus	3
6.1 Test equipment	3
6.2 Test gas supply	5
6.3 Photoreactor	6
6.4 Light source	6
6.5 Analytical system	6
7 Test piece	6
8 Procedure	6
8.1 General aspects	6
8.2 Pretreatment of test piece	7
8.3 Preparation for the test	7
8.4 Pretest	8
8.5 Removal test	8
9 Calculation	8
10 Test method for test pieces with lower performance	9
11 Test report	9
Bibliography	10

iTech STANDARD PREVIEW

(standards.iteh.ai)

[ISO 22197-4:2013](https://standards.iteh.ai/catalog/standards/sis/848528af-0ca4-4f8d-b583-18fb2229b8ba/iso-22197-4-2013)

<https://standards.iteh.ai/catalog/standards/sis/848528af-0ca4-4f8d-b583-18fb2229b8ba/iso-22197-4-2013>

Foreword

ISO (the International Organization for Standardization) is a worldwide federation of national standards bodies (ISO member bodies). The work of preparing International Standards is normally carried out through ISO technical committees. Each member body interested in a subject for which a technical committee has been established has the right to be represented on that committee. International organizations, governmental and non-governmental, in liaison with ISO, also take part in the work. ISO collaborates closely with the International Electrotechnical Commission (IEC) on all matters of electrotechnical standardization.

International Standards are drafted in accordance with the rules given in the ISO/IEC Directives, Part 2.

The main task of technical committees is to prepare International Standards. Draft International Standards adopted by the technical committees are circulated to the member bodies for voting. Publication as an International Standard requires approval by at least 75 % of the member bodies casting a vote.

Attention is drawn to the possibility that some of the elements of this document may be the subject of patent rights. ISO shall not be held responsible for identifying any or all such patent rights.

ISO 22197-4 was prepared by Technical Committee ISO/TC 206, *Fine ceramics*.

ISO 22197 consists of the following parts, under the general title *Fine ceramics (advanced ceramics, advanced technical ceramics) — Test method for air-purification performance of semiconducting photocatalytic materials*:

- Part 1: Removal of nitric oxide
- Part 2: Removal of acetaldehyde
- Part 3: Removal of toluene
- Part 4: Removal of formaldehyde
- Part 5: Removal of methyl mercaptan

iTeh STANDARD PREVIEW
(standards.iteh.ai)

[ISO 22197-4:2013](https://standards.iteh.ai/catalog/standards/sist/848528af-0ea4-4f8d-b583-18fb2229b8ba/iso-22197-4-2013)

<https://standards.iteh.ai/catalog/standards/sist/848528af-0ea4-4f8d-b583-18fb2229b8ba/iso-22197-4-2013>

Fine ceramics (advanced ceramics, advanced technical ceramics) — Test method for air-purification performance of semiconducting photocatalytic materials —

Part 4: Removal of formaldehyde

1 Scope

This part of ISO 22197 specifies a test method for the determination of the air-purification performance of materials that contain a photocatalyst or have photocatalytic films on the surface, usually made from semiconducting metal oxides, such as titanium dioxide or other ceramic materials, by continuous exposure of a test piece to the model air pollutant under illumination with ultraviolet light (UV-A). This part of ISO 22197 is intended for use with different kinds of materials, such as construction materials in flat sheet, board or plate shape, that are the basic forms of materials for various applications. This part of ISO 22197 also applies to structured filter materials including honeycomb-form, woven and non-woven fabrics, and to plastic or paper materials if they contain ceramic microcrystals and composites. This part of ISO 22197 does not apply to powder or granular photocatalytic materials.

This test method is usually applicable to photocatalytic materials produced for air purification. This method is not suitable for the determination of other performance attributes of photocatalytic materials, i.e. decomposition of water contaminants, self-cleaning, antifogging and antibacterial actions. It concerns the removal of formaldehyde.

[ISO 22197-4:2013](https://standards.iteh.ai/catalog/standards/sist/848528af-0ea4-4f8d-b583-18fb2229b8ba/iso-22197-4-2013)

<https://standards.iteh.ai/catalog/standards/sist/848528af-0ea4-4f8d-b583-18fb2229b8ba/iso-22197-4-2013>

2 Normative references

The following referenced documents are indispensable for the application of this document. For dated references, only the edition cited applies. For undated references, the latest edition of the referenced document (including any amendments) applies.

ISO 4892-3, *Plastics — Methods of exposure to laboratory light sources — Part 3: Fluorescent UV lamps*

ISO 6145-7:2001, *Gas analysis — Preparation of calibration gas mixtures using dynamic volumetric methods — Part 7: Thermal mass-flow controllers*

ISO 10677:2011, *Fine ceramics (advanced ceramics, advanced technical ceramics) — Ultraviolet light source for testing semiconducting photocatalytic materials*

ISO 16000-3:2001, *Indoor air — Part 3: Determination of formaldehyde and other carbonyl compounds — Active sampling method*

ISO/IEC 17025:2005, *General requirements for the competence of testing and calibration laboratories*

ISO 22197-1:2007, *Fine ceramics (advanced ceramics, advanced technical ceramics) — Test method for air-purification performance of semiconducting photocatalytic materials — Part 1: Removal of nitric oxide*

ISO 80000-1, *Quantities and units — Part 1: General*

3 Terms and definitions

For the purposes of this document, the following terms and definitions apply.

3.1 photocatalyst
substance that performs one or more functions based on oxidation and reduction reactions under photoirradiation, including decomposition and removal of air and water contaminants, deodorization, and antibacterial, self-cleaning and antifogging actions

3.2 photocatalytic materials
materials in which or on which the photocatalyst is added by coating, impregnation, mixing, etc

Note 1 to entry: Such photocatalytic materials are intended primarily for use as building and road construction materials to obtain the above-mentioned functions

3.3 zero-calibration gas
air that does not contain pollutants (i.e. in which common pollutants are below 0,01 µl/l)

Note 1 to entry: The zero-calibration gas is prepared from indoor air using a laboratory air purification system, or supplied as a synthetic air in a gas cylinder.

3.4 formaldehyde gas
gases of known concentrations used for test and calibration

3.5 test gas
mixture of air and pollutant(s) of known concentration prepared from a standard gas or a zero-calibration gas, to be used for the performance test of a photocatalytic material

Note 1 to entry: The flow rate, concentration, etc. are expressed at the standard state (0 °C, 101,3 kPa) and dry gas basis (exclusion of water vapour).

ISO 22197-4:2013
<https://standards.iteh.ai/catalog/standards/sist/848528af-0ea4-4f8d-b583-18fb2229b8ba/iso-22197-4-2013>

3.6 dark condition
test condition with no light illumination by the light source for testing and room lightings

Note 1 to entry: Usually the test gas is supplied for comparison with the illuminated reaction.

4 Symbols

For the purposes of this document, the following symbols apply.

- f the flow rate of test gas converted into that at the standard state (l/min, 0 °C, 101,3 kPa, dry gas basis)
- ϕ_F the volume fraction of formaldehyde at the reactor exit (µl/l)
- ϕ_{F0} the supply volume fraction of formaldehyde (µl/l)
- n_F the removal quantity, by test piece, of formaldehyde (µmol)
- R_F the removal percentage, by test piece, of formaldehyde (%)

5 Principle

This part of ISO 22197 concerns the development, comparison, quality assurance, characterization, reliability, and design data generation of photocatalytic materials. The method described is intended to obtain the air-purification performance of photocatalytic materials by exposing a test piece to model polluted air under irradiation by ultraviolet (UV-A) light. Formaldehyde (HCHO) is chosen

because it is a typical indoor air pollutant that causes the so-called sick-building syndrome. The test piece, placed in a flow-type photoreactor, is activated by UV irradiation, and adsorbs and oxidizes gas-phase formaldehyde to form carbon dioxide (CO₂) and other oxidation products. The air purification performance is determined from the net amount of formaldehyde removed by the test piece (μmol). The simple adsorption of HCHO by the test piece (not due to photocatalysis) is evaluated by tests in the dark. However, some test pieces absorb formaldehyde very strongly, and a stable concentration of formaldehyde may not be attained in the designated time of test. The photocatalytic activity may depend on physical and chemical properties of pollutants mainly due to the adsorption process involved. For a better evaluation of air purification performance of photocatalytic materials, it is recommended to combine one or more suitable test methods as provided in other parts of ISO 22197.

6 Apparatus

6.1 Test equipment

The test equipment enables a photocatalytic material to be examined for its pollutant-removal capability by supplying the the test gas continuously, while providing photoirradiation to activate the photocatalyst. It is the same as that used in the test method for the removal of nitric oxide (ISO 22197-1) and consists of a test gas supply, a photoreactor, a light source, and pollutant-measurement equipment. Since low concentrations of pollutants are to be tested, the system shall be constructed with materials of low absorption and resistant to ultraviolet (UV) radiation, for example, acrylic resin, stainless steel, glass and fluorocarbon polymers. An example of a test system is shown in [Figure 1](#).

iTeh STANDARD PREVIEW (standards.iteh.ai)

[ISO 22197-4:2013](#)

<https://standards.iteh.ai/catalog/standards/sist/848528af-0ea4-4f8d-b583-18fb2229b8ba/iso-22197-4-2013>

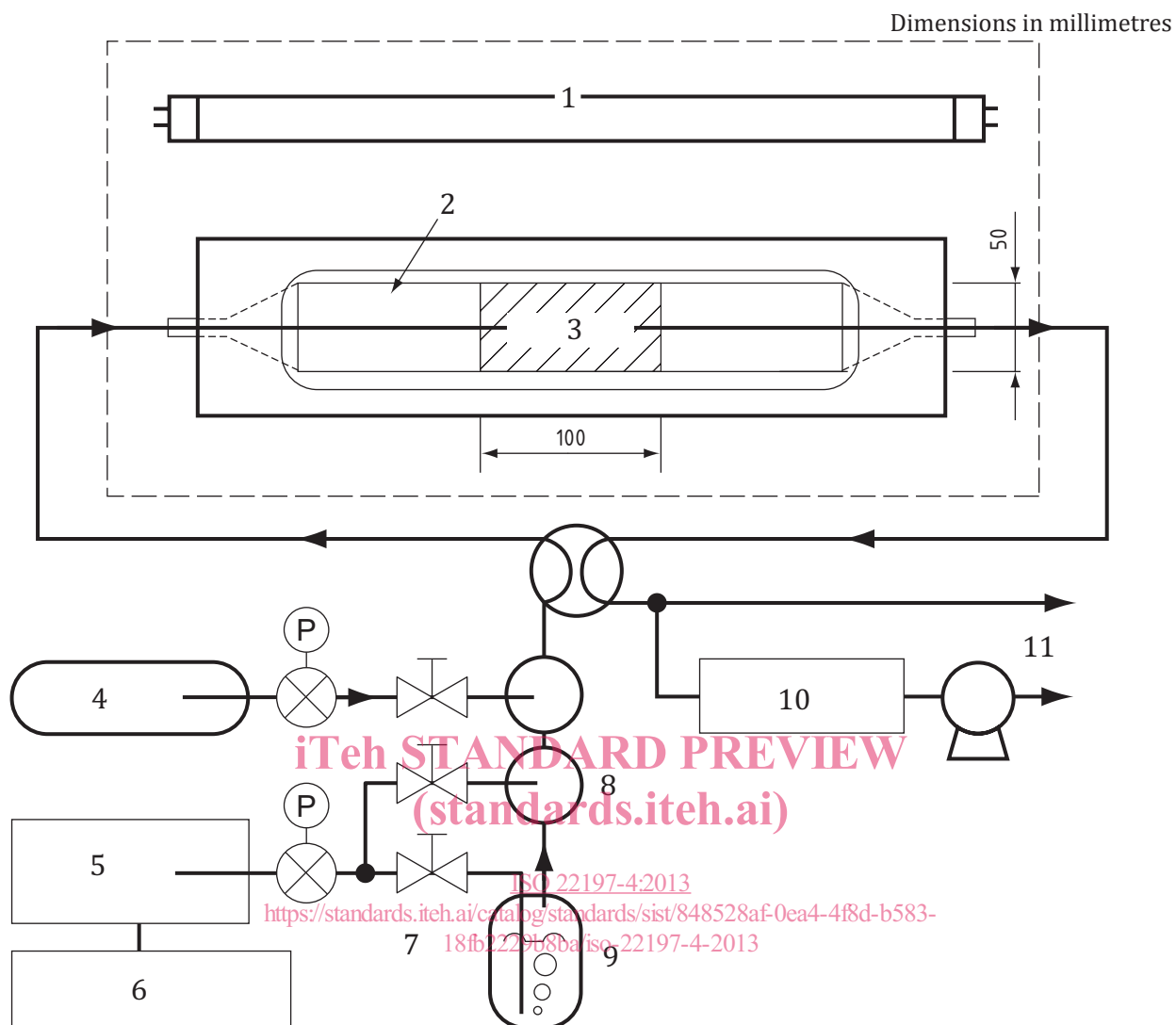

Key

- | | |
|----------------------------|------------------------|
| 1 light source | 7 mass-flow controller |
| 2 optical window | 8 gas mixers |
| 3 test piece | 9 humidifier |
| 4 standard gas (pollutant) | 10 analyser |
| 5 air-purification system | 11 vent |
| 6 compressor | |

Figure 1 — Schematic diagram of the test equipment

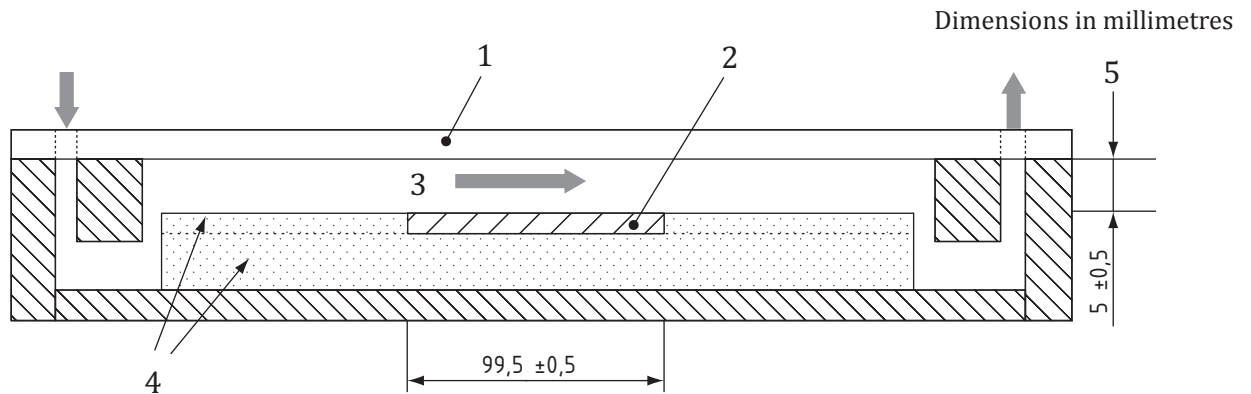

a) For flat test pieces

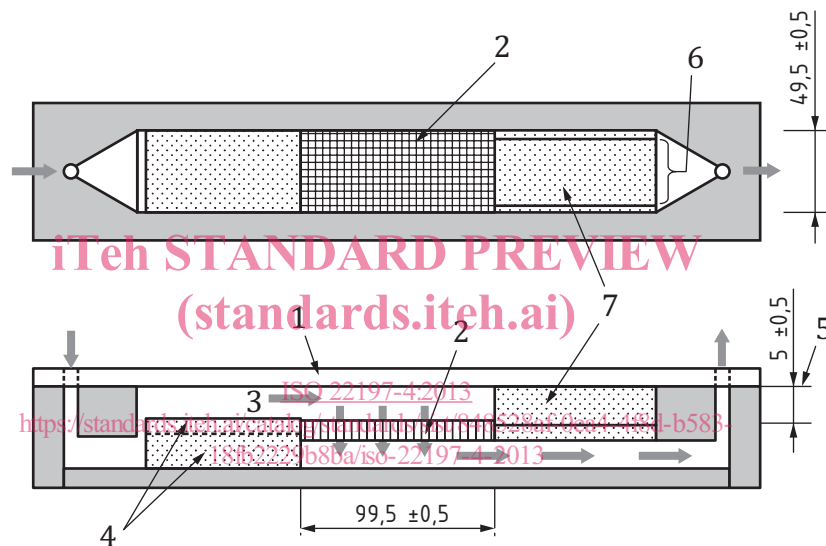

b) For filter-type test pieces

Key

- 1 window
- 2 test piece
- 3 test gas
- 4 height-adjusting plate
- 5 air layer thickness
- 6 flow channel
- 7 test piece holder

Figure 2 — Cross-sectional views of photoreactor (axial)**6.2 Test gas supply**

The test gas supply provides air polluted with model contaminant at a predetermined concentration, temperature and humidity, and supplies it continuously to the photoreactor. It consists of flow regulators, a humidifier, gas mixers, etc. The flow rate of each gas should be within 5 % of the designated value,