**Rubber, vulcanized or thermoplastic —
Determination of tensile stress-strain
properties**

*Caoutchouc vulcanisé ou thermoplastique — Détermination des
caractéristiques de contrainte-déformation en traction*

iTeh STANDARD PREVIEW
(standards.iteh.ai)

[ISO 37:2011](#)

<https://standards.iteh.ai/catalog/standards/sist/a26b15cc-3bcf-43f9-8a41-bce090a60e31/iso-37-2011>



iTeh STANDARD PREVIEW (standards.iteh.ai)

ISO 37:2011

<https://standards.iteh.ai/catalog/standards/sist/a26b15cc-3bcf-43f9-8a41-bce090a60e31/iso-37-2011>



COPYRIGHT PROTECTED DOCUMENT

© ISO 2011

All rights reserved. Unless otherwise specified, no part of this publication may be reproduced or utilized in any form or by any means, electronic or mechanical, including photocopying and microfilm, without permission in writing from either ISO at the address below or ISO's member body in the country of the requester.

ISO copyright office
Case postale 56 • CH-1211 Geneva 20
Tel. + 41 22 749 01 11
Fax + 41 22 749 09 47
E-mail copyright@iso.org
Web www.iso.org

Published in Switzerland

Contents

Page

Foreword	iv
1 Scope	1
2 Normative references	1
3 Terms and definitions	1
4 Principle	4
5 General	4
6 Test pieces	5
7 Apparatus	6
8 Number of test pieces	9
9 Preparation of test pieces	10
10 Conditioning of sample and test pieces	10
11 Marking of dumb-bell test pieces	11
12 Measurement of test pieces	11
13 Procedure	11
14 Temperature of test	12
15 Calculation of results	12
16 Expression of results	15
17 Precision	15
18 Test report	15
Annex A (informative) Preparation of type B ring test pieces	16
Annex B (informative) Precision	19
Annex C (informative) Analysis of ITP data and dumb-bell shape	23
Bibliography	27

Foreword

ISO (the International Organization for Standardization) is a worldwide federation of national standards bodies (ISO member bodies). The work of preparing International Standards is normally carried out through ISO technical committees. Each member body interested in a subject for which a technical committee has been established has the right to be represented on that committee. International organizations, governmental and non-governmental, in liaison with ISO, also take part in the work. ISO collaborates closely with the International Electrotechnical Commission (IEC) on all matters of electrotechnical standardization.

International Standards are drafted in accordance with the rules given in the ISO/IEC Directives, Part 2.

The main task of technical committees is to prepare International Standards. Draft International Standards adopted by the technical committees are circulated to the member bodies for voting. Publication as an International Standard requires approval by at least 75 % of the member bodies casting a vote.

Attention is drawn to the possibility that some of the elements of this document may be the subject of patent rights. ISO shall not be held responsible for identifying any or all such patent rights.

ISO 37 was prepared by Technical Committee ISO/TC 45, *Rubber and rubber products*, Subcommittee SC 2, *Testing and analysis*.

This fifth edition cancels and replaces the fourth edition (ISO 37:2005), which has been technically revised. It also incorporates the Technical Corrigendum ISO 37:2005/Cor.1:2008.

The technical changes mainly concern the testing of ring test pieces, which is now described in more detail.

<https://standards.iteh.ai/catalog/standards/sist/a26b15cc-3bcf-43f9-8a41-bce090a60e31/iso-37-2011>

Rubber, vulcanized or thermoplastic — Determination of tensile stress-strain properties

WARNING — Persons using this International Standard should be familiar with normal laboratory practice. This standard does not purport to address all of the safety problems, if any, associated with its use. It is the responsibility of the user to establish appropriate safety and health practices and to ensure compliance with any national regulatory conditions.

IMPORTANT — Certain procedures specified in this International Standard might involve the use or generation of substances, or the generation of waste, that could constitute a local environmental hazard. Reference should be made to appropriate documentation on safe handling and disposal after use.

1 Scope

This International Standard describes a method for the determination of the tensile stress-strain properties of vulcanized and thermoplastic rubbers.

The properties which can be determined are tensile strength, elongation at break, stress at a given elongation, elongation at a given stress, stress at yield and elongation at yield. The measurement of stress and strain at yield applies only to some thermoplastic rubbers and certain other compounds.

[ISO 37:2011](https://standards.iteh.ai/catalog/standards/sist/a26b15cc-3bcf-43f9-8a41-bce090a60e31/iso-37-2011)

<https://standards.iteh.ai/catalog/standards/sist/a26b15cc-3bcf-43f9-8a41-bce090a60e31/iso-37-2011>

2 Normative references

The following referenced documents are indispensable for the application of this document. For dated references, only the edition cited applies. For undated references, the latest edition of the referenced document (including any amendments) applies.

ISO 5893, *Rubber and plastics test equipment — Tensile, flexural and compression types (constant rate of traverse) — Specification*

ISO 23529:2010, *Rubber — General procedures for preparing and conditioning test pieces for physical test methods*

3 Terms and definitions

For the purposes of this document, the following terms and definitions apply.

3.1

tensile stress

S

stress applied so as to extend the test piece

NOTE It is calculated as the applied force per unit area of the original cross-section of the test length.

**3.2
elongation**

E
tensile strain, expressed as a percentage of the test length, produced in the test piece by a tensile stress

**3.3
tensile strength**

TS
maximum tensile stress recorded in extending the test piece to breaking point

NOTE See Figures 1a) to 1c).

**3.4
tensile strength at break**

TS_b
tensile stress recorded at the moment of rupture

NOTE 1 See Figures 1a) to 1c).

NOTE 2 The values of TS and TS_b might be different if, after yield at S_y , the elongation continues and is accompanied by a drop in stress, resulting in TS_b being lower than TS [see Figure 1c)].

**3.5
elongation at break**

E_b
tensile strain in the test length at breaking point

NOTE See Figures 1a) to 1c).

**3.6
elongation at a given stress**

E_s
tensile strain in the test length when the test piece is subjected to a given tensile stress

ITEH STANDARD PREVIEW
(standards.iteh.ai)

ISO 37:2011

[https://standards.iteh.ai/catalog/standards/sist/a26b15cc-3bcf-43f9-8a41-](https://standards.iteh.ai/catalog/standards/sist/a26b15cc-3bcf-43f9-8a41-40c0c0c0c0c0)

[40c0c0c0c0c0](https://standards.iteh.ai/catalog/standards/sist/a26b15cc-3bcf-43f9-8a41-40c0c0c0c0c0)

**3.7
stress at a given elongation**

S_e
tensile stress in the test length required to produce a given elongation

NOTE In the rubber industry, this definition is widely identified with the term “modulus” and care should be taken to avoid confusion with the other use of “modulus” to denote the slope of the stress-strain curve at a given elongation.

**3.8
tensile stress at yield**

S_y
tensile stress at the first point on the stress-strain curve where some further increase in strain occurs without any increase in stress

NOTE This might correspond either to a point of inflection [see Figure 1b)] or to a maximum [see Figure 1c)].

**3.9
elongation at yield**

E_y
tensile strain at the first point on the stress-strain curve where some further increase in strain is not accompanied by an increase in stress

NOTE See Figures 1b) and 1c).

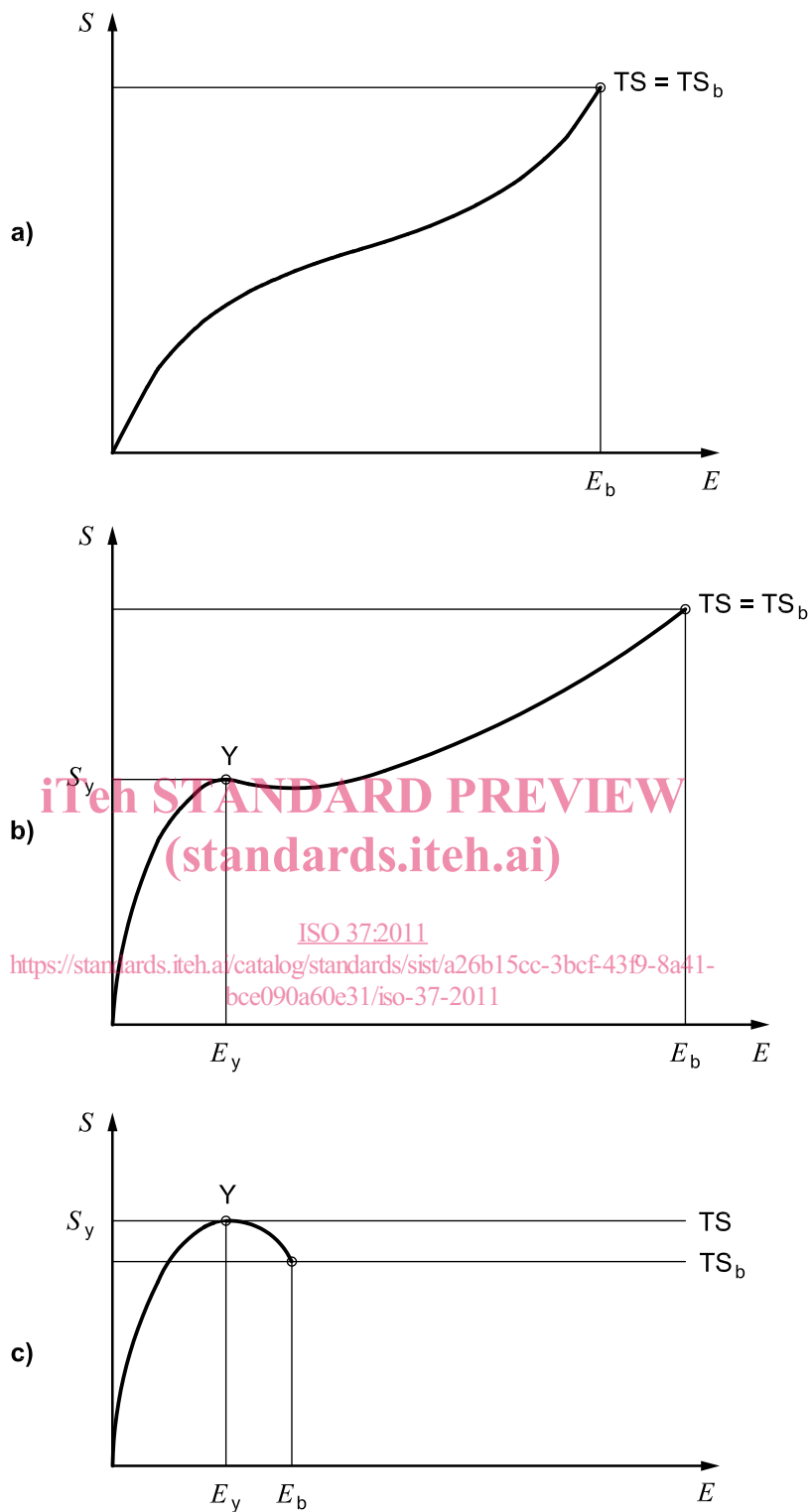

Key

- | | | | |
|-------|---------------------|--------|---------------------------|
| E | elongation | S_y | stress at yield |
| E_b | elongation at break | TS | tensile strength |
| E_y | elongation at yield | TS_b | tensile strength at break |
| S | stress | Y | yield point |

Figure 1 — Illustration of tensile terms

3.10
test length of a dumb-bell

initial distance between reference points within the length of the narrow portion of a dumb-bell test piece used to measure elongation

NOTE See Figure 2.

4 Principle

Standard test pieces, either dumb-bells or rings, are stretched in a tensile-testing machine at a constant rate of traverse of the driven grip or pulley. Readings of force and elongation are taken as required during the uninterrupted stretching of the test piece and when it breaks.

5 General

Dumb-bell and ring test pieces do not necessarily give the same values for their respective stress-strain properties. This is mainly because in stretched rings the stress is not uniform over the cross-section. A second factor is in the existence of "grain" which might cause dumb-bells to give different values depending on whether their length is parallel or at right angles to the grain.

The main points to be noted in choosing between rings and dumb-bells are as follows:

a) Tensile strength

Dumb-bells are preferable for determination of tensile strength. Rings give lower, sometimes much lower, values than dumb-bells.

b) Elongation at break

Rings give approximately the same values as dumb-bells, provided that

- 1) the elongation of rings is calculated as a percentage of the initial internal circumference and
- 2) dumb-bells are cut at right angles to the grain if this is present to a significant degree.

Dumb-bells shall be used if it is required to study grain effects, as rings are not suitable for this purpose.

c) Elongation at a given stress and stress at a given elongation

The larger dumb-bells (types 1, 2 and 1A) are generally preferred.

Rings and dumb-bells give approximately the same values provided that

- 1) the elongation of rings is calculated as a percentage of the initial mean circumference and
- 2) the average value is taken for dumb-bells cut parallel and at right angles to the grain if this is present to a significant degree.

Rings might be preferred in automated testing, due to the ease of handling of the test pieces, and in the determination of stress at a given strain.

6 Test pieces

6.1 General

Miniature test pieces might give somewhat different, usually higher, values for tensile strength and elongation at break than the larger test pieces.

Seven types of test piece are provided, i.e. dumb-bell-shaped types 1, 2, 3, 4 and 1A and ring-shaped types A (normal) and B (miniature). The results obtained for a given material are likely to vary according to the type of test piece used, and the results obtained for different materials should therefore not be regarded as comparable unless the same type of test piece has been used.

When preparation of test pieces requires buffing or thickness adjustment, results might be affected.

6.2 Dumb-bells

Dumb-bell test pieces shall have the outline shown in Figure 2.

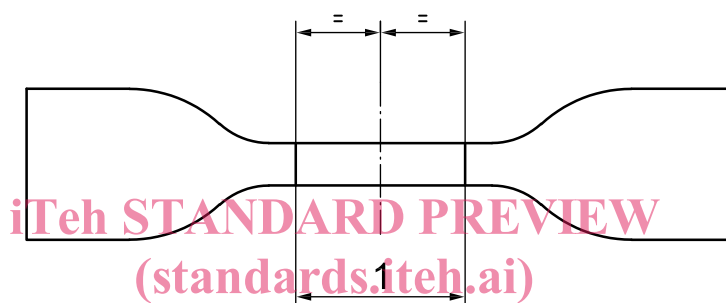

ISO 37:2011

Key

1 test length (see Table 1)

<https://standards.1teh.ai/catalog/standards/sist/a26b15cc-3bcf-43f9-8a41-bce090a60e31/iso-37-2011>

Figure 2 — Shape of dumb-bell test pieces

The standard thickness of the narrow portion shall be 2,0 mm ± 0,2 mm for types 1, 2, 3 and 1A and 1,0 mm ± 0,1 mm for type 4.

The test length shall be in accordance with Table 1.

The other dimensions of the dumb-bells shall be as produced by the appropriate die (see Table 2).

For non-standard test pieces, e.g. those taken from finished products, the maximum thickness of the narrow portion shall be 3,0 mm for types 1 and 1A, 2,5 mm for types 2 and 3, and 2,0 mm for type 4.

Table 1 — Test length of dumb-bells

Type of test piece	Type 1	Type 1A	Type 2	Type 3	Type 4
Test length (mm)	25 ± 0,5	20 ± 0,5 ^a	20 ± 0,5	10 ± 0,5	10 ± 0,5
^a The test length shall not exceed the length of the narrow portion of the test piece (dimension C in Table 2).					

Type 3 and 4 dumb-bell test pieces shall only be used where insufficient material is available for the larger test pieces. These test pieces are particularly suitable for testing products and are used in certain product standards, e.g. type 3 dumb-bells have been used for testing pipe sealing rings and cable coverings.

6.3 Rings

The standard type A ring test piece shall have an internal diameter of 44,6 mm ± 0,2 mm. The median axial thickness and median radial width shall be 4 mm ± 0,2 mm. The radial width of any ring shall nowhere deviate from the median by more than 0,2 mm and the axial thickness of the ring shall nowhere deviate from the median by more than 2 %.

The standard type B ring test piece shall have an internal diameter of 8 mm ± 0,1 mm. The median axial thickness and median radial width shall be 1 mm ± 0,1 mm. The radial width of any ring shall nowhere deviate from the median by more than 0,1 mm. This test piece shall be used only where insufficient material is available for the larger type A test piece.

7 Apparatus

7.1 Dies and cutters

All dies and cutters used shall be in accordance with ISO 23529. Dies for preparation of dumb-bells shall have the dimensions given in Table 2 and Figure 3 except for the cutting edge for which Figure 3 only indicates a suitable geometry. The departure from parallelism at any point along the width of the narrow portion of the die shall nowhere exceed 0,05 mm.

For a method of cutting type B ring test pieces, see Annex A.

Table 2 — Dimensions of dies for dumb-bell test pieces

Dimension	Type 1	Type 1A	Type 2	Type 3	Type 4
A Overall length (minimum) ^a (mm)	115	100	75	50	35
B Width of ends (mm)	25 ± 1	25 ± 1	12,5 ± 1	8,5 ± 0,5	6 ± 0,5
C Length of narrow portion (mm)	33 ± 2	21 ± 1	25 ± 1	16 ± 1	12 ± 0,5
D Width of narrow portion (mm)	6,2 ± 0,2	5 ± 0,1	4 ± 0,1	4 ± 0,1	2 ± 0,1
E Transition radius outside (mm)	14 ± 1	11 ± 1	8 ± 0,5	7,5 ± 0,5	3 ± 0,1
F Transition radius inside (mm)	25 ± 2	25 ± 2	12,5 ± 1	10 ± 0,5	3 ± 0,1

^a A greater overall length might be necessary to ensure that only the wide end tabs come into contact with the machine grips, thus avoiding "shoulder breaks".

7.2 Thickness gauge

The instrument for measuring the thickness of dumb-bell test pieces and the axial thickness of ring test pieces shall be in accordance with that used in method A of ISO 23529:2010.

The instrument for measuring the radial width of ring test pieces shall be similar to the above, except that the contact and base plate shall be shaped to fit the curvature of the ring.

7.3 Cone gauge

A calibrated cone gauge or other suitable equipment shall be used to measure the internal diameter of ring test pieces. The equipment shall be capable of measuring the diameter with an error of not more than 0,01 mm. The means of supporting the ring test piece to be measured shall be such as to avoid any significant change in the dimension being measured.

Dimensions in millimetres

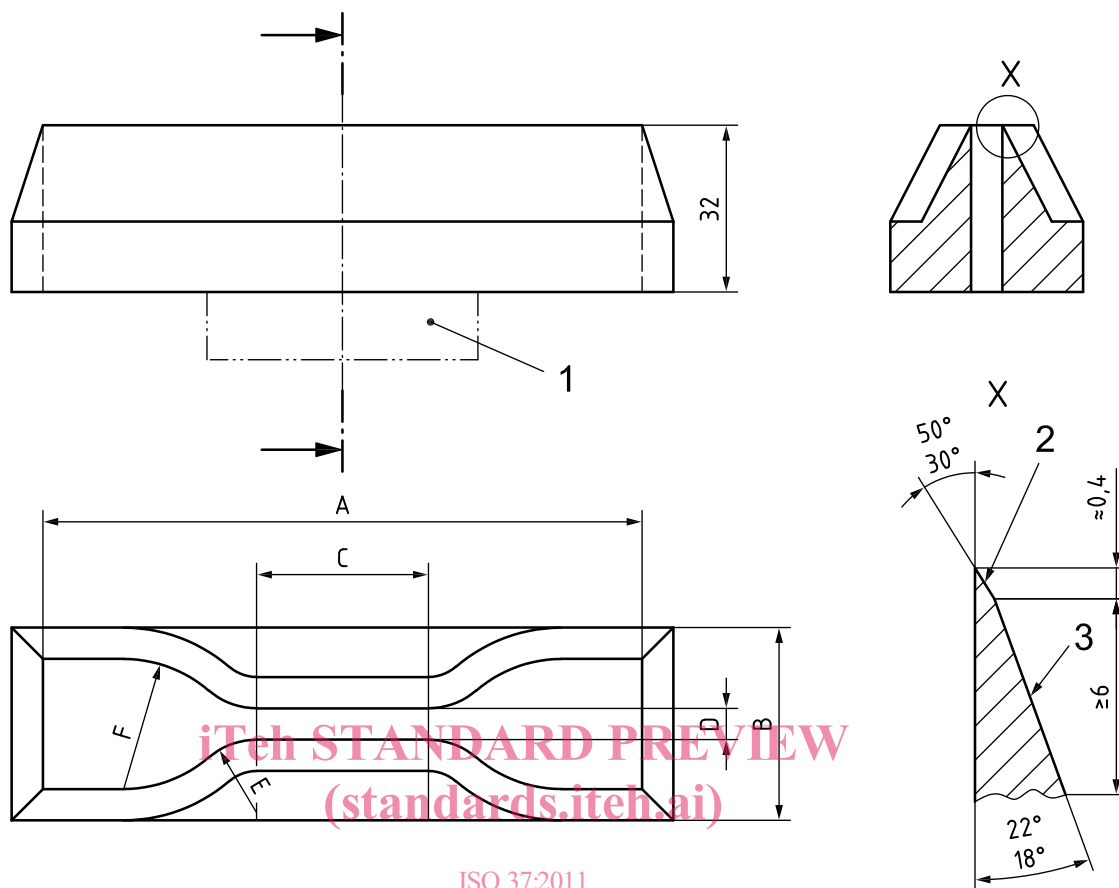

ISO 37:2011

<https://standards.iteh.ai/catalog/standards/sist/a26b15cc-3bcf-43f9-8a41-bce090a60e31/iso-37-2011>

Key

- 1 method of fixing to suit machine
- 2 ground smooth
- 3 ground

NOTE 1 For dimensions A to F, see Table 2.

NOTE 2 The diagrams on the right show sections of typical fixed blades.

Figure 3 — Die for dumb-bell test pieces

7.4 Tensile-testing machine

7.4.1 The tensile-testing machine shall comply with the requirements of ISO 5893, having an accuracy of force measurement complying with class 2. An extensometer, where used, shall have an accuracy complying with class D for type 1, 1A and 2 dumb-bell test pieces and class E for type 3 and 4 dumb-bell test pieces. The machine shall, as a minimum, be capable of operating at rates of traverse of 100 mm/min, 200 mm/min and 500 mm/min.

When testing dumb-bells, the method of measuring the extension might require the test machine to apply a small prestress to the test piece to avoid it bending. In this case, the machine shall be capable of applying the necessary prestress.

7.4.2 For tests at temperatures other than a standard laboratory temperature, a suitable thermostatically controlled chamber shall be fitted to the tensile-testing machine. Guidance for achieving elevated or subnormal temperatures is given in ISO 23529.

7.5 Test rig for ring test pieces

An example of a test rig using pulleys for testing rings is shown in Figure 4. For rings of types A and B, the pulley dimensions shall be as specified in Table 3 and Figure 5.

One of the pulleys shall be free to turn with very low friction and the other shall be driven to rotate the ring. It shall run at a speed between 10 rpm and 15 rpm.

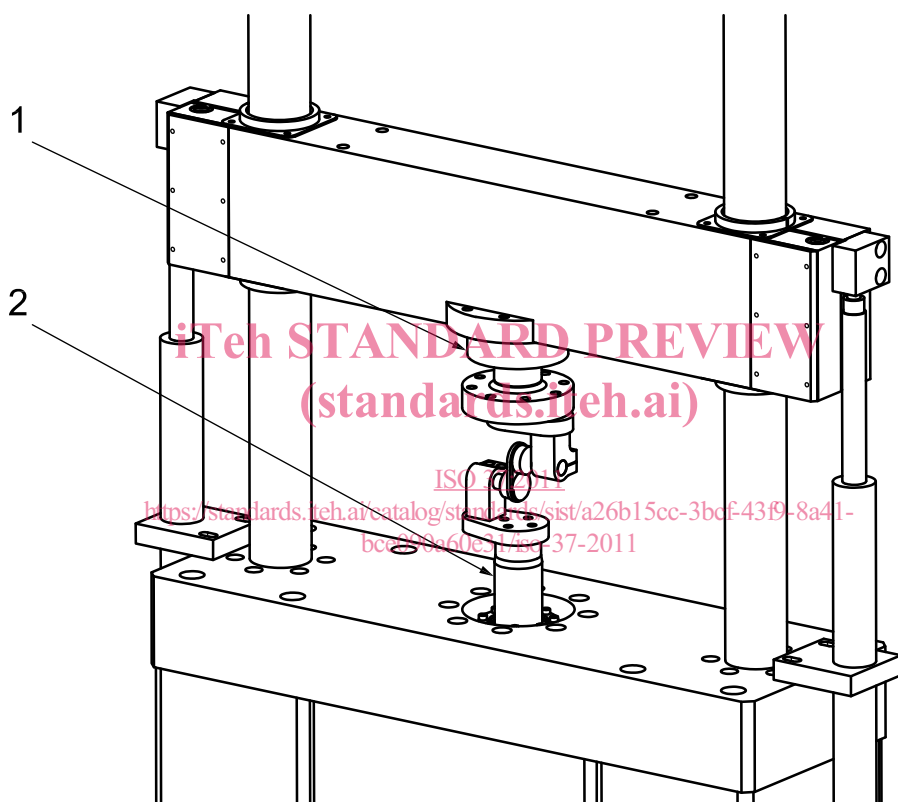

Key

- 1 load cell
- 2 actuator

Figure 4 — Example of rig for tensile tests on rings