**Rubber, vulcanized or thermoplastic —
Determination of flex cracking and crack
growth (De Mattia)**

*Caoutchouc vulcanisé ou thermoplastique — Détermination de la
résistance au développement d'une craquelure (De Mattia)*

iTeh STANDARD PREVIEW
(standards.iteh.ai)

ISO 132:2011

<https://standards.iteh.ai/catalog/standards/sist/f7c30b8d-9291-4ccf-8696-60b75cd6ab6b/iso-132-2011>

iTeh STANDARD PREVIEW (standards.iteh.ai)

ISO 132:2011

<https://standards.iteh.ai/catalog/standards/sist/f7c30b8d-9291-4ccf-8696-60b75cd6ab6b/iso-132-2011>



COPYRIGHT PROTECTED DOCUMENT

© ISO 2011

All rights reserved. Unless otherwise specified, no part of this publication may be reproduced or utilized in any form or by any means, electronic or mechanical, including photocopying and microfilm, without permission in writing from either ISO at the address below or ISO's member body in the country of the requester.

ISO copyright office
Case postale 56 • CH-1211 Geneva 20
Tel. + 41 22 749 01 11
Fax + 41 22 749 09 47
E-mail copyright@iso.org
Web www.iso.org

Published in Switzerland

Contents

Page

Foreword	iv
Introduction.....	v
1 Scope	1
2 Normative references	1
3 Apparatus	1
4 Calibration	2
5 Test pieces	2
5.1 Shape, dimensions and preparation	2
5.2 Preparation of test pieces for crack growth measurement.....	3
5.3 Time interval between vulcanization and testing.....	5
5.4 Conditioning	5
5.5 Number of test pieces	5
6 Test conditions	5
6.1 Temperature	5
6.2 Humidity	5
7 Procedure	5
7.1 General	5
7.2 Determination of flex cracking	6
7.3 Determination of crack growth	6
8 Expression of results	6
8.1 Determination of flex cracking	6
8.2 Determination of crack growth	7
9 Precision	7
10 Test report.....	7
Annex A (normative) Calibration schedule	9
Annex B (informative) Precision.....	11
Bibliography.....	15

Foreword

ISO (the International Organization for Standardization) is a worldwide federation of national standards bodies (ISO member bodies). The work of preparing International Standards is normally carried out through ISO technical committees. Each member body interested in a subject for which a technical committee has been established has the right to be represented on that committee. International organizations, governmental and non-governmental, in liaison with ISO, also take part in the work. ISO collaborates closely with the International Electrotechnical Commission (IEC) on all matters of electrotechnical standardization.

International Standards are drafted in accordance with the rules given in the ISO/IEC Directives, Part 2.

The main task of technical committees is to prepare International Standards. Draft International Standards adopted by the technical committees are circulated to the member bodies for voting. Publication as an International Standard requires approval by at least 75 % of the member bodies casting a vote.

Attention is drawn to the possibility that some of the elements of this document may be the subject of patent rights. ISO shall not be held responsible for identifying any or all such patent rights.

ISO 132 was prepared by Technical Committee ISO/TC 45, *Rubber and rubber products*, Subcommittee SC 2, *Testing and analysis*.

This fifth edition cancels and replaces the fourth edition (ISO 132:2005), of which it constitutes a minor revision the main purpose of which was to add Annex A concerning calibration and Annex B with precision results.

iTeh STANDARD PREVIEW
(standards.iteh.ai)
ISO 132:2011
<https://standards.iteh.ai/catalog/standards/sist/f7c30b8d-9291-4ccf-8696-60b75cd6ab6b/iso-132-2011>

Introduction

Repeated bending or flexing of a rubber causes cracks to develop in that part of the surface where tension stress is set up during flexing or, if this part of the surface contains a crack, causes this crack to extend in a direction perpendicular to the stress. Certain soft vulcanizates, for instance those prepared from styrene-butadiene rubber, show marked resistance to crack initiation, but it is possible for these vulcanizates to have a low resistance to growth (propagation) of cracks. It is important, therefore, to measure both the resistance to crack initiation by flexing and the resistance to crack propagation.

The method is suitable for rubbers that have reasonably stable stress-strain properties, at least after a period of cycling, and do not show undue stress softening or set, or highly viscous behaviour. The results obtained for some thermoplastic rubbers should be treated with caution if the elongation at yield is below, or close to, the maximum strain imposed during the test.

iTeh STANDARD PREVIEW (standards.iteh.ai)

ISO 132:2011

<https://standards.iteh.ai/catalog/standards/sist/f7c30b8d-9291-4ccf-8696-60b75cd6ab6b/iso-132-2011>

iTeh STANDARD PREVIEW
(standards.iteh.ai)

ISO 132:2011

<https://standards.iteh.ai/catalog/standards/sist/f7c30b8d-9291-4ccf-8696-60b75cd6ab6b/iso-132-2011>

Rubber, vulcanized or thermoplastic — Determination of flex cracking and crack growth (De Mattia)

WARNING — Persons using this International Standard should be familiar with normal laboratory practice. This standard does not purport to address all of the safety problems, if any, associated with its use. It is the responsibility of the user to establish appropriate safety and health practices and to ensure compliance with any national regulatory conditions.

IMPORTANT — Certain procedures specified in this International Standard might involve the use or generation of substances, or the generation of waste, that could constitute a local environmental hazard. Reference should be made to appropriate documentation on safe handling and disposal after use.

1 Scope

This International Standard specifies a method of test intended for use in comparing the resistance of vulcanized or thermoplastic rubbers to the formation and growth of cracks, when subjected to repeated flexing on the De Mattia type machine. For determination of crack growth, an artificial cut is made in the test piece to initiate cut growth.

2 Normative references

The following referenced documents are indispensable for the application of this document. For dated references, only the edition cited applies. For undated references, the latest edition of the referenced document (including any amendments) applies.

ISO 18899:2004, *Rubber — Guide to the calibration of test equipment*

ISO 23529, *Rubber — General procedures for preparing and conditioning test pieces for physical test methods*

3 Apparatus

3.1 De Mattia type machine, the essential features of which are as follows:

The machine has stationary parts, provided with grips for holding one end of each of the test pieces in a fixed position, and similar but reciprocating parts for holding the other end of each of the test pieces. The travel is $57^{+0,5}_0$ mm and is such that the maximum distance between each set of opposing grips is 75^{+1}_0 mm (see Figure 1).

The reciprocating parts are so arranged that their motion is straight and in the direction of, and in the same plane as, the common centreline of each opposing pair of grips. The planes of the gripping surfaces of each opposing pair of grips remain parallel throughout the motion.

The eccentric which actuates the reciprocating parts is driven by a constant-speed motor to give $5,00 \text{ Hz} \pm 0,17 \text{ Hz}$, with sufficient power to flex at least six, and preferably 12, test pieces at one test. The grips hold the test pieces firmly, without undue compression, and enable individual adjustment to be made to the test pieces to ensure accurate insertion.

It is useful to arrange the test pieces in two equal groups, so that one group is being flexed while the other group is being straightened, thus reducing the vibration in the machine.

For testing at elevated or subnormal temperatures, the machine can be enclosed in a chamber with temperature control near the centre of the test piece to $\pm 2\text{ }^\circ\text{C}$, if necessary, by using an air circulator.

3.2 Piercing tool and suitable jig, for piercing the test pieces (see 5.2).

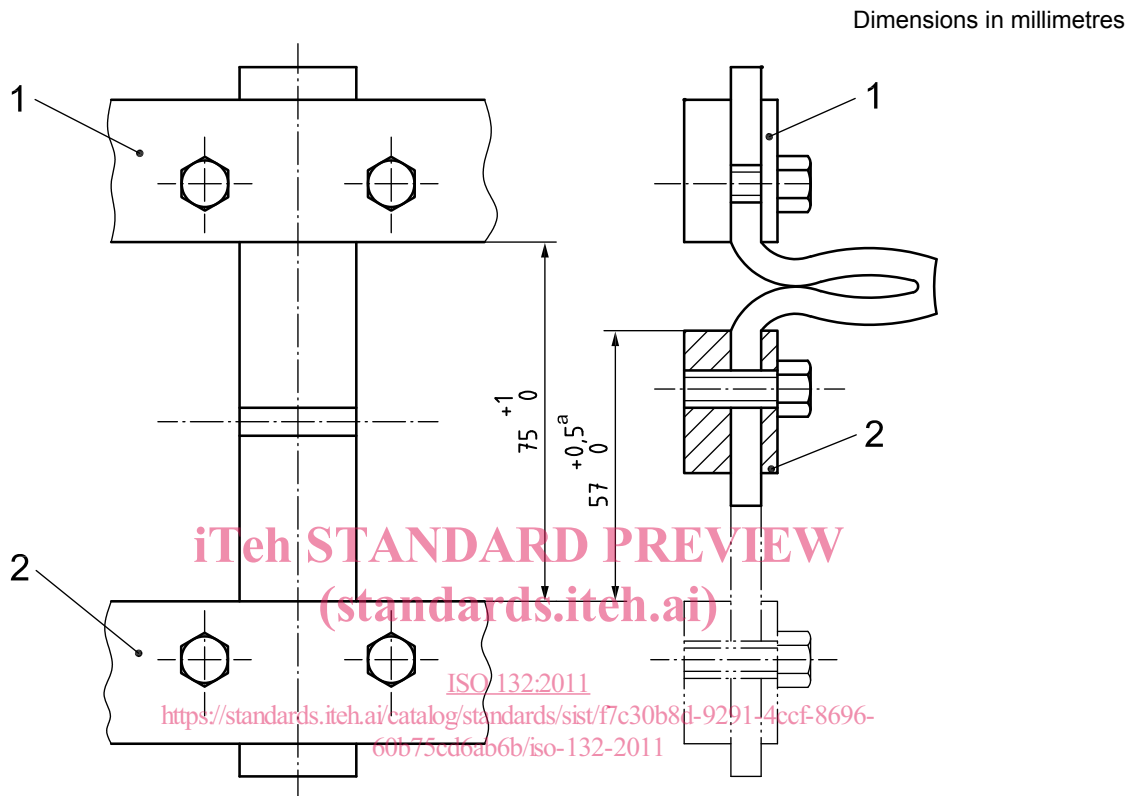

Key

- 1 upper grip
- 2 lower grip
- a Travel.

Figure 1 — De Mattia type machine

4 Calibration

The requirements for calibration of the test apparatus are given in Annex A.

5 Test pieces

5.1 Shape, dimensions and preparation

Each test piece shall be a strip with a moulded groove. The strips can be moulded individually in a multiple-cavity mould, as shown in Figure 2, or can be cut from a wide slab having a moulded groove.

The groove in the test piece shall have a smooth surface and be free from irregularities from which cracks can start prematurely. The groove shall be moulded into the test piece or slab by a half-round ridge in the centre of the cavity.

The half-round ridge shall have a radius of $2,38 \text{ mm} \pm 0,03 \text{ mm}$. The moulded groove shall be perpendicular to the direction of mill grain.

Results can be compared only between test pieces having thicknesses, measured close to the groove, which are within the tolerances, because the results of the test are dependent upon the thickness of the test piece.

If finished products are to be tested, test pieces without a groove can be used. They shall be prepared in accordance with ISO 23529. Cracks shall not be assessed on surfaces that have been cut or buffed. The use of test pieces cut and/or buffed from finished products shall be stated in the test report.

Dimensions in millimetres

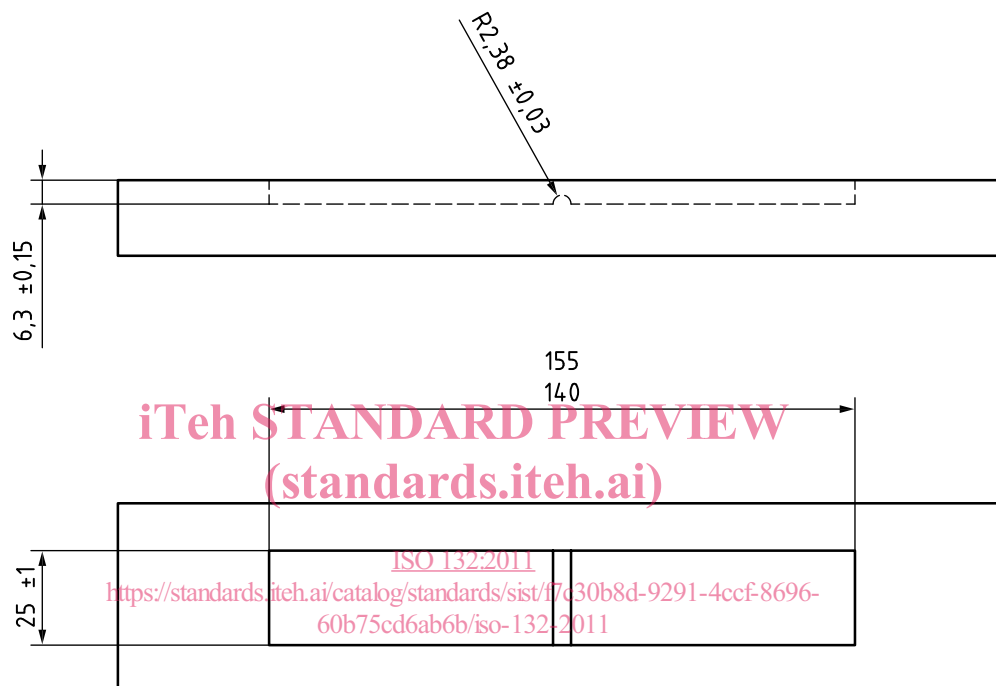

Figure 2 — Form for moulding test piece

5.2 Preparation of test pieces for crack growth measurement

Each test piece shall be prepared by piercing the bottom of the groove at a point equidistant from the sides, using a suitable jig. The piercing tool shall conform to the dimensions given in Figure 3. The piercing tool shall be maintained perpendicular to both the transverse and longitudinal axes, and the cut accomplished by a single insertion and withdrawal of the tool. The cut shall be parallel to the longitudinal axis of the groove. Lubrication with water containing a suitable wetting agent can be used.

A suitable jig shall be provided to hold the piercing tool; the exact details are not specified but the principles of operation shall be as follows:

The test piece shall be held flat in a solid support. The piercing tool shall be normal to the support and placed centrally with respect to the groove in the test piece, with the cutting edge of the piercing tool parallel to the axis of the groove. Means shall be provided for passing the piercing tool through the entire thickness of the rubber, and the support shall have a hole of a size just sufficient to permit the piercing tool to project through the base of the test piece to not less than 2,5 mm and not more than 3 mm.

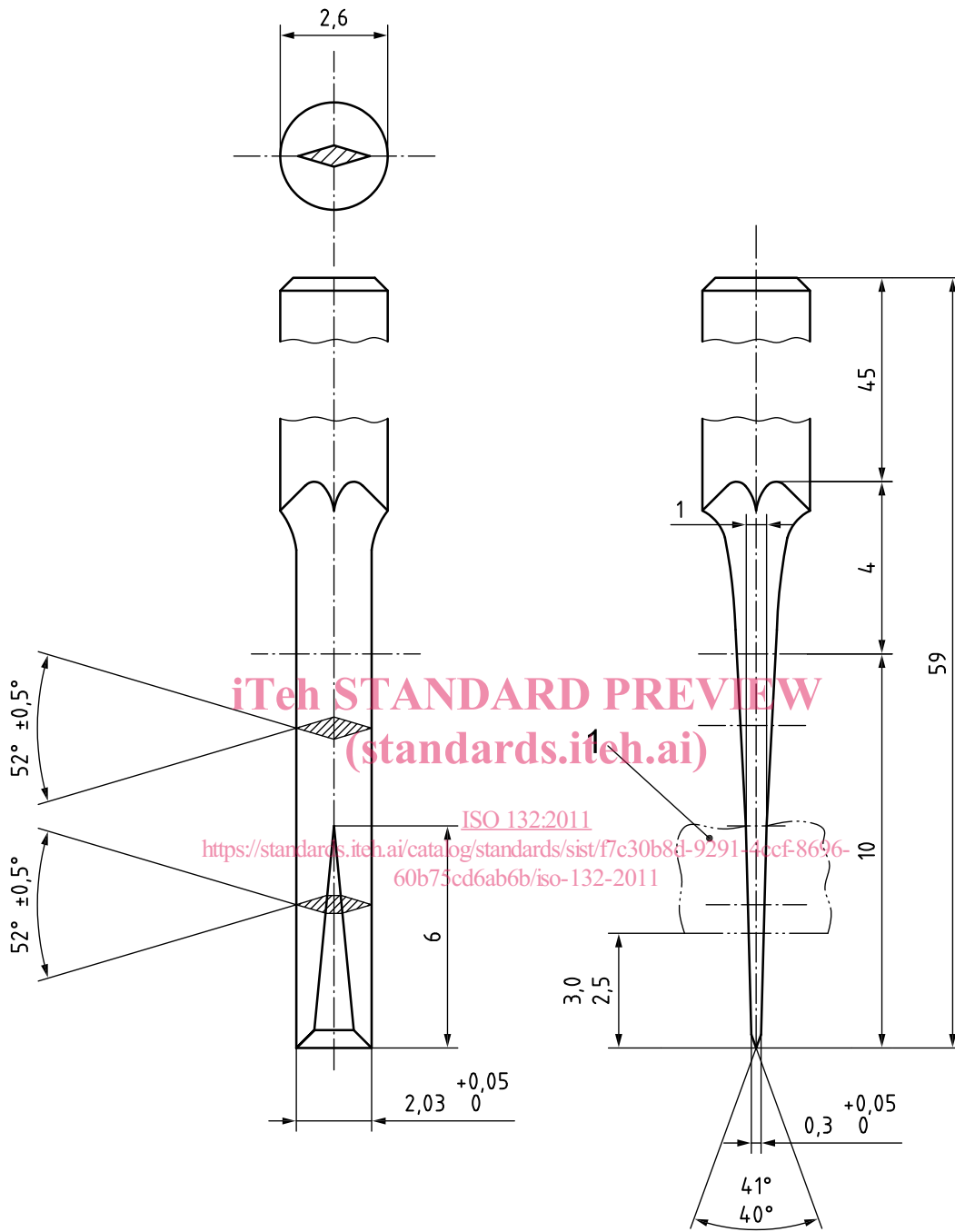

Key

- 1 test piece

Figure 3 — Piercing tool

5.3 Time interval between vulcanization and testing

For all test purposes, the minimum time between vulcanization and testing shall be 16 h in accordance with ISO 23529.

For non-product tests, the maximum time between vulcanization and testing shall be 4 weeks and, for evaluations intended to be comparable, the tests shall, as far as possible, be carried out after the same time interval.

As far as possible, samples and test pieces shall be kept away from exposure to light.

5.4 Conditioning

For tests under standard laboratory conditions (see Clause 6), individually moulded test pieces shall be conditioned under the test conditions for a period of time in accordance with ISO 23529 immediately before testing.

Slab samples shall be similarly conditioned before the test pieces are cut. These test pieces can be either tested immediately or kept at the test temperature until tested.

For tests at other temperatures (see Clause 6), after the conditioning period specified above the test pieces shall be brought to the test temperature by keeping in a chamber at this temperature for 3 h, then tested immediately (see ISO 23529).

The same test temperature shall be used throughout any test or series of tests intended to be comparable.

5.5 Number of test pieces (standards.iteh.ai)

At least three, and preferably six, test pieces from each rubber compound shall be tested. If comparison is required between different compounds, ensure that test pieces of each compound are mounted at the same time on the same test machine.

6 Test conditions

6.1 Temperature

Tests are normally performed at a standard laboratory temperature as defined in ISO 23529, although elevated or subnormal temperatures can often be used to advantage. In the latter case, the test temperature shall be selected from ISO 23529.

6.2 Humidity

With compounds where the results are known to be sensitive to humidity, the test shall be carried out under standard laboratory conditions (temperature and humidity) as defined in ISO 23529.

NOTE An influence of humidity has been observed with fluororubbers, polyurethane rubbers and other rubbers containing hydrophilic fillers.

7 Procedure

7.1 General

The presence of significant amounts of ozone in the laboratory atmosphere affects the results. Periodic checks are advised to ensure that the ambient ozone concentration is preferably less than 1 part by volume per 100 million parts of air.