

---

---

**Paints and varnishes — Electrochemical measurement of the protection provided to steel by paint coatings — Current interrupter (CI) technique, relaxation voltammetry (RV) technique and DC transient (DCT) measurements**

iTeh STANDARD PREVIEW  
(standards.iteh.ai)

*Peintures et vernis — Mesurage électrochimique de la protection apportée à l'acier par des revêtements de peinture — Technique du courant interrompu (CI), voltamétrie de relaxation (VR) et mesurages de courants continus transitoires (CCT)*

ISO 13129:2012

<https://standards.iteh.ai/catalog/standards/sist/766aa784-fd94-42cd-9fea-a4f50e27a924/iso-13129-2012>



## iTeh STANDARD PREVIEW (standards.iteh.ai)

ISO 13129:2012

<https://standards.iteh.ai/catalog/standards/sist/766aa784-fd94-42cd-9fea-a4f50e27a924/iso-13129-2012>



### **COPYRIGHT PROTECTED DOCUMENT**

© ISO 2012

All rights reserved. Unless otherwise specified, no part of this publication may be reproduced or utilized in any form or by any means, electronic or mechanical, including photocopying and microfilm, without permission in writing from either ISO at the address below or ISO's member body in the country of the requester.

ISO copyright office  
Case postale 56 • CH-1211 Geneva 20  
Tel. + 41 22 749 01 11  
Fax + 41 22 749 09 47  
E-mail [copyright@iso.org](mailto:copyright@iso.org)  
Web [www.iso.org](http://www.iso.org)

Published in Switzerland

<b>Contents</b>	<b>Page</b>
Foreword .....	iv
Introduction .....	v
<b>1 Scope</b> .....	<b>1</b>
<b>2 Normative references</b> .....	<b>1</b>
<b>3 Terms and definitions</b> .....	<b>1</b>
<b>4 Apparatus</b> .....	<b>2</b>
4.1 Faraday cage .....	2
4.2 Cell for sample, including electrode holder .....	2
4.3 Galvanostat .....	3
4.4 Potentiostat .....	3
4.5 Electrodes .....	3
4.6 Electrolyte .....	4
<b>5 Specimens</b> .....	<b>4</b>
5.1 Preconditioning of specimens .....	4
5.2 Environmental control .....	4
5.3 Evaluation of specimens exposed to weathering in the laboratory and in the field .....	4
5.4 Number of specimens and repeatability of results .....	5
<b>6 Experimental procedure</b> .....	<b>5</b>
6.1 General .....	5
6.2 Current interrupter technique .....	5
6.3 Relaxation voltammetry .....	6
6.4 DC transient measurements .....	7
<b>7 Expression of results</b> .....	<b>8</b>
8 <b>Precision</b> .....	<b>8</b>
9 <b>Test report</b> .....	<b>8</b>
<b>Annex A (normative) Description of the dummy cell</b> .....	<b>10</b>
<b>Annex B (informative) Further considerations concerning measurements on coatings</b> .....	<b>12</b>
<b>Annex C (informative) Examples of results</b> .....	<b>14</b>
<b>Bibliography</b> .....	<b>15</b>

## Foreword

ISO (the International Organization for Standardization) is a worldwide federation of national standards bodies (ISO member bodies). The work of preparing International Standards is normally carried out through ISO technical committees. Each member body interested in a subject for which a technical committee has been established has the right to be represented on that committee. International organizations, governmental and non-governmental, in liaison with ISO, also take part in the work. ISO collaborates closely with the International Electrotechnical Commission (IEC) on all matters of electrotechnical standardization.

International Standards are drafted in accordance with the rules given in the ISO/IEC Directives, Part 2.

The main task of technical committees is to prepare International Standards. Draft International Standards adopted by the technical committees are circulated to the member bodies for voting. Publication as an International Standard requires approval by at least 75 % of the member bodies casting a vote.

Attention is drawn to the possibility that some of the elements of this document may be the subject of patent rights. ISO shall not be held responsible for identifying any or all such patent rights.

ISO 13129 was prepared by Technical Committee ISO/TC 35, *Paints and varnishes*, Subcommittee SC 9, *General test methods for paints and varnishes*.

## iTeh STANDARD PREVIEW (standards.iteh.ai)

ISO 13129:2012

<https://standards.iteh.ai/catalog/standards/sist/766aa784-fd94-42cd-9fea-a4f50e27a924/iso-13129-2012>

## Introduction

Quantitative assessment of protection performance of organic coatings has been required in industry, for example for evaluating the durability of organic coatings or judging the life of protective coatings. Electrochemical methods can be used for these purposes. The current interrupter (CI) technique, relaxation voltammetry (RV) and DC transient (DCT) measurements are simple techniques giving effective data which are comparable with electrochemical impedance spectroscopy (EIS) in principle.

An advantage is that the principle is simple and time for one measurement is short.

## iTeh STANDARD PREVIEW (standards.iteh.ai)

[ISO 13129:2012](https://standards.iteh.ai/catalog/standards/sist/766aa784-fd94-42cd-9fea-a4f50e27a924/iso-13129-2012)

<https://standards.iteh.ai/catalog/standards/sist/766aa784-fd94-42cd-9fea-a4f50e27a924/iso-13129-2012>

**iTeh STANDARD PREVIEW**  
**(standards.iteh.ai)**

ISO 13129:2012

<https://standards.iteh.ai/catalog/standards/sist/766aa784-fd94-42cd-9fea-a4f50e27a924/iso-13129-2012>

# Paints and varnishes — Electrochemical measurement of the protection provided to steel by paint coatings — Current interrupter (CI) technique, relaxation voltammetry (RV) technique and DC transient (DCT) measurements

## 1 Scope

This International Standard specifies the procedure for evaluation of the experimental set-up of electrochemical measurements on high-impedance coated samples using methods that are based on the current interrupter (CI) technique, relaxation voltammetry (RV) or DC transient (DCT) measurements.

It provides specific definitions and guidance on optimizing the collection of CI, RV and DCT data from high-impedance systems. High impedance in the context of intact coatings refers to systems with an impedance greater than  $10^9 \Omega/\text{cm}^2$ . This does not preclude measurements on systems with lower impedance. This International Standard deals in particular with:

- instrumental set-up: requirements and shortcomings;
- data validation: checking the measurement range and the accuracy of the data;
- performing CI, RV, DCT measurements: specimen considerations and instrumental parameters;
- the experimental results: different methods of presenting CI, RV and DCT data.

Following the recommendations should ensure the acquisition of CI, RV and DCT data that can be used to study the performance of the specimen. This International Standard does not give guidelines for the interpretation of the data.

## 2 Normative references

The following referenced documents are indispensable for the application of this document. For dated references, only the edition cited applies. For undated references, the latest edition of the referenced document (including any amendments) applies.

ISO 16773-1, *Paints and varnishes — Electrochemical impedance spectroscopy (EIS) on high-impedance coated specimens — Part 1: Terms and definitions*

## 3 Terms and definitions

For the purposes of this document, the terms and definitions given in ISO 16773-1 and the following apply.

### 3.1

#### excitation

application of a voltage,  $U_{\text{exc}}$ , or current,  $I_{\text{exc}}$ , to force the system into a new state

### 3.2

#### current interrupter method

##### CI method

electrochemical technique which allows the relaxation potential of an electrochemical system to be recorded as a function of time just after the excitation current is interrupted and the potential decay curve obtained to be analysed

**3.3 relaxation voltammetry**  
**RV**  
electrochemical technique in which a potential is applied for a given excitation time and then the current is interrupted and just the potential is monitored as a function of time

**3.4 DC transient measurement**  
**DCT measurement**  
electrochemical technique in which a coated sample is charged such that the potential is shifted and then the sample is isolated and the potential is monitored against time while the potential returns to the open-circuit potential

**3.5 potential/time decay curve**  
curve of potential,  $U(t)$ , plotted over time, while potential is changing after a defined excitation is removed

**3.6 sampling rate**  
number of data points per time interval

**3.7 time constant**  
product of resistor and capacitor values used in equivalent circuits, which has the dimensions of time

## 4 Apparatus

iTeh STANDARD PREVIEW  
(standards.iteh.ai)

**4.1 Faraday cage**  
The Faraday cage shall be constructed of metal sheet which reduces electromagnetic interference to the electrochemical cell (or circuit) and shall be connected to the instrument earth.

### 4.2 Cell for sample, including electrode holder

NOTE 1 Various types of measurement cell exist which are suitable for use with this International Standard. Most commonly used are two-electrode and three-electrode arrangements for measurements in an aqueous electrolyte.

The cell should be constructed of materials that will not corrode, otherwise deteriorate or contaminate the solution (e.g. PMMA, PTFE or glass). A material compatibility test should be carried out.

The cell shall be leak-proof to ensure that the geometrical surface of the specimen does not change with time.

The cell should preferably be designed to allow the following items to be inserted into the electrolyte chamber: the working electrode, the reference electrode, the counter-electrode.

Sometimes a thermometer (for temperature control) and gas inlet/outlet tubes to modify the oxygen content of the electrolyte are used. When using an inert gas, a gas scrubber should be used.

An example of an electrochemical cell is shown in Figure 1.

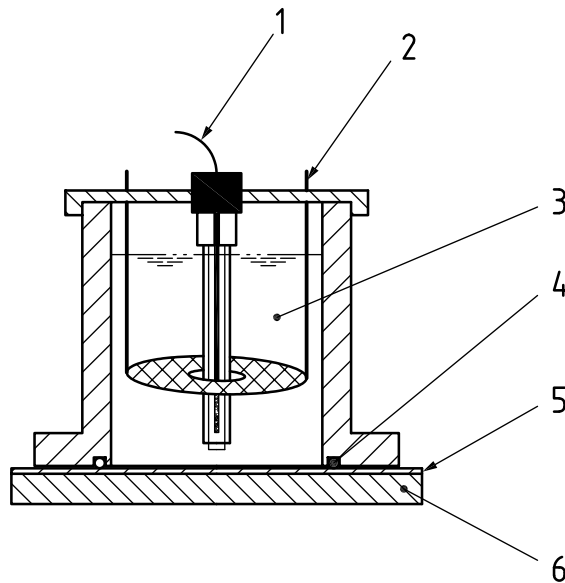

**Key**

- 1 reference electrode
- 2 counter-electrode
- 3 electrolyte
- 4 O-ring
- 5 coating
- 6 working electrode

## iTeh STANDARD PREVIEW (standards.iteh.ai)

**Figure 1 — Example of an electrochemical cell**

<https://standards.iteh.ai/catalog/standards/sist/766aa784-fd94-42cd-9fea-16773-2>

The components shown in Figure 1 are described in ISO 16773-2.

NOTE 2 This drawing does not imply that other designs are unsuitable.

### 4.3 Galvanostat

Use a galvanostat which applies a current with a rectangular pulse waveform and has a fall time no less than 10 times faster than that of the time constant of the sample.

### 4.4 Potentiostat

The potentiostat controls the potential of the working electrode with respect to the reference electrode. The potentiostat input impedance shall be high and the response time shall be fast.

### 4.5 Electrodes

#### 4.5.1 Working electrode

Use as the working electrode a conductive substrate covered by the coating to be investigated. The exposed area should be accurately known, constant with time, and adequate for the investigation. A large area makes the measurement more sensitive for single defects (pores) and gives better signal-to-noise ratio.

#### 4.5.2 Reference electrode

A low-impedance and low-noise reference electrode is recommended (a Luggin probe is not required). The potential of the reference electrode should be checked periodically to verify the accuracy of the electrode and its stability with time.

### 4.5.3 Counter-electrode

Use an inert conductor such as platinum with preferably a large surface area oriented parallel to the working electrode in order to ensure a homogeneous current distribution.

### 4.6 Electrolyte

The resistance of the solution should be low in comparison to the impedance of the system being investigated. Different types of electrolyte may be used. Non-aggressive electrolytes can be employed to characterize the properties of the system without introducing corrosion. An aggressive solution may be selected to characterize the corrosion resistance of the system. The electrolyte should be chosen with the end use of the coating in mind.

## 5 Specimens

### 5.1 Preconditioning of specimens

Proper preparation and preconditioning of coated specimens is critical for successful and reliable experimental data.

### 5.2 Environmental control

The coating should be applied and cured in accordance with the manufacturer's recommendations unless otherwise agreed upon between the interested parties. The film thickness should be as uniform as possible. The exact film thickness should be measured and reported (e.g. in accordance with ISO 2808). Temperature and humidity control during the application, curing, conditioning and measurement of organic coatings is crucial for a proper determination of the coating resistance.

The temperature of the specimens during measurements should be held constant to within  $\pm 2$  °C, preferably within  $\pm 1$  °C, at 23 °C, if not otherwise specified. Relative values for comparison between specimens outside these guidelines are acceptable if all the specimens are run under the same conditions. When the coating capacitance is the main parameter of interest, control of relative humidity during specimen conditioning is very important. To ensure reproducible conditioning, the humidity should be  $(50 \pm 5)$  %, unless agreed otherwise.

For reliable measurements, temperature control should be equal to or better than  $\pm 1$  °C. For conditioning prior to measurement, an accuracy of  $\pm 2$  °C is sufficient for most cases. Each specimen should be kept under controlled conditions in order to prevent post-curing, degradation or any unintended irreversible modification of the coating.

### 5.3 Evaluation of specimens exposed to weathering in the laboratory and in the field

Measurements may be used to further characterize coating degradation during a weathering test. Specimens are measured after different elapsed times during the test and on completion of the test. Such weathering tests can be salt spray exposure in accordance with ISO 9227, exposure in a humidity chamber in accordance with ISO 6270-1, or cyclic tests. Other test methods are also used.

It might be advisable to use separate specimens at different elapsed times because a discontinuity in weathering could influence the results. When the coated specimens are removed from the test chamber for measurement, they typically go through a change in temperature and humidity. Some drying-out can occur if they are removed for more than a few minutes. Further, the coating is exposed to an electrolyte in the electrochemical cell, which can be different from the fluid in the test chamber. Therefore, special attention should be given to the precise procedure and timing when changing, removing and replacing specimens for measurement. The procedural details should be reported with the results.

If the measurement is done in an aggressive electrolyte (e.g. one containing an organic solvent), the exposure of the coating to the electrolyte may be considered as an additional component of the weathering test. In the case of cyclic weathering tests, measurements will depend upon the specific cycle the specimens are in. To allow comparison of measurements to reveal trends and changes, sequential measurements should be taken at the same time and in the same part of the cycle.

Stray currents can occur during measurements on a wet surface, even when the measured area is some distance from a scribe or other artificial defect. These stray currents can simulate a damaged coating, even if the coating is in excellent condition. Therefore, it is recommended that preventive measures, such as drying the non-measured area as completely as possible, be taken to avoid stray currents or other potential sources of error.

#### 5.4 Number of specimens and repeatability of results

Coatings are materials with certain inherent properties: holidays, inhomogeneous film thickness, and non-uniform distribution of pigments, fillers and other constituents. It is therefore necessary to test more than one specimen. In most cases, a minimum of three replicate specimens is necessary for reliable results. It should be checked if the uniformity between the different specimen plates is sufficient. It is quite common to find repeatability better than 10 % between the capacitances of replicate specimens, but this depends on the type of coating and the conditions of measurement. More replicates might be necessary to overcome uniformity problems.

Such checks should be the responsibility of the operator and should also be agreed between the interested parties.

Specimens undergoing a rapid change, caused by weathering or other effects producing degradation, can show a larger fluctuation and therefore a lower repeatability.

Most measurement cells contain an electrolyte that is the medium between the coating and the counter-electrode. This means that the dominant process in the first 24 h is the absorption of electrolyte by the coating. To follow this process, the coating should be measured more frequently at the beginning. The exact interval between measurements will depend on the system.

The accuracy, reliability and repeatability of the experimental set-up should be determined on the dummy cells (see Annex A).

**iTeh STANDARD PREVIEW**  
(standards.iteh.ai)

## 6 Experimental procedure

### 6.1 General

[ISO 13129:2012  
https://standards.iteh.ai/catalog/standards/sist/766aa784-fd94-42cd-9fea-a4f50e27a924/iso-13129-2012](https://standards.iteh.ai/catalog/standards/sist/766aa784-fd94-42cd-9fea-a4f50e27a924/iso-13129-2012)

There are three choices for performing the measurement. The three methods are described in 6.2 to 6.4.

Before starting the test with real specimens, the experimental set-up shall be checked with five standard dummy cells (see Annex A).

In all cases and for all methods, electromagnetic interference or electrostatic charging will occur to some extent. It is highly recommended that the specimens be allowed to discharge completely after the Faraday cage has been closed. This requires a certain waiting time before the measurement can be started. In extreme cases, this waiting time can be 1 h or even more.

NOTE Further explanations can be found in Annex B.

### 6.2 Current interrupter technique

#### 6.2.1 Measurement principle

A constant anodic current is applied for a certain period of time until an approximately constant voltage is reached, and then the current is switched off. After switching off, the decay of the potential is recorded. This potential/time curve is analysed using equivalent circuits.

#### 6.2.2 Test of system operation with standard dummy cells

Start with dummy cell 1.

For details of the dummy cells, see Annex A. Connect the working electrode lead to one connection point on the dummy cell and the counter- and reference-electrode leads to the other. Place the dummy cell in a Faraday cage, ensuring that there is no electrical contact between the dummy cell and the conductive surfaces of the Faraday cage.