Laboratory glassware — Petri dishes

Verrerie de laboratoire — Boîtes de Petri

iTeh STANDARD PREVIEW
(standards.iteh.ai)

ISO 13132:2011

<https://standards.iteh.ai/catalog/standards/sist/474927d6-aa89-4a61-b466-04e2eb306439/iso-13132-2011>



iTeh STANDARD PREVIEW
(standards.iteh.ai)

ISO 13132:2011

<https://standards.iteh.ai/catalog/standards/sist/474927d6-aa89-4a61-b466-04e2eb306439/iso-13132-2011>



COPYRIGHT PROTECTED DOCUMENT

© ISO 2011

All rights reserved. Unless otherwise specified, no part of this publication may be reproduced or utilized in any form or by any means, electronic or mechanical, including photocopying and microfilm, without permission in writing from either ISO at the address below or ISO's member body in the country of the requester.

ISO copyright office
Case postale 56 • CH-1211 Geneva 20
Tel. + 41 22 749 01 11
Fax + 41 22 749 09 47
E-mail copyright@iso.org
Web www.iso.org

Published in Switzerland

Foreword

ISO (the International Organization for Standardization) is a worldwide federation of national standards bodies (ISO member bodies). The work of preparing International Standards is normally carried out through ISO technical committees. Each member body interested in a subject for which a technical committee has been established has the right to be represented on that committee. International organizations, governmental and non-governmental, in liaison with ISO, also take part in the work. ISO collaborates closely with the International Electrotechnical Commission (IEC) on all matters of electrotechnical standardization.

International Standards are drafted in accordance with the rules given in the ISO/IEC Directives, Part 2.

The main task of technical committees is to prepare International Standards. Draft International Standards adopted by the technical committees are circulated to the member bodies for voting. Publication as an International Standard requires approval by at least 75 % of the member bodies casting a vote.

Attention is drawn to the possibility that some of the elements of this document may be the subject of patent rights. ISO shall not be held responsible for identifying any or all such patent rights.

ISO 13132 was prepared by Technical Committee ISO/TC 48, *Laboratory equipment*, Subcommittee SC 6, *Glass and plastics ware including volumetric instruments*.

iTeh STANDARD PREVIEW (standards.iteh.ai)

ISO 13132:2011

<https://standards.iteh.ai/catalog/standards/sist/474927d6-aa89-4a61-b466-04e2eb306439/iso-13132-2011>

iTeh STANDARD PREVIEW
(standards.iteh.ai)

ISO 13132:2011

<https://standards.iteh.ai/catalog/standards/sist/474927d6-aa89-4a61-b466-04e2eb306439/iso-13132-2011>

Laboratory glassware — Petri dishes

1 Scope

This International Standard specifies requirements and tests for glass Petri dishes intended for general laboratory purposes and microbiological work.

2 Normative references

The following referenced documents are indispensable for the application of this document. For dated references, only the edition cited applies. For undated references, the latest edition of the referenced document (including any amendments) applies.

ISO 719, *Glass — Hydrolytic resistance of glass grains at 98 °C — Method of test and classification*

3 Types

iTeh STANDARD PREVIEW
(standards.iteh.ai)

Two types of Petri dishes are specified in this International Standard.

- Type 1 – Thick-walled Petri dishes [ISO 13132:2011](https://standards.iteh.ai/catalog/standards/sist/474927d6-aa89-4a61-b466-04e2eb306439/iso-13132-2011)
- Type 2 – Thin-walled Petri dishes <https://standards.iteh.ai/catalog/standards/sist/474927d6-aa89-4a61-b466-04e2eb306439/iso-13132-2011>

4 Nominal sizes and series

4.1 Nominal sizes

Petri dishes shall have the following nominal sizes.

50, 60, 80, 100, 120, 150 and 200 millimetres

NOTE For Series B, nominal sizes refer to the external diameter of the bottom dish.

4.2 Series

Petri dishes shall comply with the following dimensional requirements.

Series A – Dimensions in accordance with Table 1

Series B – Dimensions in accordance with Table 2

5 Designation

Petri dishes in accordance with this International Standard shall be designated by their nominal size followed by the type and the series.

Designation of a thick-walled Petri dish with nominal size of 120 mm, Type 1, Series A:

Petri dish ISO 13132 – 120 × 20 – 1A

If bottom dishes (2) and top dishes (1) are ordered separately, the following designations shall be used.

Designation of a thick-walled bottom dish (2) of nominal size 120 mm, Type 1, Series A:

Petri bottom dish ISO 13132 – 120 × 20 – 1A – 2

Designation of a thick-walled top dish (1) of nominal size 120 mm, Type 1, Series A:

Petri top dish ISO 13132 – 120 × 20 – 1A – 1

6 Material

Petri dishes shall be manufactured from transparent glass of hydrolytic resistance Class HBG 1, Class HBG 2 or Class HGB 3 in accordance with ISO 719. The glass shall be reasonably free from residual strain and from defects which might impair safety, durability or appearance such as mould marks and waviness.

The glass shall not have any pronounced tint.

7 Dimensions

iTeh STANDARD PREVIEW
(standards.iteh.ai)

7.1 Series A Petri dishes

Series A Petri dishes shall comply with the dimensions specified in Table 1.

<https://standards.iteh.ai/catalog/standards/sist/474927d6-aa89-4a61-b466-04e2eb306439/iso-13132-2011>

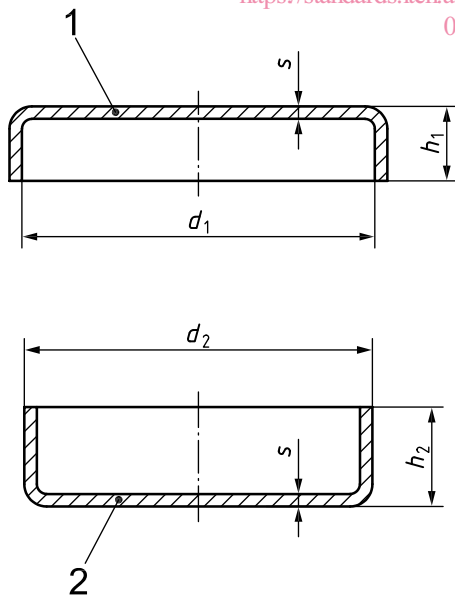

Key

- 1 top dish
- 2 bottom dish

Figure 1 — Thick-walled Petri dish

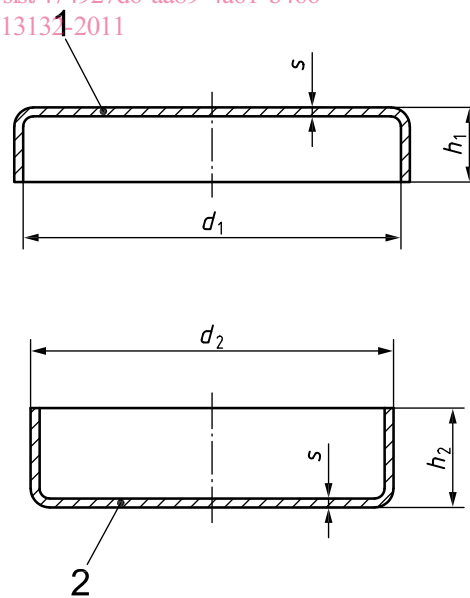

Key

- 1 top dish
- 2 bottom dish

Figure 2 — Thin-walled Petri dish

Table 1 — Dimensions for Series A Petri dishes

Dimensions in millimetres

Nominal size	Type 1 – Thick-walled (see Figure 1)					Type 2 – Thin-walled (see Figure 2)				
	d_1	d_2 0 -1	h_1 ± 1	h_2 ± 1	s \approx	d_1 ± 1	d_2 ± 1	h_1 $\pm 1,5$	h_2 $\pm 1,5$	s $\pm 0,3$
50 × 12	—	—	—	—	—	47	45	9	14	1,3
60 × 20	$55^{+1,5}_0$	54	15	20	2,5	56	53	15	20	1,8
80 × 15	—	—	—	—	—	77	74	11	15	1,3
80 × 20	$71^{+1,5}_0$	70	15	20	2,5	76	73	15	20	1,8
100 × 15	$91^{+1,5}_0$	90	13	15	3	96	93	11,5	15	1,8
100 × 20				20					20	
120 × 20	$111^{+1,5}_0$	110	15	20	3,5	116	113	15	20	1,8
150 × 30	140^{+2}_0	139	15	30	4	146	142	18	27	1,8
200 × 30	—	—	—	—	—	197	193	23	29	1,6

iTech STANDARD PREVIEW

7.2 Series B Petri dishes

(standards.itech.ai)

Series B Petri dishes shall comply with the dimensions specified in Table 2. For any pair of Series B Petri dishes, the difference between the internal diameter of the top dish and external diameter of the bottom dish shall be between 2 mm to 4 mm.

<https://standards.itech.ai/catalog/standards/sist/474927d6-aa89-4a61-b466-04e2eb306439/iso-13132-2011>

Table 2 — Dimensions for Series B Petri dishes

Dimensions in millimetres

Nominal size	Type 2 – Thin-walled (see Figure 2)				
	d_1 $+1$ 0	d_2 0 -1	h_1 0 -1	h_2 $+1$ 0	s min.
50 × 17	53	50	15	17	1,0
80 × 17	83	80	15	17	1,0
100 × 17	103	100	15	17	1,5
150 × 20	153	150	17	20	1,5
200 × 20	203	200	20	20	1,5

8 Construction

8.1 Basic requirements

Petri dishes shall be regular in shape (see e.g. Figure 1) and smoothly finished. They shall be symmetrical about the axis which shall be perpendicular to the plane of the base.

8.2 Base and side

The bases of both the bottom and top dishes shall be, as far as possible, in one plane surface and the sides shall be perpendicular to the base with a maximum deviation of 3°. The bases may be given a slight crown to prevent rocking.

8.3 Edge

The edges of the side wall of both bottom and top dishes shall be smoothly ground, fire-polished or clean pressed. The edges shall be in a plane parallel to their bases. If the edges are finished by burn-off process, there shall not be any tear-drop extending above the plane of cut-off in the bottom dish. In the top dish such protrusion up to 1 mm is permissible.

8.4 Flatness of bottom dishes

The inside depth at any two points on the base of the bottom dish shall not vary by more than 1,2 mm when measured in accordance with Annex A.

8.5 Performance requirements

Petri dishes shall not show visible decrease of transparency, opalescence, iridescence, frosting or cracks after testing by the following procedures:

- minimum 15 min wet sterilization at minimum 120 °C;
- minimum 1 h dry sterilization at minimum 160 °C.

ITEH STANDARD PREVIEW
(standards.iteh.ai)

9 Marking

ISO 13132:2011

[https://standards.iteh.ai/catalog/standards/sist/474927d6-aa89-4a61-b466-](https://standards.iteh.ai/catalog/standards/sist/474927d6-aa89-4a61-b466-04e2b2064396/iso-13132-2011)

Petri dishes shall be permanently and legibly marked on its sidewall with the following information:

- a) manufacturer's and/or supplier's name and/or trade mark;
- b) optionally the number of this International Standard, "ISO 13132".

Annex A **(normative)**

Test method for flatness

The following type test procedure applies for measurement of flatness of the inner surface of the Petri bottom dish.

- a) Affix a dial gauge to a stand.
- b) Place both the measuring equipment and the Petri dish under test on the same flat and firm surface.
- c) Lower the dial gauge in such a way that the pointer is pressed against the inner surface of the Petri dish so that some deflection is seen on the pointer.
- d) Then measure with the dial gauge the difference between the deepest and the highest point of the inner surface which should not exceed the value specified in 8.4.

iTeh STANDARD PREVIEW
(standards.iteh.ai)

[ISO 13132:2011](https://standards.iteh.ai/catalog/standards/sist/474927d6-aa89-4a61-b466-04e2eb306439/iso-13132-2011)

<https://standards.iteh.ai/catalog/standards/sist/474927d6-aa89-4a61-b466-04e2eb306439/iso-13132-2011>