

---

# International Standard



# 918

---

INTERNATIONAL ORGANIZATION FOR STANDARDIZATION • МЕЖДУНАРОДНАЯ ОРГАНИЗАЦИЯ ПО СТАНДАРТИЗАЦИИ • ORGANISATION INTERNATIONALE DE NORMALISATION

---

## Volatile organic liquids for industrial use — Determination of distillation characteristics

*Liquides organiques volatils à usage industriel — Détermination des caractéristiques de distillation*

First edition — 1983-12-01

**ITeH STANDARD PREVIEW**  
**(standards.iteh.ai)**

ISO 918:1983

<https://standards.iteh.ai/catalog/standards/sist/afa9d797-9d11-432b-8714-5e2ffdb5bcab/iso-918-1983>

---

UDC 661.71/.727 : 536.423

Ref. No. ISO 918-1983 (E)

**Descriptors** : industrial products, organic materials, volatile matters, liquids, tests, determination, distillation range, test equipment.

## Foreword

ISO (the International Organization for Standardization) is a worldwide federation of national standards bodies (ISO member bodies). The work of developing International Standards is carried out through ISO technical committees. Every member body interested in a subject for which a technical committee has been authorized has the right to be represented on that committee. International organizations, governmental and non-governmental, in liaison with ISO, also take part in the work.

Draft International Standards adopted by the technical committees are circulated to the member bodies for approval before their acceptance as International Standards by the ISO Council.

International Standard ISO 918 was developed by Technical Committee ISO/TC 47, *Chemistry*, and was circulated to the member bodies in October 1982.

It has been approved by the member bodies of the following countries :

|                     |                |                       |
|---------------------|----------------|-----------------------|
| Australia           | Germany, F. R. | Portugal              |
| Austria             | Hungary        | Romania               |
| Belgium             | India          | South Africa, Rep. of |
| China               | Italy          | Switzerland           |
| Czechoslovakia      | New Zealand    | USSR:1983             |
| Egypt, Arab Rep. of | Nigeria        |                       |
| France              | Poland         |                       |

The member body of the following country expressed disapproval of the document on technical grounds :

Netherlands

This International Standard cancels and replaces ISO Recommendation R 918-1969, of which it constitutes a technical revision.

This International Standard is one of three ISO publications dealing with the determination of distillation characteristics. The two others are :

- ISO 3405, *Petroleum products — Determination of distillation characteristics.*
- ISO 4626, *Volatile organic liquids — Determination of boiling range of organic solvents used as raw materials.*

It is recognized that there may be some overlapping between these three documents which were developed in separate technical committees. In the absence of agreement on a general International Standard on the subject, it has however been thought necessary to publish them.

The completion in the future of such a general standard may therefore lead to the amendment or cancellation of this International Standard.

# Volatile organic liquids for industrial use — Determination of distillation characteristics

## 1 Scope and field of application

This International Standard specifies an apparatus and method for the determination of distillation characteristics of volatile organic liquids which (excluding petroleum products) having a boiling point in the range 30 to 300 °C approximately and are stable during distillation in atmospheric conditions.

## 2 References

ISO 3405, *Petroleum products — Determination of distillation characteristics*.

ISO 4626, *Volatile organic liquids — Determination of boiling range of organic solvents used as raw materials*.

## 3 Definitions (see ISO 3405 and ISO 4626)

**3.1 initial boiling point** : The temperature noted (corrected, if required) at the moment when the first drop of condensate falls from the tip of the condenser during a distillation carried out under standardized conditions.

**3.2 final boiling point** : The maximum temperature noted (corrected, if required) during the final phase of the distillation of a sample carried out under standardized conditions.

**3.3 dry point** : The temperature noted (and corrected, if required) at the moment of vaporization of the last drop of liquid at the bottom of a flask, during a distillation carried out under standardized conditions.

**3.4 boiling range** : The temperature interval between the initial boiling point and the dry point.

## 4 Principle

Distillation of a test portion, under carefully defined conditions in order to determine either

**4.1** the temperatures corresponding to the condensate volumes defined in the International Standard for the product under test; these temperatures shall be corrected as indicated in clause 9, unless the nature of the product provides only for a difference of temperature between two volumes of condensate, (plotting temperature as a function of volume); or

**4.2** the volume of condensate when the thermometer indicates each of the distillation temperatures (previously adjusted as indicated in clause 9) specified in the International Standard for the product under test (plotting volume as a function of temperature).

## 5 Apparatus

Ordinary laboratory apparatus, and

**5.1 Distillation apparatus**, as shown in figure 1 comprising

**5.1.1 Distillation flask**, available capacity 100 ml, of borosilicate glass, as shown in figure 2.

**5.1.2 Thermometer**, of the mercury-in-glass type, graduated in 0,2 °C intervals, having a maximum error of  $\pm 0,2$  °C and covering a range suitable for the products being tested.

The distance between the top of the bulb and the first graduation mark is at least 100 mm. The thermometer has no contraction chamber unless this is very close to the bulb or contained therein.

The scale is calibrated for use at 100 mm immersion (or alternatively for total immersion).

Additional requirements, in particular concerning the range of the thermometer, may be given in the International Standards for the products under test.

**5.1.3 Receiver**, 100 ml capacity, graduated as shown in figure 3.

**5.1.4 Condenser** of the Liebig/West type, of borosilicate glass, as shown in figure 4. The inner tube shall have the following dimensions :

|  |                   |
|--|-------------------|
| Internal diameter                              | 14,0 $\pm$ 1,0 mm |
| Wall thickness                                 | 1,0 to 1,5 mm     |
| Length of straight portion of longer limb      | 600 $\pm$ 10 mm   |
| Length of shorter limb                         | 55 $\pm$ 5 mm     |
| Angle included between longer and shorter limb | 97 $\pm$ 3°       |

The inlet of the inner tube of the condenser shall be finished square with its axis and its outlet, smoothly ground at an angle

of approximately 45° to the axis of the tube at that point, as shown in figure 4.

The length of the central straight portion of the water jacket shall be 450 ± 10 mm, and its external diameter 35 ± 3 mm.

**5.1.5 Draught screen**, rectangular in cross-section and open at the top and bottom. It shall have the dimensions shown in figure 5 and shall be made of sheet metal 0,7 mm thick.

In each of the two narrower sides of the draught screen are two air-vent holes 25 mm in diameter situated below the heat-resistant shelf, as shown in figure 5.

In each of the four sides of the draught screen are three air-vent holes with their centre 25 mm above the base of the draught screen. These holes occupy the positions shown in figure 5, the diameter of the holes situated centrally in the wider side being 25 mm, and the diameter of the remaining 10 holes 12,5 mm.

At the middle of each of the wider sides, a vertical slot for the side tube of the distillation flask, dimensioned as shown in figure 5, is cut downwards from the top of the screen. A removable shutter, conforming to the dimensions in figure 5, is provided for closing whichever vertical slot is not in use.

A shelf of hard heat-resistant board 6 mm in thickness and possessing a centrally cut circular hole 110 mm in diameter, is supported horizontally in the screen and fits closely to the sides of the screen, to ensure that hot gases from the source of heat do not come into contact with the sides or neck of the flask. The supports for shelf may consist of triangular pieces of metal sheet firmly fixed to the screen at its four corners.

In one of the narrower sides of the screen, a door is provided having the dimensions shown in figure 5 and overlapping an opening in the screen by approximately 5 mm all round.

In each of the narrower sides of the screen, a mica window is placed centrally with the bottom of the window level with the top of the heat-resistant shelf. The dimensions and the positions of the windows are shown in figure 5.

**5.1.6 Heat-resistant board.**

In addition to the heat-resistant shelf referred to in 5.1.5, a heat-resistant board 150 mm square and 6 mm in thickness is required. It has a central hole of 50 mm diameter, unless otherwise stated in the specification for the material under test.

**5.2 Assembly of the apparatus**

Assemble the distillation apparatus as shown in figure 1.

**5.2.1 Position of thermometer**

The thermometer shall be held in the neck of the flask by means of a well-fitting stopper of a material which is not attacked by

the liquid under test. The junction of the capillary tube and the main bulb of the thermometer shall be maintained level with the lower edge of the joint between the side tube and the neck of the flask. The stopper shall project about 10 mm above the top of the neck of the flask.

When the thermometer is fixed in position as indicated above, the immersion line on the thermometer will be in the neighbourhood of the top of the stopper holding the thermometer in position in the neck of the flask.

**5.2.2 Support for flask**

The heat-resistant board (5.1.6) shall be placed on the top of the heat-resistant shelf of the draught screen so that the two holes are approximately concentric. The flask is then placed in position so as to close the hole in the heat-resistant board completely.

**5.2.3 Connection of flask to condenser**

The flask shall be connected to the condenser so that the end of the side tube projects at least 25 mm into the condenser and is coaxial with it.

**6 Sampling<sup>1)</sup>**

Store the laboratory sample in a clean, dry and air-tight dark-glass flask, fitted either with a ground glass stopper or with a screw cap containing an air-tight inert plastics seal. The bottle should be of such capacity that it is almost entirely filled by the sample. If it is necessary to seal the container, take care to avoid any contamination of the contents.

If special precautions are necessary, they shall be given in the appropriate International Standard test methods.

To carry out the test specified in this International Standard, a laboratory sample of 500 ml is recommended.

**7 Procedure**

**7.1 Test portion**

Using the receiver (5.1.3) take 100 ± 1 ml of the laboratory sample.

If the expected distillation temperature lies below 70 °C, adjust the temperature of the sample, before taking it, to the appropriate value shown in table 1.

**Table 1 — Sampling temperatures**

Values in degrees Celsius

| Initial boiling point | Condenser | Sample   |
|-----------------------|-----------|----------|
| Below 50              | 0 to 3    | 0 to 3   |
| 50 to 70              | 0 to 10   | 10 to 20 |
| 70 to 150             | 25 to 30  | 20 to 30 |
| Above 150             | 35 to 50  | 20 to 30 |

1) The sampling of liquid chemical products for industrial use will form the object of a future International Standard.

## 7.2 Distillation

**WARNING** — Carry out the distillation in a well-ventilated fume cupboard.

Transfer the test portion (7.1) as completely as possible to the distillation flask (5.1.1) and add a few small pieces of clean, dry porous pot. Place the flask and its contents, the thermometer (5.1.2) and the receiver (5.1.3) in position and ensure that the condenser has a steady supply of water.

NOTE — For materials expected to boil below 70 °C, the temperature of the water supply of the condenser and the temperature of the receiver should be adjusted to the values indicated in table 1. In this case, immerse the receiver in a transparent cold water bath maintained at the values of temperatures indicated in table 1.

Light the burner and adjust the flame so that the first drop of distillate falls from the end of the condenser after 5 to 10 min for materials boiling below 100 °C, after 10 to 15 min for materials boiling above 100 °C, or after any other interval, as indicated in the specification, for the material under test.

Again adjust the flame so that the condensate is collected at the rate of 3 to 4 ml/min corresponding to approximately 2 drops per second, unless otherwise stated in the specification of the material under test. This can be achieved by adjusting the distance between the burner and the bottom of the flask so that the flame of minimum size only is necessary.

Record, as appropriate,

- temperature as a function of volume (4.1);
- volume as a function of temperature (4.2).

In addition, record the atmospheric pressure and the temperature of the barometer on taking the reading.

## 8 Corrections to barometer readings

Atmospheric pressure is generally measured by means of a mercury barometer (Fortin type), having a brass scale calibrated in millibars (mbar). A Standard atmosphere (atm) = 1 013,25 mbar = 101 325 Pa (see ISO 31/3).

NOTE — If the barometer is calibrated in millimetres of mercury, multiply the observed value by 1,332 89 (rounded up to 1,333) in order to obtain the corresponding value in millibars.

If, however, the pressure reading is given in pascals (Pa), note the following equivalent values :

1 bar = 1 000 mbar = 10<sup>5</sup> Pa = 100 kPa = 0,1 MPa (see ISO 31/3).

### 8.1 Index correction

Initially correct the observed barometer reading in accordance with the inspection certificate issued with the instrument. The reading thus corrected gives the atmospheric pressure as would be indicated by a correctly adjusted barometer at the temperature and at the latitude of the place of observation.

### 8.2 Temperature correction to 0 °C

Correct the value obtained in 8.1 to 0 °C, taking into account the temperature at which the reading was taken and the type of barometer used.

If the mercury barometer is of the Fortin type, or of any other type in which the mercury is set to a fiducial level when the barometric reading is taken, apply the correction given in table 2.

If the barometer used is of the Kew type, i.e. one in which the barometric reading is taken without adjusting the level of the mercury in the reservoir, the temperature correction will differ somewhat from that given in table 2. The temperature coefficient of a Kew pattern barometer depends to a small extent on its dimensions, but sufficient accuracy will be obtained, in general, if the temperature correction to a reading of a Kew pattern barometer is taken to be 5 % in excess of that given in table 2.

### 8.3 Correction to standard gravity

The barometric pressure, as corrected in accordance with 8.1 and 8.2 is given in standard millibars at 0 °C, at the place of observation. However, if the distillation is carried out in latitudes where the value of gravity differs from the standard value, a third correction is necessary to obtain the equivalent value under standard gravity. Multiply the value obtained as

above by  $\frac{g}{9,806 65}$  where  $g$  is the acceleration of free fall, expressed in metres per second squared, at the place of observation. The correction to standard gravity is carried out by reference to table 3 which gives the appropriate corrections for different latitudes. According to whether the sign of the correction in table 3 is positive or negative, add or subtract the value shown.

Variations in gravity due to causes other than change in latitude, e.g. height above sea level, may be neglected.

## 9 Temperature corrections

### 9.1 For temperature readings as a function of volume (see 4.1)

These corrections shall be applied after the distillation.

#### 9.1.1 Corrections for thermometer error

If the thermometer gives incorrect readings at the observed initial boiling point or dry point, correct the readings by subtracting the amount of error if the thermometer is reading high, or adding the amount of error if the thermometer is reading low.

Also make corrections for the emergent stem of the thermometer when using a thermometer calibrated for total immersion.

**Table 2 — Correction of barometer readings to 0 °C Fortin barometer with brass scale**  
(Subtract the correction from the barometric reading)

| Temperature of barometer °C | Barometer reading, mbar <sup>1)</sup> |      |      |       |       |       |       |       |
|-----------------------------|---------------------------------------|------|------|-------|-------|-------|-------|-------|
|                             | 925                                   | 950  | 975  | 1 000 | 1 025 | 1 050 | 1 075 | 1 100 |
| 10                          | 1,51                                  | 1,55 | 1,59 | 1,63  | 1,67  | 1,71  | 1,75  | 1,79  |
| 11                          | 1,66                                  | 1,70 | 1,75 | 1,79  | 1,84  | 1,88  | 1,93  | 1,97  |
| 12                          | 1,81                                  | 1,86 | 1,90 | 1,95  | 2,00  | 2,05  | 2,10  | 2,15  |
| 13                          | 1,96                                  | 2,01 | 2,06 | 2,12  | 2,17  | 2,22  | 2,28  | 2,33  |
| 14                          | 2,11                                  | 2,16 | 2,22 | 2,28  | 2,34  | 2,39  | 2,45  | 2,51  |
| 15                          | 2,26                                  | 2,32 | 2,38 | 2,44  | 2,50  | 2,56  | 2,63  | 2,69  |
| 16                          | 2,41                                  | 2,47 | 2,54 | 2,60  | 2,67  | 2,73  | 2,80  | 2,87  |
| 17                          | 2,56                                  | 2,63 | 2,70 | 2,77  | 2,83  | 2,90  | 2,97  | 3,04  |
| 18                          | 2,71                                  | 2,78 | 2,85 | 2,93  | 3,00  | 3,07  | 3,15  | 3,22  |
| 19                          | 2,86                                  | 2,93 | 3,01 | 3,09  | 3,17  | 3,25  | 3,32  | 3,40  |
| 20                          | 3,01                                  | 3,09 | 3,17 | 3,25  | 3,33  | 3,42  | 3,50  | 3,58  |
| 21                          | 3,16                                  | 3,24 | 3,33 | 3,41  | 3,50  | 3,59  | 3,67  | 3,76  |
| 22                          | 3,31                                  | 3,40 | 3,49 | 3,58  | 3,67  | 3,76  | 3,85  | 3,94  |
| 23                          | 3,46                                  | 3,55 | 3,65 | 3,74  | 3,83  | 3,93  | 4,02  | 4,12  |
| 24                          | 3,61                                  | 3,71 | 3,81 | 3,90  | 4,00  | 4,10  | 4,20  | 4,29  |
| 25                          | 3,76                                  | 3,86 | 3,96 | 4,06  | 4,17  | 4,27  | 4,37  | 4,47  |
| 26                          | 3,91                                  | 4,01 | 4,12 | 4,23  | 4,33  | 4,44  | 4,55  | 4,66  |
| 27                          | 4,06                                  | 4,17 | 4,28 | 4,39  | 4,50  | 4,61  | 4,72  | 4,83  |
| 28                          | 4,21                                  | 4,32 | 4,44 | 4,55  | 4,66  | 4,78  | 4,89  | 5,01  |
| 29                          | 4,36                                  | 4,47 | 4,59 | 4,71  | 4,83  | 4,95  | 5,07  | 5,19  |
| 30                          | 4,51                                  | 4,63 | 4,75 | 4,87  | 5,00  | 5,12  | 5,24  | 5,37  |

1) If the barometer is calibrated in millimetres of mercury, see the note to clause 8.

ISO 918:1983

<https://standards.iteh.ai/catalog/standards/sist/afa9d797-9d11-432b-8714-5e2f5db5bcab/iso-918-1983>

**Table 3 — Correction of barometer readings to standard gravity**  
( $g_n = 9,806 65 \text{ m/s}^2$ )

| Latitude degrees | Barometric reading, mbar |       |       |       |       |       |       |       |
|------------------|--------------------------|-------|-------|-------|-------|-------|-------|-------|
|                  | 925                      | 950   | 975   | 1 000 | 1 025 | 1 050 | 1 075 | 1 100 |
| 0                | -2,48                    | -2,55 | -2,62 | -2,69 | -2,76 | -2,83 | -2,90 | -2,97 |
| 5                | -2,44                    | -2,51 | -2,57 | -2,64 | -2,71 | -2,77 | -2,84 | -2,91 |
| 10               | -2,35                    | -2,41 | -2,47 | -2,53 | -2,59 | -2,65 | -2,71 | -2,77 |
| 15               | -2,16                    | -2,22 | -2,28 | -2,34 | -2,39 | -2,45 | -2,51 | -2,57 |
| 20               | -1,92                    | -1,97 | -2,02 | -2,07 | -2,12 | -2,17 | -2,23 | -2,28 |
| 25               | -1,61                    | -1,66 | -1,70 | -1,75 | -1,79 | -1,84 | -1,89 | -1,94 |
| 30               | -1,27                    | -1,30 | -1,33 | -1,37 | -1,40 | -1,44 | -1,48 | -1,52 |
| 35               | -0,89                    | -0,91 | -0,93 | -0,95 | -0,97 | -0,99 | -1,02 | -1,05 |
| 40               | -0,48                    | -0,49 | -0,50 | -0,51 | -0,52 | -0,53 | -0,54 | -0,55 |
| 45               | -0,05                    | 0,05  | -0,05 | -0,05 | -0,05 | -0,05 | -0,05 | -0,05 |
| 50               | +0,37                    | +0,39 | +0,40 | +0,41 | +0,43 | +0,44 | +0,45 | +0,46 |
| 55               | +0,79                    | +0,81 | +0,83 | +0,86 | +0,88 | +0,91 | +0,93 | +1,95 |
| 60               | +1,17                    | +1,20 | +1,24 | +1,27 | +1,30 | +1,33 | +1,36 | +1,39 |
| 65               | +1,52                    | +1,56 | +1,60 | +1,65 | +1,69 | +1,73 | +1,77 | +1,81 |
| 70               | +1,83                    | +1,87 | +1,92 | +1,97 | +2,02 | +2,07 | +2,12 | +2,17 |



### 9.1.2 Correction for barometric pressure

When the barometric pressure, corrected as in clause 8, deviates from 1 013,25 mbar, apply further corrections (see clause 10) to the observed distillation temperatures, as indicated in the specification for the product under test, or in the literature.

## 9.2 For volume readings as a function of temperature (see 4.2)

These corrections shall be applied before commencing distillation.

### 9.2.1 Correction for thermometer error

If the thermometer gives incorrect readings at the specified distillation temperatures, corrected in accordance with 9.2.2, correct the readings by adding the amount of error if the thermometer is reading high, or subtracting the amount of error if the thermometer is reading low.

Also make corrections for the emergent stem of the thermometer when using a thermometer calibrated for total immersion.

### 9.2.2 Correction for barometric pressure

When the barometric pressure, corrected as in clause 8, deviates from 1 013,25 mbar, apply further corrections (see clause 10) to the observed distillation temperatures, as indicated in the specification for the product under test, or in the literature.

## 10 Expression of results

Apply the corrections specified in clauses 8 and 9 to the barometric pressure and temperature readings, respectively.

In order to calculate the correction which is to be applied to the coefficient of variation of the boiling point of a given product as a function of pressure (see 9.1.2 and 9.2.2) apply the following formula, adding algebraically the result obtained to the temperatures :

$$CV (1\,013,25 - p) \text{ } ^\circ\text{C}$$

where

CV is the rate of change of boiling point with pressure, in degrees Celsius per millibar,<sup>1)</sup> of the material under test;

p is the atmospheric pressure, in millibars, taken during the test, corrected in accordance with clause 8;

1 013,25 is standard atmospheric pressure, in millibars.

NOTE — If the overall distillation range of the test portion does not exceed 2 °C, combined corrections for thermometer error and barometric pressure may be made on the basis of the difference between the observed 50 % boiling point and the true boiling point at 1 013,25 mbar (see ISO 4626, table 3).

Report the characteristics required for the product under consideration.

## 11 Test report

The test report shall include the following particulars :

- a) an identification of the sample;
- b) the reference of the method used;
- c) the results and the method of expression used;
- d) any unusual features noted during the determination;
- e) any operation not included in this International Standard or in the International Standards to which reference is made, or regarded as optional.

1) A list of values regarding the most important organic solvents used in the paints and varnish industry is given in ISO 4626.

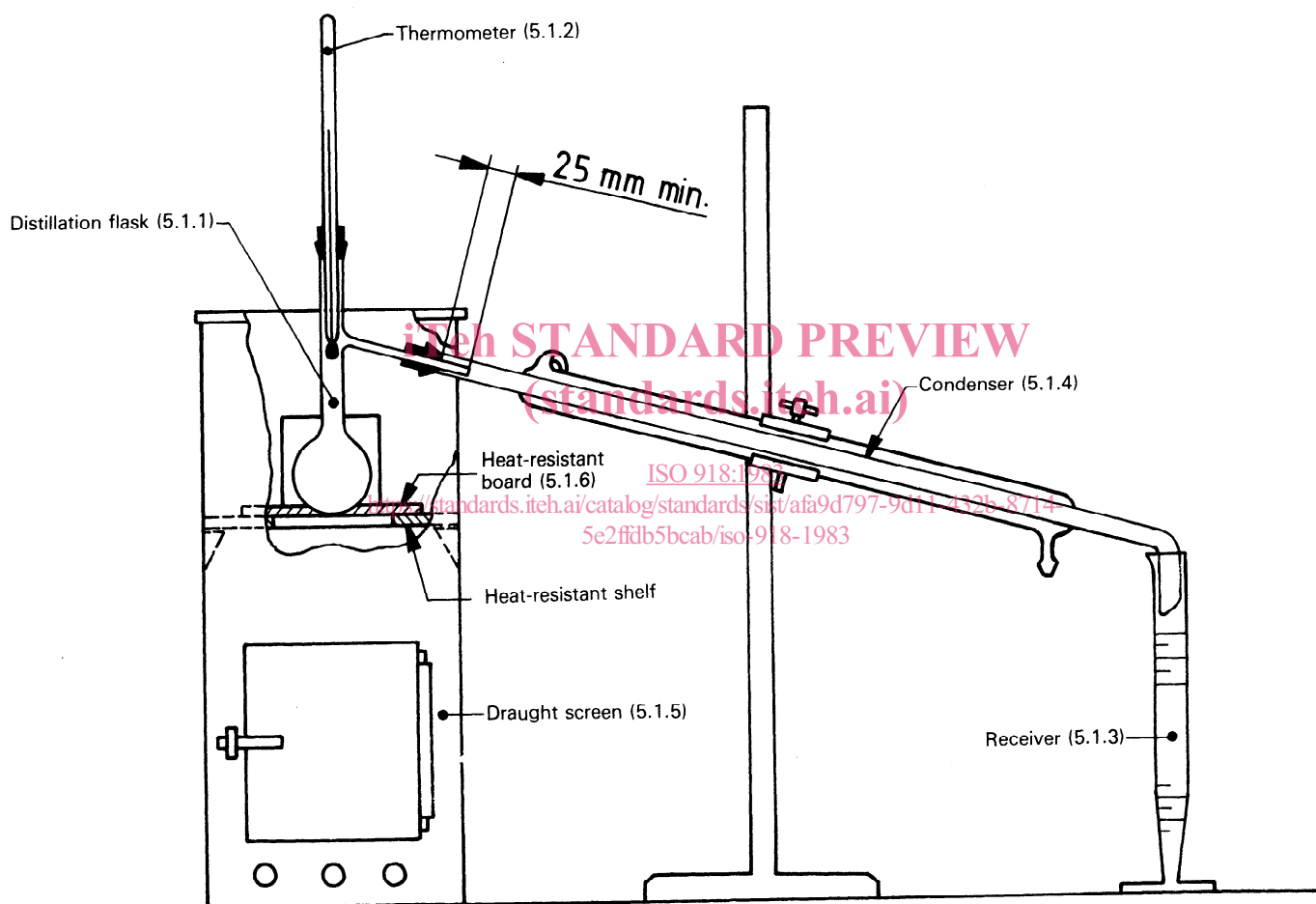

Figure 1 – Assembly of distillation apparatus (5.1)



Linear dimensions in millimetres

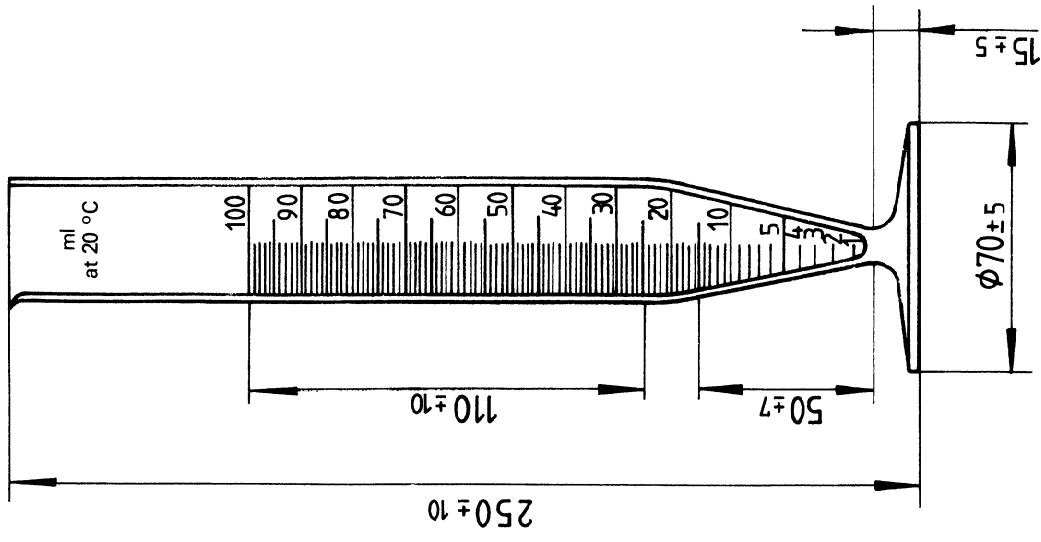

Figure 3 — Distillation receiver (5.1.3)

Linear dimensions in millimetres

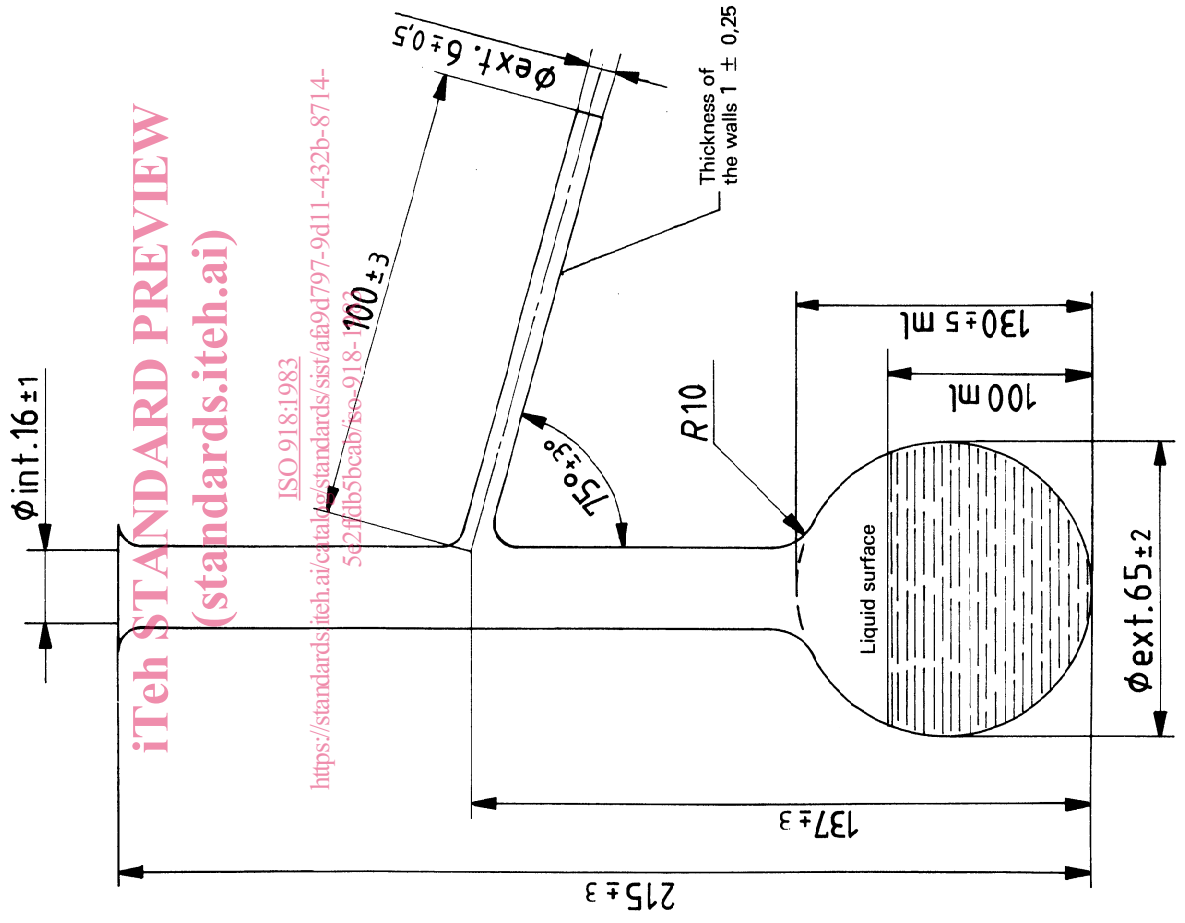

Figure 2 — Distillation flask (5.1.1)