**Assembly tools for screws and nuts —
Driving squares —**

Part 1:
Driving squares for hand socket tools

Outils de manœuvre pour vis et écrous — Carrés d'entraînement —

Partie 1: Carrés d'entraînement pour outils à main

iTeh STANDARD PREVIEW
(standards.iteh.ai)

ISO 1174-1:2011

<https://standards.iteh.ai/catalog/standards/sist/d0b02e6e-13b9-4e65-8553-c311b9f2a8bd/iso-1174-1-2011>



iTeh STANDARD PREVIEW (standards.iteh.ai)

ISO 1174-1:2011

<https://standards.iteh.ai/catalog/standards/sist/d0b02e6e-13b9-4e65-8553-c311b9f2a8bd/iso-1174-1-2011>



COPYRIGHT PROTECTED DOCUMENT

© ISO 2011

All rights reserved. Unless otherwise specified, no part of this publication may be reproduced or utilized in any form or by any means, electronic or mechanical, including photocopying and microfilm, without permission in writing from either ISO at the address below or ISO's member body in the country of the requester.

ISO copyright office
Case postale 56 • CH-1211 Geneva 20
Tel. + 41 22 749 01 11
Fax + 41 22 749 09 47
E-mail copyright@iso.org
Web www.iso.org

Published in Switzerland

Foreword

ISO (the International Organization for Standardization) is a worldwide federation of national standards bodies (ISO member bodies). The work of preparing International Standards is normally carried out through ISO technical committees. Each member body interested in a subject for which a technical committee has been established has the right to be represented on that committee. International organizations, governmental and non-governmental, in liaison with ISO, also take part in the work. ISO collaborates closely with the International Electrotechnical Commission (IEC) on all matters of electrotechnical standardization.

International Standards are drafted in accordance with the rules given in the ISO/IEC Directives, Part 2.

The main task of technical committees is to prepare International Standards. Draft International Standards adopted by the technical committees are circulated to the member bodies for voting. Publication as an International Standard requires approval by at least 75 % of the member bodies casting a vote.

ISO 1174-1 was prepared by Technical Committee ISO/TC 29, *Small tools*, Subcommittee SC 10, *Assembly tools for screws and nuts, pliers and nippers*.

This second edition cancels and replaces the first edition (ISO 1174-1:1996), Table 1 and Figure 2 of which have been technically revised.

ISO 1174 consists of the following parts, under the general title *Assembly tools for screws and nuts — Driving squares*:

— *Part 1: Driving squares for hand socket tools*

[ISO 1174-1:2011](https://standards.iteh.ai/catalog/standards/sist/d0b02e6e-13b9-4e65-8553-c311b912a8bd/iso-1174-1-2011)

— *Part 2: Driving squares for power socket tools*

<https://standards.iteh.ai/catalog/standards/sist/d0b02e6e-13b9-4e65-8553-c311b912a8bd/iso-1174-1-2011>

iTeh STANDARD PREVIEW
(standards.iteh.ai)

ISO 1174-1:2011

<https://standards.iteh.ai/catalog/standards/sist/d0b02e6e-13b9-4e65-8553-c311b9f2a8bd/iso-1174-1-2011>

Assembly tools for screws and nuts — Driving squares —

Part 1: Driving squares for hand socket tools

1 Scope

This part of ISO 1174 specifies the dimensions, separation force and designation of driving squares for hand socket tools.

NOTE Driving squares for power socket tools are dealt with in ISO 1174-2.

2 Normative references

The following referenced documents are indispensable for the application of this document. For dated references, only the edition cited applies. For undated references, the latest edition of the referenced document (including any amendments) applies.

ISO 3, *Preferred numbers — Series of preferred numbers*

ISO 286-1, *Geometrical product specifications (GPS) — ISO code system for tolerances on linear sizes — Part 1: Bases of tolerances, deviations and fits*

3 Dimensions

3.1 General

Nominal dimensions of driving squares, in millimetres, have been selected from the values of the R 10 series of preferred numbers in accordance with ISO 3.

3.2 Interchangeability

Driving square maximum and minimum dimensions have been selected for the types of tool described in 3.3 and 3.4 so as to allow for interchangeability, whatever the measurement system used.

Deviations, between maximum and minimum dimensions correspond

- for s_1 , to tolerances of grade IT11 in accordance with ISO 286-1, and
- for s_2 , to tolerances of grade IT13 in accordance with ISO 286-1.

When using male square drives with a plunger retainer instead of a ball, only female squares with retaining holes as opposed to recesses should be used.

3.3 Male squares

See Figures 1 and 2 and Table 1.

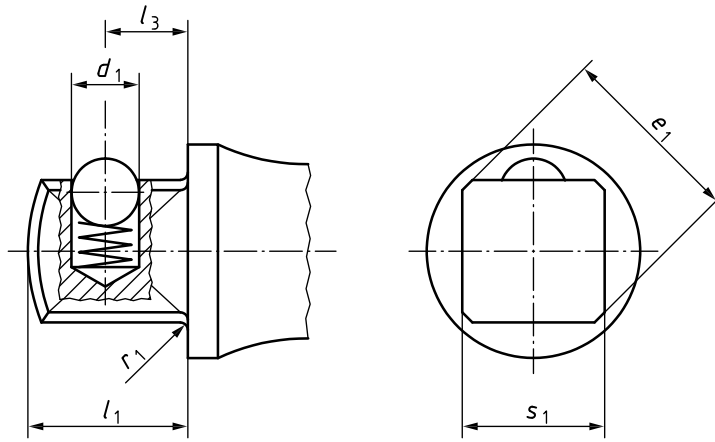

Figure 1 — Type A with ball

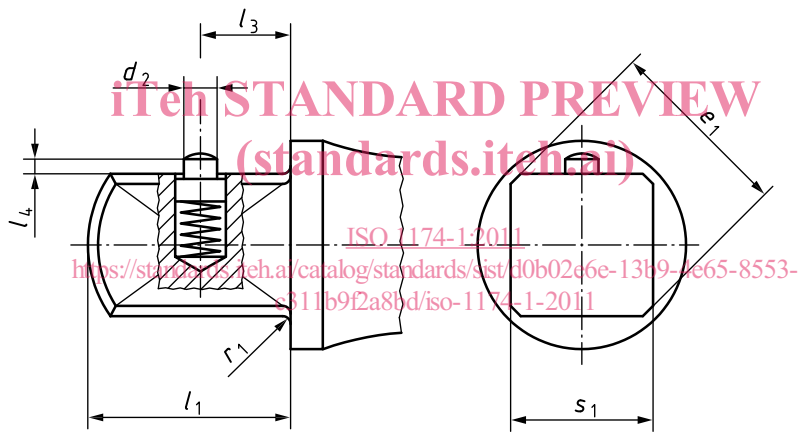

Figure 2 — Type B with plunger retainer

Table 1 — Male square dimensions — Types A and B

Dimensions in millimetres

Type ^a	s ₁			d ₁	d ₂	e ₁		l ₁	l ₃		l ₄	r ₁
	nom.	max.	min.	≈	max.	max.	min.	max.	nom.	tol.	min. ^b	max.
A (B)	6,3	6,35	6,26	3	2	8,4	8,0	7,5	4	±0,2	0,9	0,5
A (B)	10	9,53	9,44	5	2,6	12,7	12,2	11	5,5	±0,2	0,9	0,6
A (B)	12,5	12,70	12,59	6	3	16,9	16,3	15,5	8	±0,3	1,0	0,8
B (A)	20	19,05	18,92	7	4,3	25,4	24,4	23	10,2	±0,3	1,0	1,2
B	25	25,40	25,27	—	5	34,0	32,4	28	15	±0,3	1,0	1,6

NOTE It is not recommended that types B and C be used together.

^a Types given in brackets are non-preferred.

^b Rounded values given, based on the calculation $l_{4,min} = s_{2,max} - s_{1,min} + 0,5$ mm.

3.4 Female squares

See Figures 3 and 4 and Table 2.

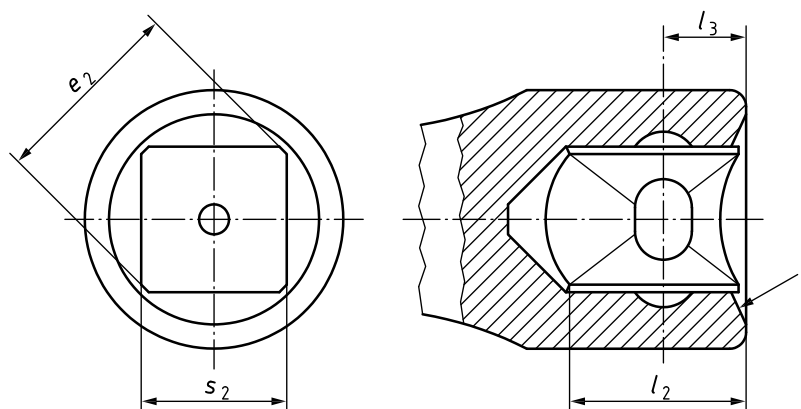

^a Chamfered or rounded in conformity with radius, r_1 , of the male square.

Figure 3 — Type C

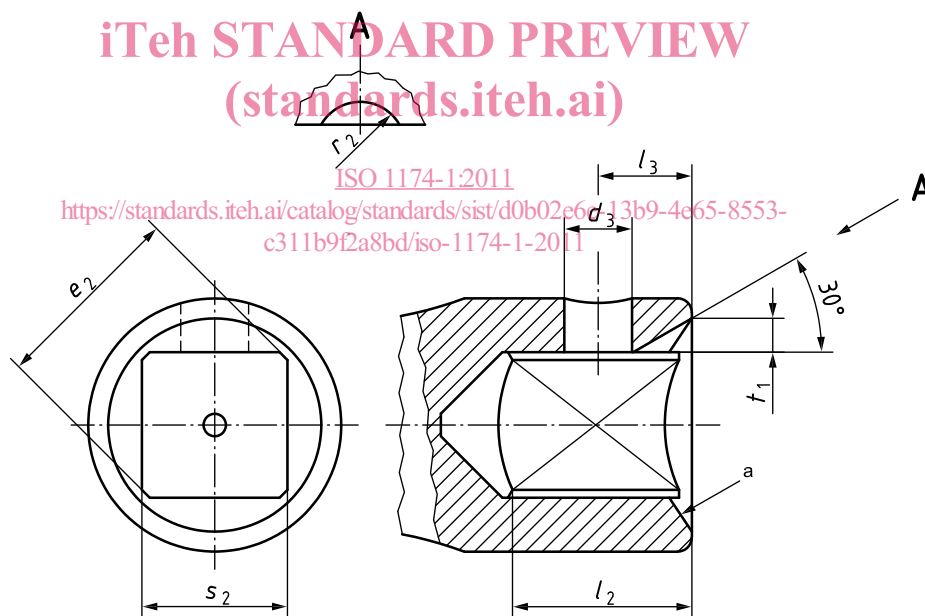

^a Chamfered or rounded in conformity with radius, r_1 , of the male square.

Figure 4 — Type D

Table 2 — Female square dimensions — Types C and D

Dimensions in millimetres

Type ^a	s ₂			d ₃	e ₂	l ₂	l ₃		r ₂	t ₁
	nom.	max.	min.	min.	min.	min.	nom.	tol.		
C, D	6,3	6,63	6,41	2,5	8,5	8	4	±0,2	—	—
C (D)	10	9,80	9,58	5	12,9	11,5	5,5	±0,2	—	—
C (D)	12,5	13,03	12,76	6	17,1	16	8	±0,3	4	3
D	20	19,44	19,11	6	25,6	24	10,2	±0,3	4	3,5
D	25	25,79	25,46	6,5	34,4	29	15	±0,3	6	4

NOTE It is not recommended that types B and C be used together.

^a Types given in brackets are non-preferred.

4 Separation force

When the male and female squares are locked, the force that shall be applied in order to separate the two parts shall not be less than

- 4 N for the 6,3 mm square,
- 11 N for the 10 mm square,
- 25 N for the 12,5 mm square, and
- 45 N for the 20 mm square.

iTeh STANDARD PREVIEW
(standards.iteh.ai)
ISO 1174-1:2011
<https://standards.iteh.ai/catalog/standards/sist/d0b02e6e-13b9-4e65-8553-c311b9f2a8bd/iso-1174-1-2011>

The force shall be applied gradually along the axis of the squares.

NOTE The values of separation force apply to tools in the delivery condition and to parts supplied by one manufacturer.

5 Designation

A driving square for hand socket tools in accordance with this part of ISO 1174 shall be designated by

- a) “Male square” or “Female square”, as appropriate;
- b) reference to this part of ISO 1174, i.e. ISO 1174-1;
- c) type;
- d) nominal dimension of driving square, in millimetres.

EXAMPLE A male driving square for hand socket tools type A with nominal dimension 12,5 mm is designated as follows:

Male square ISO 1174-1 – A – 12,5

iTeh STANDARD PREVIEW
(standards.iteh.ai)

ISO 1174-1:2011

<https://standards.iteh.ai/catalog/standards/sist/d0b02e6e-13b9-4e65-8553-c311b9f2a8bd/iso-1174-1-2011>