**Graphic technology — Safety
requirements for graphic technology
equipment and systems —**

**Part 3:
Binding and finishing equipment
and systems**

iTeh STANDARD PREVIEW

(standards.iteh.ai)
*Technologie graphique — Exigences de sécurité pour les systèmes
et l'équipement de technologie graphique —*

Partie 3: Systèmes et équipement de reliure et de finissage

ISO 12643-3:2010

<https://standards.iteh.ai/catalog/standards/sist/349f7af4-343d-4126-b399-1e13494d4b7b/iso-12643-3-2010>



PDF disclaimer

This PDF file may contain embedded typefaces. In accordance with Adobe's licensing policy, this file may be printed or viewed but shall not be edited unless the typefaces which are embedded are licensed to and installed on the computer performing the editing. In downloading this file, parties accept therein the responsibility of not infringing Adobe's licensing policy. The ISO Central Secretariat accepts no liability in this area.

Adobe is a trademark of Adobe Systems Incorporated.

Details of the software products used to create this PDF file can be found in the General Info relative to the file; the PDF-creation parameters were optimized for printing. Every care has been taken to ensure that the file is suitable for use by ISO member bodies. In the unlikely event that a problem relating to it is found, please inform the Central Secretariat at the address given below.

iTeh STANDARD PREVIEW
(standards.iteh.ai)

[ISO 12643-3:2010](https://standards.iteh.ai/catalog/standards/sist/349f7af4-343d-4126-b399-1e13494d4b7b/iso-12643-3-2010)

<https://standards.iteh.ai/catalog/standards/sist/349f7af4-343d-4126-b399-1e13494d4b7b/iso-12643-3-2010>



COPYRIGHT PROTECTED DOCUMENT

© ISO 2010

All rights reserved. Unless otherwise specified, no part of this publication may be reproduced or utilized in any form or by any means, electronic or mechanical, including photocopying and microfilm, without permission in writing from either ISO at the address below or ISO's member body in the country of the requester.

ISO copyright office
Case postale 56 • CH-1211 Geneva 20
Tel. + 41 22 749 01 11
Fax + 41 22 749 09 47
E-mail copyright@iso.org
Web www.iso.org

Published in Switzerland

Contents

Page

Foreword	iv
Introduction.....	v
1 Scope	1
2 Normative references	1
3 Terms and definitions	2
4 Conformity with this part of ISO 12643	5
5 Guarding of significant hazards	5
5.1 General	5
5.2 Interlocks.....	5
5.3 Guarding of hoppers and hopper feeders	6
5.4 Guarding on binding and finishing machines	6
5.5 Inserting and collating machines	23
5.6 Counter-stackers	23
5.7 Paper-embossing machines.....	24
5.8 Finishing machines	25
5.9 Guillotine cutters	31
5.10 Trimmers	42
5.11 Onseters/attaching machines	43
5.12 Overcover/protective wrapper gluers.....	43
5.13 Corner-rounding machines	43
6 Information for use	44
6.1 Minimum requirements for machine markings	44
6.2 Contents of instruction handbook.....	44
Annex A (informative) Hazards associated with binding and finishing equipment and systems	48
Annex B (informative) Protection zones against explosion	54
Bibliography.....	56

Foreword

ISO (the International Organization for Standardization) is a worldwide federation of national standards bodies (ISO member bodies). The work of preparing International Standards is normally carried out through ISO technical committees. Each member body interested in a subject for which a technical committee has been established has the right to be represented on that committee. International organizations, governmental and non-governmental, in liaison with ISO, also take part in the work. ISO collaborates closely with the International Electrotechnical Commission (IEC) on all matters of electrotechnical standardization.

International Standards are drafted in accordance with the rules given in the ISO/IEC Directives, Part 2.

The main task of technical committees is to prepare International Standards. Draft International Standards adopted by the technical committees are circulated to the member bodies for voting. Publication as an International Standard requires approval by at least 75 % of the member bodies casting a vote.

Attention is drawn to the possibility that some of the elements of this document may be the subject of patent rights. ISO shall not be held responsible for identifying any or all such patent rights.

ISO 12643-3 was prepared by Technical Committee ISO/TC 130, *Graphic technology*.

This second edition of ISO 12643-3 constitutes a technical revision of the first edition (ISO 12643-3:2008). Significant changes incorporated into this second edition include, but are not limited to, updated requirements for performance levels (PL) or safety integrity levels (SIL) as defined in the current version of ISO 13849-1 and IEC 62061, respectively.

It is the intent of ISO/TC 130 that both the first and second editions of ISO 12643-3 be applicable until 2011-12-31. ISO 12643-3:2008 is thus provisionally retained until this date.

As from 2012-01-01, ISO 12643-3:2010 will cancel and replace ISO 12643-3:2008. Accordingly, as from 2012-01-01, only ISO 12643-3:2010 will be applicable to new equipment manufactured.

ISO 12643 consists of the following parts, under the general title *Graphic technology — Safety requirements for graphic technology equipment and systems*:

- *Part 1: General requirements*
- *Part 2: Prepress and press equipment and systems*
- *Part 3: Binding and finishing equipment and systems*
- *Part 4: Converting equipment and systems*
- *Part 5: Stand-alone platen presses*

Introduction

During the development of this part of ISO 12643, existing relevant standards of other countries were taken into consideration. An effort has been made to harmonize the requirements of all countries, recognizing that national standards or laws may dictate national requirements. In cases where it was known that there is a national requirement that differs from this part of ISO 12643, that has been noted.

This part of ISO 12643 was developed to harmonize the requirements of the following US and European safety standards:

- ANSI B65.2, *Graphic technology — Safety requirements for binding and finishing systems and equipment*
- ANSI B65.3, *Safety standard — Guillotine paper cutters, mill trimmers and integral handling equipment*
- ANSI B65.4, *Safety standard — Three-knife trimmers including rotary, and single- and multiple-knife trimmers*
- EN 1010-1, *Safety of machinery — Safety requirements for the design and construction of printing and paper converting machines — Part 1: Common requirements*
- EN 1010-3, *Safety of machinery — Safety requirements for the design and construction of printing and paper converting machines — Part 3: Cutting machines*
- EN 1010-4, *Safety of machinery — Safety requirements for the design and construction of printing and paper converting machines — Part 4: Bookbinding, paper converting and finishing machines*

<https://standards.iteh.ai/catalog/standards/sist/349f7af4-343d-4126-b399-1e13494d4b7b/iso-12643-3-2010>

iTeh STANDARD PREVIEW
(standards.iteh.ai)

ISO 12643-3:2010

<https://standards.iteh.ai/catalog/standards/sist/349f7af4-343d-4126-b399-1e13494d4b7b/iso-12643-3-2010>

Graphic technology — Safety requirements for graphic technology equipment and systems —

Part 3: Binding and finishing equipment and systems

1 Scope

This part of ISO 12643 provides safety requirements specific to binding and finishing equipment and systems. It is intended to be used in conjunction with the general requirements given in ISO 12643-1.

This part of ISO 12643 provides additional safety requirements for the design and construction of new equipment used to convert printed or blank substrates into cut, folded, collated, assembled, bound, or otherwise finished product. It can also be applicable to processes for preparing substrate for the printing process.

It is applicable to a wide range of equipment used in the binding and finishing process.

iTeh STANDARD PREVIEW
(standards.iteh.ai)

2 Normative references

ISO 12643-3:2010

<https://standards.iteh.ai/catalog/standards/sist/349f7af4-343d-4126-b399-1c1574d4670/iso-12643-3-2010>

The following referenced documents are indispensable for the application of this document. For dated references, only the edition cited applies. For undated references, the latest edition of the referenced document (including any amendments) applies.

ISO 12643-1, *Graphic technology — Safety requirements for graphic technology equipment and systems — Part 1: General requirements*

ISO 13732-1, *Ergonomics of the thermal environment — Methods for the assessment of human responses to contact with surfaces — Part 1: Hot surfaces*

ISO 13849-1, *Safety of machinery — Safety-related parts of control systems — Part 1: General principles for design*

ISO 13857, *Safety of machinery — Safety distances to prevent hazard zones being reached by upper and lower limbs*

ISO 14119, *Safety of machinery — Interlocking devices associated with guards — Principles for design and selection*

ISO 14120, *Safety of machinery — Guards — General requirements for the design and construction of fixed and movable guards*

ISO 14123-1, *Safety of machinery — Reduction of risks to health from hazardous substances emitted by machinery — Part 1: Principles and specifications for machinery manufacturers*

ISO 14123-2, *Safety of machinery — Reduction of risks to health from hazardous substances emitted by machinery — Part 2: Methodology leading to verification procedures*

IEC 62061, *Safety of machinery — Functional safety of safety-related electrical, electronic and programmable electronic control systems*

EN 1539, *Dryers and ovens in which flammable substances are released — Safety requirements*

3 Terms and definitions

For the purposes of this document, the terms and definitions given in ISO 12643-1, ISO 13849-1 and the following apply.

3.1 anti-repeat device
mechanical or electromechanical mechanism that ensures that only one cutting cycle occurs for each manual activation or automatic cut if the primary stopping system or **single-cycle device** (3.33) fails

3.2 automatic cutting sequence
programmed succession of clamping operations and/or cutting movements that is initiated by the operator and proceeds to a specified point without further intervention by the operator

3.3 back-rounding and pressing machine
apparatus for processing book signatures, i.e. for rounding the spine and the trimmed front edge of book signatures and compressing the resulting signatures

3.4 backgauge
movable device (automatic or manual) on a guillotine cutter, positioned square to the cutting table, used to stop the stack of material to be cut when the material is pushed into the opening under the cutting blade by the operator, as well as to determine the dimensions of the cut

3.5 backgauge drive
mechanism to position the **backgauge** (3.4) prior to the initiation of the cut

3.6 backlining and head-banding machines
<hard-cover bookbinding> equipment for the automatic production of hard-cover books where the binding together of the signatures is rounded or flat, with glue, gauze, or paper

3.7 book cover crease forming machine
<hard-cover bookbinding> apparatus for creating, under heat and pressure, a permanent bend in the cover of a hard-cover book, then pressing the entire cover surface

3.8 book press
device used for flattening books

3.9 book signature press
power-operated device used for flattening book signatures, which are fed and aligned manually

3.10 casing-in machine
<hard-cover bookbinding> apparatus for gluing the end papers of the book signatures to the interior surfaces of the book cover

3.11**clamp**

device using pressure to secure product so that it does not move during an operation

3.12**clamp drive**

mechanism by which the **clamp(s)** (3.11) of the paper cutter is (are) forced against the material to be cut

3.13**coater**

finishing machine that applies a predetermined thickness of a liquid substance (e.g. glue, varnish, ink) on substrates made of paper or a similar material

3.14**counter-stacker**

machine for stacking piles of leaflets, books, magazines or newspapers such that the successive layers are positioned at 180° to the previous layer

3.15**cutting cycle**

(machines with (a) manually driven **clamp(s)** (3.11)) programmed succession of operations that begins when the knife drive is activated and ends when the knife returns to its retracted position

3.16**cutting cycle**

(machines with (a) power-driven **clamp(s)** (3.11)) programmed succession of operations that begins when high-pressure clamping is initiated and ends when the knife(knives) and clamp(s) return to their retracted positions after a single clamp/knife stroke

3.17**cutting zone**

three-dimensional space through which any part of the knife(knives) and/or **clamp(s)** (3.11) travels during the entire **cutting cycle** (3.16)

3.18**gang stitcher**

machine for stitching folded sheets of paper, during the operation in which individual folded sheets are removed by feeding grippers and the open sheets are stacked on top of each other on a transport chain for subsequent back-stitching

3.19**gathering machine**

apparatus that assembles sheets or folded sheets in a binding line

3.20**guillotine cutter**

power-driven machine having a single knife that is used primarily to cut paper products, stacks of paper, or other substrates, as specified by the manufacturer

NOTE This definition includes equipment classified as mill trimmers.

3.21**high-pressure clamping**

operation of **clamp(s)** (3.11) with a dynamic force in excess of 300 N for machines up to and including 1,6 m in width, or in excess of 500 N for machines greater than 1,6 m in width, when measured at 75 % of the clamp opening (e.g. with the clamp at 25 % of its maximum travel distance measured from the retracted position)

NOTE The 75 % value is to ensure that the measurement is made at the position that approximates to the size of an operator's hand.

3.22

inserting machine

apparatus that inserts printed matter such as leaflets and magazines at a predetermined position in other printed products, such as newspapers or magazines

3.23

knife drive

mechanism by which the knife of the guillotine is forced through the material to be cut

3.24

laminator

paper-finishing machine that applies a solid material (e.g. foil, paper) to a substrate made of paper or a similar material

3.25

low-pressure clamping

(for machines with (a) power-driven **clamp(s)** (3.11)) operation of clamps with a dynamic force not exceeding 300 N for machines up to and including 1,6 m in width, or not exceeding 500 N for machines greater than 1,6 m in width, when measured at 75 % of the clamp opening (with the clamp at 25 % of its maximum travel measured from the retracted position)

NOTE The 75 % value is to ensure that the measurement is made at the position that approximates to the size of an operator's hand.

3.26

manual clamping

operation of **clamp(s)** (3.11) in which the dynamic and static forces and motion of the clamp are directly supplied by the operator

3.27

paper drill

machine used to drill holes into piles of paper

ITeCh STANDARD PREVIEW
(standards.iteh.ai)
ISO 12643-3:2010
<https://standards.iteh.ai/catalog/standards/sist/349f7af4-343d-4126-b399-1e13494d4b7b/iso-12643-3-2010>

3.28

paper-embossing machine

machine for finishing paper surfaces by using cylinders to press a design in relief into the paper

3.29

paper-finishing machine

apparatus used for applying liquid or solid coating material to a substrate made of paper or a similar material

3.30

perfect binder

machine for the automatic production of brochures (soft-cover) or book signatures (hard-cover) where gathered folded sheets or single sheets are bound to form book or brochure signatures by applying glue on the pre-processed book back, and where book or brochure signatures are inserted into covers by gluing the cover on the back and/or sides

3.31

safety distance

minimum distance a protective device is required to be placed from a hazard zone

3.32

sheet-folding machine

apparatus to cut, perforate and/or crease single or multiple folds in single sheets of paper

3.33

single-cycle device

mechanism that ensures that only one cutting cycle occurs for each manual activation or automatic cut

NOTE See **anti-repeat device** (3.1).

3.34**stored energy**

potential energy that may be released without actuation of the machine drive or controls

4 Conformity with this part of ISO 12643

In order to claim conformity with this part of ISO 12643, all equipment manufactured as of 2012-01-01 shall be in accordance with this second edition of ISO 12643 rather than ISO 12643-3:2008.

5 Guarding of significant hazards**5.1 General**

Guarding, consistent with operation of the machine, shall be provided in those areas where it is recognized that operators are exposed to significant hazards. The guarding requirements of ISO 12643-1 apply. See Annex A for a list of hazards associated with binding and finishing equipment and systems.

5.2 Interlocks**5.2.1 Exception for machine motion at inching speed**

If a machine is operating at inching speed and under conditions defined in ISO 12643-1, motion may continue when an interlocked guard is opened.

5.2.2 Exception for machine motion at production speed

This exception shall apply only to the specific machines identified in this part of ISO 12643 and does not apply to all equipment.

NOTE This exception might not comply with current European standards or the Machinery Directive^[9,10].

There might be parts of the equipment that cannot be observed or adjusted with the guard closed and need to be accessed by an authorized person with an interlocked guard open. Under these circumstances, the following alternative safety measures shall be taken:

- a) A mechanical key lock shall be provided adjacent to the access area. There shall be only one key for this lock. The key for this lock shall be accessible only by an authorized person.
- b) The key lock shall operate as a hold-to-run device as follows:
 - 1) inserting the key shall initiate a timer that has a maximum setting of 2 min;
 - 2) turning the key shall override the guard interlock of only that guard, up to the preset time limit;
 - 3) as long as the key is held in the turned position, the guard may be opened with machine motion at production speed until such time as the timer reaches the preset time limit;
 - 4) when the key is released, it shall automatically return to the neutral position and the guard interlock shall be automatically reactivated;
 - 5) if the key remains in the lock for a period longer than the preset time limit (which shall not exceed 2 min), the interlock on the guard shall be reactivated automatically and the equipment safety system shall stop machine motion.
- c) The bypassing means shall meet the requirements of PL_r d of ISO 13849-1 or SIL 2 of IEC 62061.

- d) When adjustments are necessary, they shall be performed from outside the hazardous area.
- e) A safety label identifying the possible existing hazards with the guard open shall be provided adjacent to the lock. The label shall clearly indicate that, when the key is in the lock, the adjacent guard is overridden.

If a machine is equipped with this alternative safety measure, information regarding its safe use shall be contained in the instruction handbook.

5.3 Guarding of hoppers and hopper feeders

5.3.1 Manually loaded hoppers

On machines using manually loaded hoppers, the hazard points on the separating elements of the hopper feeder shall be safeguarded in accordance with 5.3.4. The exception defined in 5.2.2 may be applied to the hopper feeder, if necessary.

5.3.2 Guarding of automatically fed hoppers

On automatically fed hoppers where manual intervention during normal operation is not required and the material used makes access difficult, tunnel-type guards arranged with a safety distance of 550 mm from the nearest hazard point are considered adequate.

The exception defined in 5.2.2 may be applied to the hopper feeder, if necessary.

5.3.3 Protection of unused hoppers and hopper feeders

For hoppers that are not used and cannot be stopped, blanking boards shall be provided to safeguard the hazard points at the separating elements.

5.3.4 Separating elements on hopper feeders

The hazard points on separating elements outside the sidelays on feeders shall be safeguarded for every format size used.

For hazard points within sidelays, residual-pile monitoring that complies with PL_r b of ISO 13849-1 or SIL 1 of IEC 62061 shall be used.

NOTE This safeguarding can be achieved, for example, by product, by using accordion-type bellows or by the use of additional guards.

5.4 Guarding on binding and finishing machines

5.4.1 Hand-fed riveting, eyeletting and attaching machines

Hazard points between tools on riveting, eyeletting and attaching machines either shall be prevented by design or shall be safeguarded.

Means to satisfy this requirement include, but are not limited to, the following:

- observing a maximum distance of 4 mm between the tools in the open position;
- ensuring that the closing force of the movable tool is less than 50 N; a stronger closing force is allowed to become effective only after a sensing device has confirmed that no part of a human body is located between the two tools.

NOTE The sensing device function, for example, can be based on the fact that the workpiece and a body part have different electrical resistances or different thicknesses.

Hazard points are safeguarded if guards are provided in accordance with ISO 13857 or the machine can be started only by two-hand control.

For machines that are not guarded by a fixed or movable guard, a workpiece support shall be provided, and two-hand controls meeting the requirements of ISO 12643-1 shall be used. If the workpiece needs to be held by hand outside the hazard zone, a hold-to-run control shall be provided for starting the machine instead of the two-hand control.

5.4.2 Hand-fed flat- and saddle-stitching machines

Adjustable guards shall be provided on flat-stitching, saddle-stitching and combination-stitching machines for operational reasons (see Figure 1 and Figure 2). Instructions that describe the safe adjustment of the guards in a clear and easily understandable format shall be provided on the machine.

NOTE This marking requirement is satisfied, for example, by providing labels that illustrate the safety distances required for the various stitching thicknesses by means of sketches and measurements.

On combination-stitching machines in the saddle-stitching mode, the guard for the upper tool shall extend to the height of the upper edge of the lower tool (upper edge of the saddle) and shall enclose the upper tool to prevent inadvertent access (see Figure 2).

Guarding may be by either two separate guards or a combined reversible guard. Combined reversible guards shall be suitable for saddle stitching as well as for flat stitching.

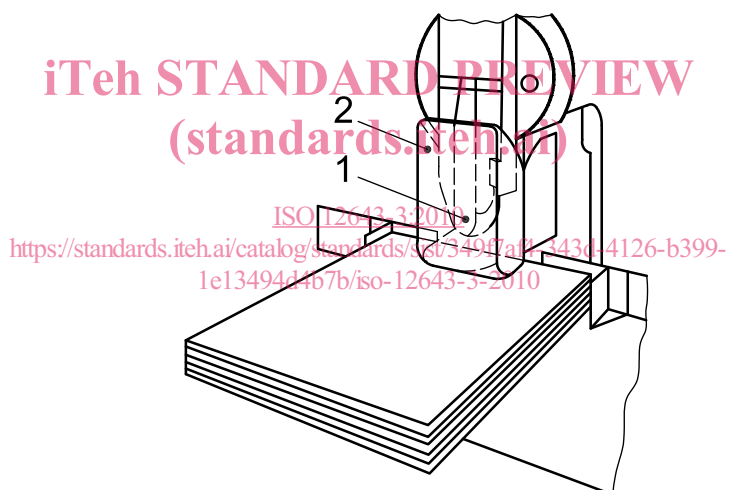

Key

- 1 upper tool
- 2 guard

Figure 1 — Flat stitcher

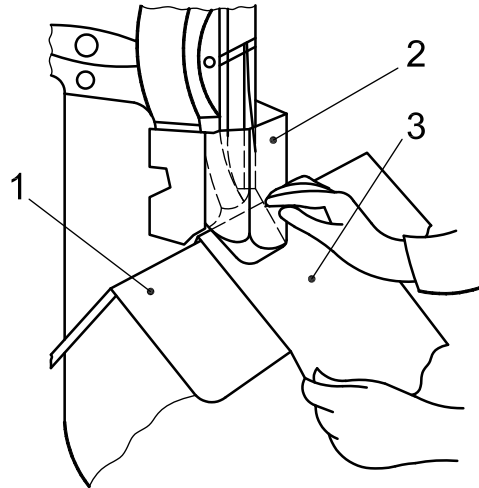

Key

- 1 upper edge of saddle
- 2 guard
- 3 workpiece

iTeh STANDARD PREVIEW
Figure 2 — Saddle stitcher
(standards.iteh.ai)

5.4.3 Gang stitchers and drum stitchers

[ISO 12643-3:2010](#)

5.4.3.1 Feeders on gang stitchers and drum stitchers

<https://standards.iteh.ai/catalog/standards/sist/349f7af4-343d-4126-b399-1e13494d467b/iso-12643-3-2010>

Depending on the design, fixed guards, movable guards, residual-pile monitoring or other means of guarding may be used (see Figure 3).

Where the bottom of the feeder on the transport channel side (see Figure 4) needs to remain open for functional reasons, the lower edges of the guards on the transport channel side shall be extended as low as technically feasible.

EXAMPLE An example of a “functional reason” would be for the use of air vortexes.

The exception defined in 5.2.2 may be applied to the feeder, if necessary.

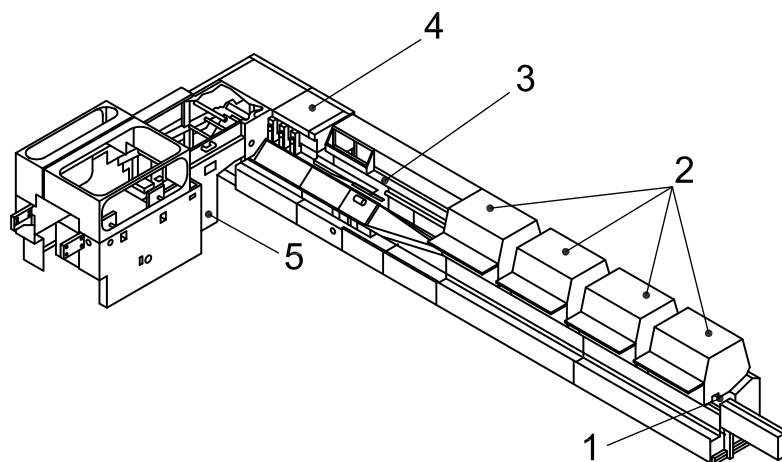

Key

- 1 transport chain
- 2 feeder
- 3 thickness control
- 4 stitching unit
- 5 trimmer

iTeh STANDARD PREVIEW
Figure 3 — Gang stitcher
(standards.iteh.ai)

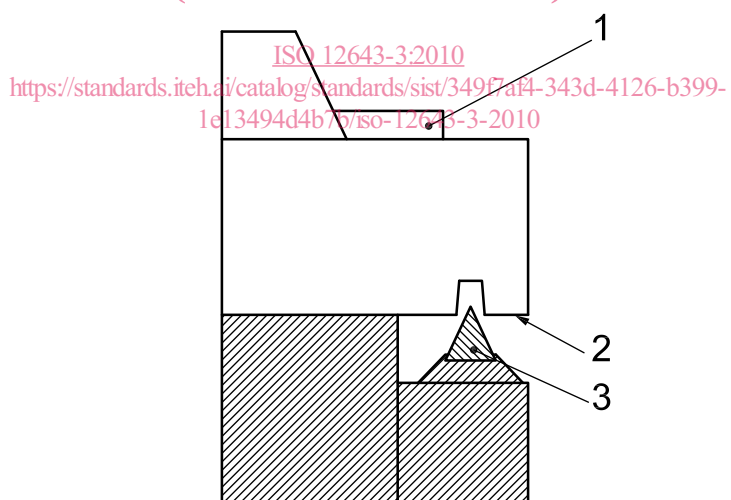

Key

- 1 hopper
- 2 bottom of feeder
- 3 transport chain

Figure 4 — Feeder