**Self-propelled machinery for forestry —
Laboratory tests and performance
requirements for roll-over protective
structures —**

Part 1:
General machines

iTeh STANDARD PREVIEW

(standards.iteh.ai)
*Machines forestières automotrices — Essais de laboratoire et
exigences de performance pour les structures de protection au
retournement —*

ISO 8082-1:2009
Partie 1. Machines communes

[https://standards.iteh.ai/catalog/standards/sist/adc4c262-61f1-4bd3-bb32-
ea33d64bbb40/iso-8082-1-2009](https://standards.iteh.ai/catalog/standards/sist/adc4c262-61f1-4bd3-bb32-ea33d64bbb40/iso-8082-1-2009)



PDF disclaimer

This PDF file may contain embedded typefaces. In accordance with Adobe's licensing policy, this file may be printed or viewed but shall not be edited unless the typefaces which are embedded are licensed to and installed on the computer performing the editing. In downloading this file, parties accept therein the responsibility of not infringing Adobe's licensing policy. The ISO Central Secretariat accepts no liability in this area.

Adobe is a trademark of Adobe Systems Incorporated.

Details of the software products used to create this PDF file can be found in the General Info relative to the file; the PDF-creation parameters were optimized for printing. Every care has been taken to ensure that the file is suitable for use by ISO member bodies. In the unlikely event that a problem relating to it is found, please inform the Central Secretariat at the address given below.

iTeh STANDARD PREVIEW
(standards.iteh.ai)

ISO 8082-1:2009

<https://standards.iteh.ai/catalog/standards/sist/ade4c262-b1f1-4bd3-bb32-ea33d64bbb40/iso-8082-1-2009>



COPYRIGHT PROTECTED DOCUMENT

© ISO 2009

All rights reserved. Unless otherwise specified, no part of this publication may be reproduced or utilized in any form or by any means, electronic or mechanical, including photocopying and microfilm, without permission in writing from either ISO at the address below or ISO's member body in the country of the requester.

ISO copyright office
Case postale 56 • CH-1211 Geneva 20
Tel. + 41 22 749 01 11
Fax + 41 22 749 09 47
E-mail copyright@iso.org
Web www.iso.org

Published in Switzerland

Contents

Page

Foreword	iv
1 Scope	1
2 Normative references	1
3 Terms, definitions and symbols	2
4 Static laboratory tests	4
5 Performance requirements	11
6 Reporting results	13
Annex A (normative) Test report for ISO 8082-1	14
Bibliography	16

iTeh STANDARD PREVIEW
(standards.iteh.ai)

ISO 8082-1:2009

<https://standards.iteh.ai/catalog/standards/sist/ade4c262-b1f1-4bd3-bb32-ea33d64bbb40/iso-8082-1-2009>

Foreword

ISO (the International Organization for Standardization) is a worldwide federation of national standards bodies (ISO member bodies). The work of preparing International Standards is normally carried out through ISO technical committees. Each member body interested in a subject for which a technical committee has been established has the right to be represented on that committee. International organizations, governmental and non-governmental, in liaison with ISO, also take part in the work. ISO collaborates closely with the International Electrotechnical Commission (IEC) on all matters of electrotechnical standardization.

International Standards are drafted in accordance with the rules given in the ISO/IEC Directives, Part 2.

The main task of technical committees is to prepare International Standards. Draft International Standards adopted by the technical committees are circulated to the member bodies for voting. Publication as an International Standard requires approval by at least 75 % of the member bodies casting a vote.

Attention is drawn to the possibility that some of the elements of this document may be the subject of patent rights. ISO shall not be held responsible for identifying any or all such patent rights.

ISO 8082-1 was prepared by Technical Committee ISO/TC 23, *Tractors and machinery for agriculture and forestry*, Subcommittee SC 15, *Machinery for forestry*.

This first edition of ISO 8082-1 cancels and replaces ISO 8082:2003, of which it constitutes a minor revision. Whereas machines having a rotating platform with cab and boom on the platform remain excluded from the scope of this part of ISO 8082, the restructuring of the standard into discrete parts allows those machines to be addressed in ISO 8082-2.

<https://standards.iteh.ai/catalog/standards/sist/4e4262-b1f1-4bd3-bb32-ea33d64b1b40/iso-8082-1-2009>

ISO 8082 consists of the following parts, under the general title *Self-propelled machinery for forestry — Laboratory tests and performance requirements for roll-over protective structures*:

- *Part 1: General machines*
- *Part 2: Machines having a rotating platform with a cab and boom on the platform*

Self-propelled machinery for forestry — Laboratory tests and performance requirements for roll-over protective structures —

Part 1: General machines

1 Scope

This part of ISO 8082 establishes a consistent, reproducible means of evaluating the force–deflection characteristics of roll-over protective structures (ROPS) on self-propelled forestry machines under static loading, and prescribes performance requirements for a representative specimen under such loading. It is applicable to forwarders, skidders, feller-bunchers, processors, harvesters and log loaders, as defined in ISO 6814. It is not applicable to machines having a rotating platform with a cab and boom on the platform, which are addressed by ISO 8082-2.

NOTE The requirement levels and testing procedures of this part of ISO 8082 are the same as those of ISO 3471 [2].

2 Normative references

The following referenced documents are indispensable for the application of this document. For dated references, only the edition cited applies. For undated references, the latest edition of the referenced document (including any amendments) applies.

ISO 148-1, *Metallic materials — Charpy pendulum impact test — Part 1: Test method*

ISO 898-1, *Mechanical properties of fasteners made of carbon steel and alloy steel — Part 1: Bolts, screws and studs with specified property classes — Coarse thread and fine pitch thread*

ISO 898-2:1992, *Mechanical properties of fasteners — Part 2: Nuts with specified proof load values — Coarse thread*

ISO 3164, *Earth-moving machinery — Laboratory evaluations of protective structures — Specifications for deflection-limiting volume*

ISO 6814, *Machinery for forestry — Mobile and self-propelled machinery — Terms, definitions and classification*

3 Terms, definitions and symbols

For the purposes of this document, the following terms, definitions and symbols (see Table 1) apply.

3.1

roll-over protective structure ROPS

system of structural members whose primary purpose is to reduce the possibility of a seat-belted operator being crushed should the machine roll over

NOTE These structural members include any subframe, bracket, mounting, socket, bolt, pin, suspension or flexible shock absorber used to secure the system to the machine frame, but exclude mounting provisions that are integral with the machine frame.

3.2

deflection-limiting volume DLV

orthogonal approximation of a large, seated, male operator as defined in ISO 3411 wearing normal clothing and a protective helmet

3.3

falling-object protective structure FOPS

system of structural members arranged in such a way as to provide operators with reasonable protection from falling objects (e.g. trees, rocks)

3.4

operator protective structure OPS

system of structural members arranged in such a way as to minimize the possibility of operator injury from penetrating objects (such as whipping saplings, branches and broken winch lines)

3.5

simulated ground plane SGP

flat surface on which, after rolling, a forestry machine is assumed to come to rest

3.5.1

lateral simulated ground plane LSGP

for a machine coming to rest on its side, the plane 15° away from the DLV about the horizontal axis within the plane established in the vertical plane passing through the outermost point

See Figure 1.

NOTE The LSGP is established on an unloaded ROPS and moves with the member to which load is applied while maintaining its 15° angle with respect to the vertical.

3.5.2

vertical simulated ground plane VSGP

⟨rollbar ROPS⟩ for a machine coming to rest in an upside-down position, the plane defined by the top cross-member of the ROPS and that front (or rear) part of the machine likely to come in contact with flat ground at the same time as the ROPS and capable of supporting the upside-down machine

NOTE The VSGP moves with the deformed ROPS.

3.6 machine mass

m

maximum mass declared by the manufacturer, including attachments in the operating condition and with tools, ROPS and all reservoirs filled, but excluding towed equipment (e.g. chippers, planters, discs) and any load that could be carried on the machine

Table 1 — Symbols

Symbol	Description	Unit
U	Energy absorbed by the structure, related to machine mass	J
F	Force	N
m	Machine mass	kg
Δ	Deflection of ROPS	mm

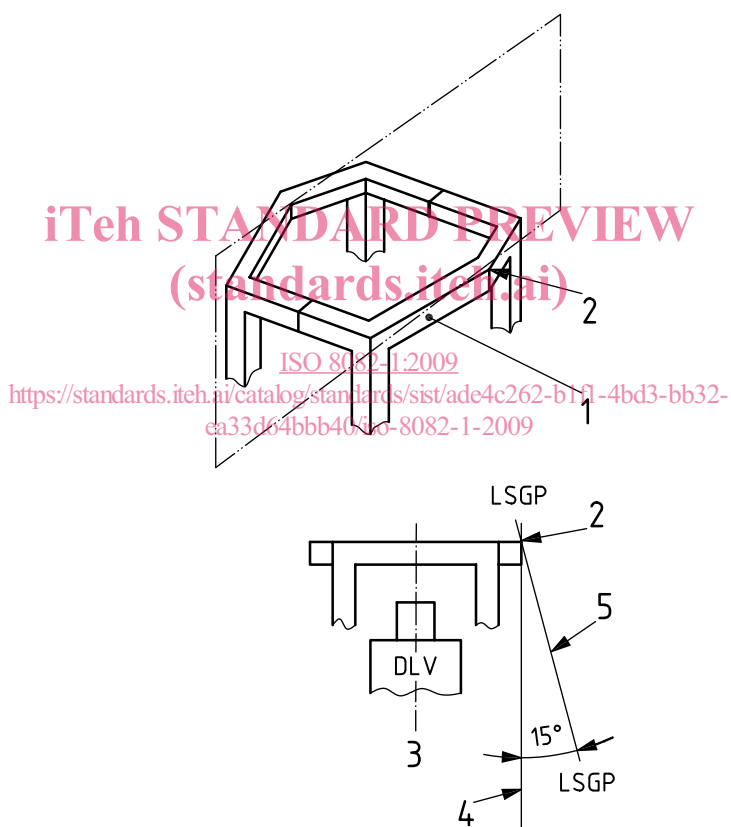

Key

- 1 upper ROPS member to which the lateral load is applied
- 2 outermost point from the end view of member (1)
- 3 vertical plane parallel to the machine longitudinal centreline through line (4)
- 4 vertical line through point (2)
- 5 lateral simulated ground plane

Figure 1 — Determination of lateral simulated ground plane (LSGP)

4 Static laboratory tests

CAUTION — Some of the tests specified in this part of ISO 8082 involve the use of processes which could lead to a hazardous situation.

4.1 Facilities

Facilities for securing the ROPS/machine frame assembly to the bedplate, as specified in the following, and for applying lateral, longitudinal and vertical loads, shall be provided.

The DLV and its location shall be in accordance with ISO 3164. The DLV shall be fixed firmly to the same part of the machine to which the operator's seat is normally secured, and shall remain there during the entire formal test period. For machines with a reversible operator's position, the DLV is to be considered as the combined clearance zones for the two positions.

4.2 Instruments

The test apparatus shall be equipped with instruments for measuring the force applied to the protective structure and the deflection (deformation) of the structure. The instrument accuracy shall be in accordance with Table 2.

Table 2 — Instrument accuracy requirements

Measurement	Accuracy ^a
Deflection of ROPS	± 5 % of maximum deflection measured
Force applied to ROPS	± 5 % of maximum force measured

^a The percentages are nominal ratings of the accuracy of the instrumentation and shall not be taken to indicate that a compensating overtest is required.

<https://standards.iteh.ai/catalog/standards/sist/ade4c262-b1f1-4bd3-bb32-ea33d64bbb40/iso-8082-1-2009>

4.3 Apparatus

4.3.1 General

4.3.1.1 Assembly of ROPS to machine frame

The ROPS shall be attached to the machine frame or body as it would be on an operating machine. A complete machine is not required for the evaluation; however, the machine frame or body and ROPS mounting shall represent an operating installation. All normally detachable windows, panels, doors and other non-structural elements shall be removed so that they neither contribute to, nor detract from, the structural evaluation.

4.3.1.2 ROPS/machine attachment to bedplate

The ROPS/machine-frame assembly shall be secured to the bedplate so that the members connecting the assembly and bedplate experience minimal deflection during testing. During lateral loading, the ROPS/machine-frame assembly shall not receive any support from the bedplate, other than that due to the initial attachment.

Connections to the bedplate shall be directly from the machine frame at or near the front-axle support and the rear drive support. For articulated machines, if both frames are used in the evaluation, the hinge shall be locked so that the frames are in a straight line. If the frame on which the ROPS is mounted is used alone, the connections shall be at or near the extreme ends of the frame (see Figure 2).

4.3.1.3 Elimination of energy absorbers

The assembly shall be secured or modified or both so that any machine element that might be considered as suspension (rubber, gas, gas-oil or mechanical spring) shall be effectively eliminated as an energy absorber. However, the ROPS-structural members may include suspension or flexible shock absorbers, which shall not be altered.

4.3.2 Vertical loading

For vertical loading, there is no limitation on securing or supporting the ROPS/machine-frame assembly, except that no repair or straightening of the assembly shall be carried out.

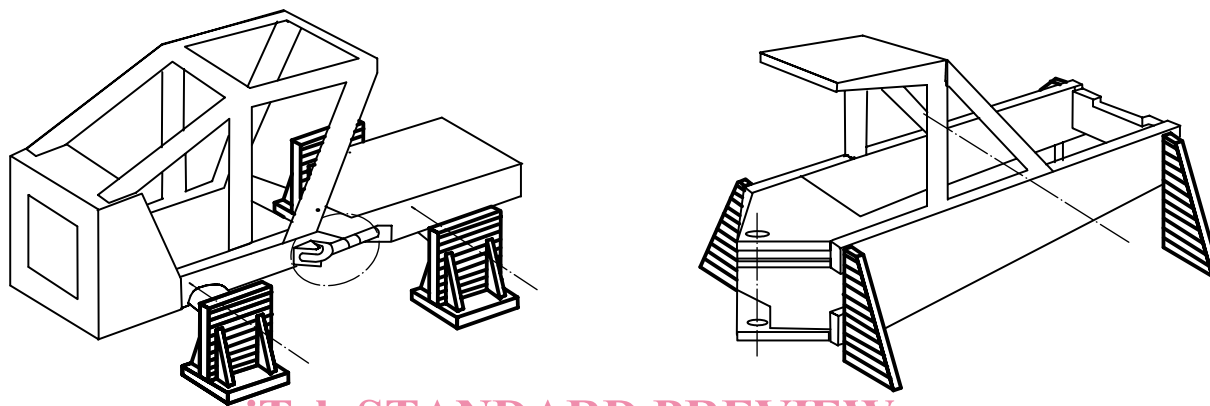

iTeh STANDARD PREVIEW

(standards.itech.ai)
Figure 2 — Machine attachment to bedplate

ISO 8082-1:2009

4.4 Test procedures

4.4.1 General

The test procedures shall consist of the operations specified in 4.4.2 (lateral loading), 4.4.3 (vertical loading) and 4.4.4 (longitudinal loading), carried out in that order.

No repair or straightening of any ROPS/machine member shall be carried out during or between the lateral, vertical and longitudinal loading.

NOTE The figures referred to are illustrative and not intended to restrict the design of loading devices.

4.4.2 Lateral loading

4.4.2.1 The force–deflection characteristics shall be determined by lateral loading of the top major longitudinal members of the ROPS.

4.4.2.2 For a ROPS having more than two posts, the lateral loading shall be applied through a load-distribution device having a length not greater than 80 % of the horizontal distance, L , between the front and rear posts of the ROPS (see Figure 3). In the case of curved structural members, the load-distribution device may be attached to the ROPS but shall not have any affect on the strength of the ROPS.

4.4.2.3 For all one- or two-post ROPS, initial loading shall be dictated by the length, L , and the vertical projections of the front and rear planes of the DLV. The load application point may not be within $L/3$ of the ROPS structure. Should the $L/3$ point be between the vertical projection of the DLV and the ROPS structure, the load application point shall be moved away from the structure until it enters the vertical projection of the DLV (see Figure 4).

4.4.2.4 The initial direction of loading shall be horizontal and perpendicular to a vertical plane through the machine's longitudinal centreline. As loading continues, the ROPS/machine-frame deformations can cause the direction of loading to change: this is permissible.

4.4.2.5 If the operator's seat is off the machine's longitudinal centreline, the loading shall be against the outermost side nearest the seat. For on-centreline seats, if mounting of the ROPS is such that different force-deflection relations are obtained from loading from left or right, the side loaded shall be that which will place the most severe requirements on the ROPS/machine assembly.

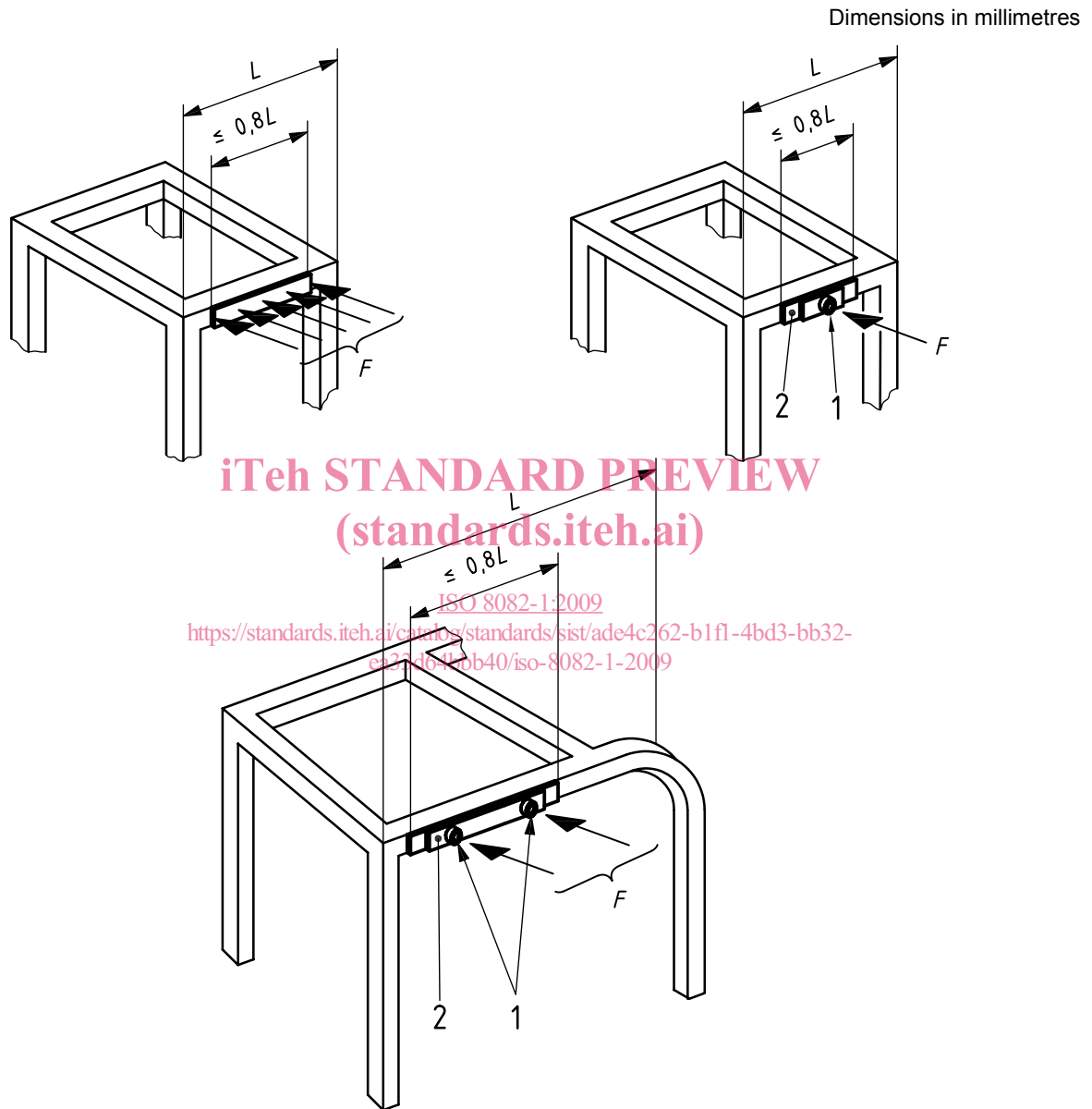

Key

- 1 socket
- 2 load distributor

NOTE 1 The load distributor and socket are to prevent local penetration and to hold the end of the load-generating device.

NOTE 2 Typical, but not mandatory, layout.

Figure 3 — Load-distribution device for ROPS with four-post system

4.4.2.6 The rate of application of deflection (load) shall be such that it can be considered static, i.e. a speed of < 5 mm/s. At deflection increments no greater than 15 mm at the point of application of the resultant load, the force and deflection shall be recorded and plotted. The loading shall be continued until the ROPS has achieved both the force and energy requirements. The area under the resulting force–deflection curve equals the energy (see Figure 5). The deflection or deflections used in calculating energy shall be that of the ROPS along the line(s) of action of the force(s). Any deflection of members used to support load-application devices shall not be included in deflection measurements used for the calculation of energy.

Dimensions in millimetres

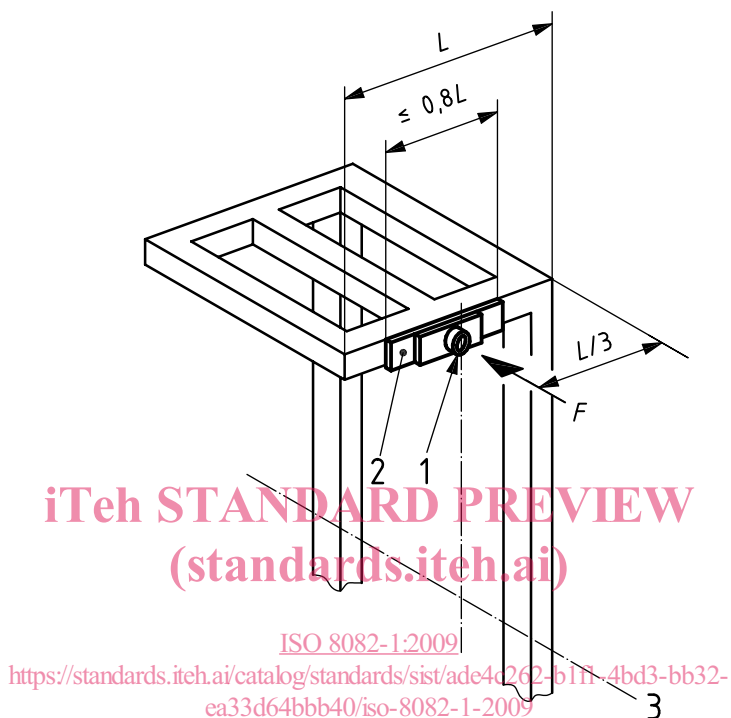

Key

- 1 socket
- 2 load distributor
- 3 locating axis (LA) of DLV

Figure 4 — Load-distribution device for ROPS with two-post system