Tissue paper and tissue products —
Part 8:
Water-absorption time and
water-absorption capacity,
basket-immersion test method

iTeh STANDARD PREVIEW
(standards.iteh.ai)

Papier tissue et produits tissues —

*Partie 8: Temps d'absorption d'eau et capacité d'absorption d'eau,
méthode d'essai d'immersion au panier*

ISO 12625-8:2010

<https://standards.iteh.ai/catalog/standards/sist/c73a1519-54fd-48bb-99d1-19276bd4587e/iso-12625-8-2010>



PDF disclaimer

This PDF file may contain embedded typefaces. In accordance with Adobe's licensing policy, this file may be printed or viewed but shall not be edited unless the typefaces which are embedded are licensed to and installed on the computer performing the editing. In downloading this file, parties accept therein the responsibility of not infringing Adobe's licensing policy. The ISO Central Secretariat accepts no liability in this area.

Adobe is a trademark of Adobe Systems Incorporated.

Details of the software products used to create this PDF file can be found in the General Info relative to the file; the PDF-creation parameters were optimized for printing. Every care has been taken to ensure that the file is suitable for use by ISO member bodies. In the unlikely event that a problem relating to it is found, please inform the Central Secretariat at the address given below.

iTeh STANDARD PREVIEW
(standards.iteh.ai)

[ISO 12625-8:2010](https://standards.iteh.ai/catalog/standards/sist/c73a1519-54fd-48bb-99d1-19276bd4587e/iso-12625-8-2010)

<https://standards.iteh.ai/catalog/standards/sist/c73a1519-54fd-48bb-99d1-19276bd4587e/iso-12625-8-2010>



COPYRIGHT PROTECTED DOCUMENT

© ISO 2010

All rights reserved. Unless otherwise specified, no part of this publication may be reproduced or utilized in any form or by any means, electronic or mechanical, including photocopying and microfilm, without permission in writing from either ISO at the address below or ISO's member body in the country of the requester.

ISO copyright office
Case postale 56 • CH-1211 Geneva 20
Tel. + 41 22 749 01 11
Fax + 41 22 749 09 47
E-mail copyright@iso.org
Web www.iso.org

Published in Switzerland

Foreword

ISO (the International Organization for Standardization) is a worldwide federation of national standards bodies (ISO member bodies). The work of preparing International Standards is normally carried out through ISO technical committees. Each member body interested in a subject for which a technical committee has been established has the right to be represented on that committee. International organizations, governmental and non-governmental, in liaison with ISO, also take part in the work. ISO collaborates closely with the International Electrotechnical Commission (IEC) on all matters of electrotechnical standardization.

International Standards are drafted in accordance with the rules given in the ISO/IEC Directives, Part 2.

The main task of technical committees is to prepare International Standards. Draft International Standards adopted by the technical committees are circulated to the member bodies for voting. Publication as an International Standard requires approval by at least 75 % of the member bodies casting a vote.

Attention is drawn to the possibility that some of the elements of this document may be the subject of patent rights. ISO shall not be held responsible for identifying any or all such patent rights.

ISO 12625-8 was prepared by the European Committee for Standardization (CEN) Technical Committee CEN/TC 172, *Pulp, paper and board*, in collaboration with Technical Committee ISO/TC 6, *Paper, board and pulps*, Subcommittee SC 2, *Test methods and quality specifications for paper and board*, in accordance with the Agreement on technical cooperation between ISO and CEN (Vienna Agreement).

This second edition cancels and replaces the first edition (ISO 12625-8:2006), which has been technically revised.

<https://standards.iteh.ai/catalog/standards/cist/c73a1510-5461-48bb-99d1-10276bd45877/iso-12625-8-2010>

The essential change in this International Standard is the separation of the so-called “manual method” and the excluding of the “automated method”. For more details see the Introduction.

ISO 12625 consists of the following parts, under the general title *Tissue paper and tissue products*:

- *Part 1: General principles for the use of terms*
- *Part 3: Determination of thickness, bulking thickness and apparent bulk density*
- *Part 4: Determination of tensile strength, stretch at break and tensile energy absorption*
- *Part 5: Determination of wet tensile strength*
- *Part 6: Determination of grammage*
- *Part 7: Determination of optical properties — Measurement of brightness and colour*
- *Part 8: Water-absorption time and water-absorption capacity, basket-immersion test method*
- *Part 9: Determination of ball burst strength*
- *Part 12: Determination of tensile strength of perforated lines — Calculation of perforation efficiency*

Introduction

This part of ISO 12625 describes one principle for the determination of water-absorption properties of tissue paper and tissue products, a principle in which sheets of the sample are inserted in a cylindrical basket, which is immersed in water. The results are expressed as

- water-absorption time, and
- water-absorption capacity.

In European and international trade, both water-absorption time and water-absorption capacity represent important parameters in the field of comparison of tissue products.

Both manual and automated methods exist, but the procedure described in this part of ISO 12625 refers to manual devices only. The reason is that precision results obtained with the different automatic methods included in an interlaboratory study were not acceptable compared with the results obtained using the manual testing method.

Nevertheless, automated test methods may be used, provided that they can be shown to give the same results as the manual method, in terms of average values and standard deviations.

iTeh STANDARD PREVIEW
(standards.iteh.ai)

[ISO 12625-8:2010](https://standards.iteh.ai/catalog/standards/sist/c73a1519-54fd-48bb-99d1-19276bd4587e/iso-12625-8-2010)

<https://standards.iteh.ai/catalog/standards/sist/c73a1519-54fd-48bb-99d1-19276bd4587e/iso-12625-8-2010>

Tissue paper and tissue products —

Part 8:

Water-absorption time and water-absorption capacity, basket-immersion test method

1 Scope

This part of ISO 12625 specifies a basket-immersion test method for the determination of water-absorption time and water-absorption capacity of tissue paper and tissue products.

It is expressly stated that the detection of impurities and contraries in tissue paper and tissue products be applied according to ISO 15755.

For the determination of moisture content in tissue paper and tissue products, ISO 287 is applicable.

2 Normative references

The following referenced documents are indispensable for the application of this document. For dated references, only the edition cited applies. For undated references, the latest edition of the referenced document (including any amendments) applies.

ISO 186, *Paper and board — Sampling to determine average quality*

ISO 187, *Paper, board and pulps — Standard atmosphere for conditioning and testing and procedure for monitoring the atmosphere and conditioning of samples*

ISO 14487, *Pulps — Standard water for physical testing*

3 Terms and definitions

For the purposes of this document, the following terms and definitions apply.

3.1

absorption time

time required for complete wetting of a sample

3.2

water-absorption capacity

mass of water that is absorbed per unit mass of the test piece under specified conditions

4 Principle

A test piece of the tissue paper or a tissue product is placed in a cylindrical basket and allowed to immerse in water under its own weight.

The time required for complete wetting of the test piece is measured, the mass of water absorbed then being determined after a stated immersion time followed by a given draining time, under specified conditions.

5 Reagent

5.1 Deionized water, with a conductivity $\leq 0,25$ mS/m at 25 °C, in accordance with ISO 14487. The water temperature should be maintained during the test at the temperature used for conditioning and testing. To avoid interference due to contamination of the water from previous test pieces, change the water after each series of tests.

6 Preparation and conditioning of the test pieces

6.1 Sampling

If the tests are being made to evaluate a lot, select the sample in accordance with ISO 186. When sampling finished roll products, eliminate at least the first six layers and the last six layers because of the possible presence of adhesive or mechanical damage.

If the tests are made on another type of sample, make sure that the test pieces taken are representative of the sample received.

6.2 Conditioning

Condition the test pieces in accordance with ISO 187.

6.3 Preparation of test pieces

From the sample, prepare five test pieces by cutting test pieces of (76 ± 1) mm width and with the length in the machine direction sufficient for the mass of each test piece to be $(5,0 \pm 0,2)$ g.

When preparing test pieces comprising a number of superimposed sheets, all individual sheets shall have the same face up.

If several sheets are cut at once, separate them before testing.

Record the mass of each test piece, m_0 , in grams, to two decimal places.

Other test piece sizes could be agreed between the parties concerned. If another test piece size is used, the dimensions shall be reported in the test report.

7 Manual test method

7.1 Apparatus

7.1.1 Water container, large enough for the basket to be fully submerged when lying on its side (total volume of at least 3 l).

The container shall be filled with deionized water (5.1) to a depth of 100 mm.

7.1.2 Draining equipment, comprising a support which is adjusted so that the hanging cylindrical basket forms a $(30 \pm 3)^\circ$ angle with the horizontal (see Figure 1).

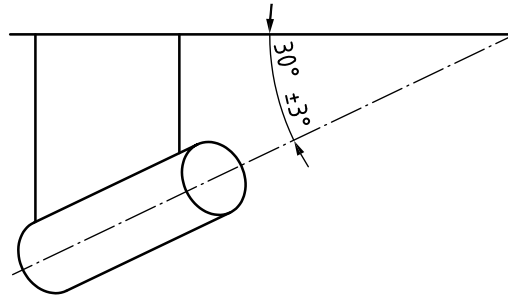

Figure 1 — Principle of drainage position

7.1.3 **Timer**, accurate to within $\pm 0,01$ s within a range of 60 s.

7.1.4 **Balance**, with an accuracy of 0,001 g.

7.1.5 **Cylindrical basket**, having the dimensions shown in Figure 2, constructed from any non-corroding steel gauge wire of $\varnothing 0,5$ mm to yield a total mass of $(3,0 \pm 0,1)$ g.

Dimensions in millimetres

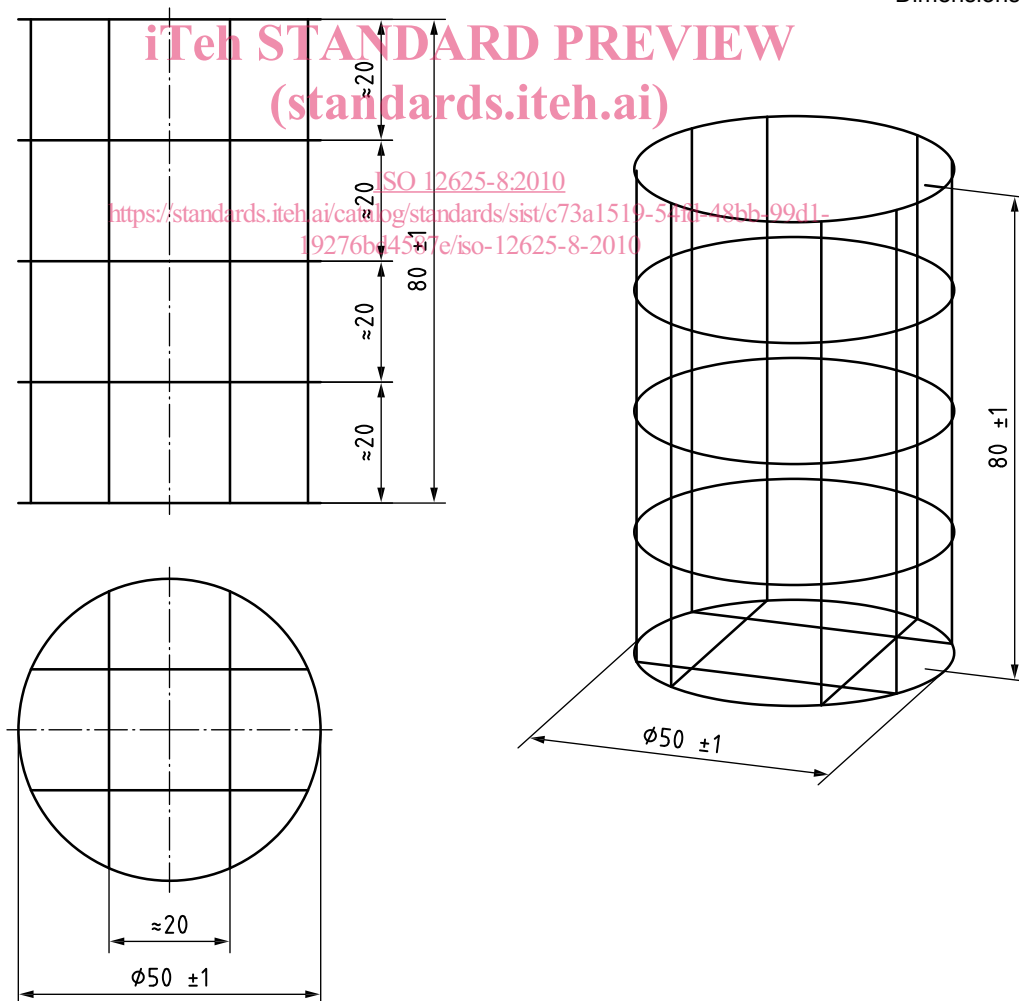

Figure 2 — Schematic drawing of the cylindrical basket

7.2 Procedure

7.2.1 Record the mass of the basket, m_b , in grams, to two decimal places.

7.2.2 Roll the test piece such that it matches the curvature of the cylindrical basket. Do not fold it. Place the weighted test piece in the cylindrical basket (7.1.5) so that it is loosely packed with its 76 mm edge parallel to the side of the basket.

7.2.3 Place the test piece in the cylindrical basket. Position the cylindrical basket at a distance of (25 ± 5) mm from the water surface maintained in a horizontal position.

7.2.4 Maintaining the horizontal orientation, release the cylindrical basket into the water and simultaneously start the timer (7.1.3).

7.2.5 Observe the wetting of the test piece to determine the moment that complete wetting occurs.

7.2.6 Stop the timer and record the time required for complete wetting of the test piece.

7.2.7 After the exact moment that the complete wetting of the sample is achieved (see 7.2.6), allow the cylindrical basket and test piece to remain submerged in the water for a further (30 ± 1) s.

NOTE One or two timers can be used to perform the measurements described in 7.2.6 and 7.2.7.

7.2.8 At the exact moment the 30 s immersion period of 7.2.7 is complete, remove the cylindrical basket from the water, keeping it in a horizontal position. Allow the timer to continue to run.

7.2.9 Hang the cylindrical basket containing the wetted test piece on the support (see 7.1.2) at the required 30° angle to the horizontal.

7.2.10 Allow the test piece to drain for a further (60 ± 1) s.

7.2.11 Immediately weigh the cylindrical basket and test piece. Record the mass, m_n , in grams, to two decimal places.

7.2.12 Repeat the procedure with each of the remaining four test pieces.

7.2.13 Change the water after each series of five tests.

8 Calculation and expression of results

Calculate the mean water-absorption time, and the standard deviation of the five replicate tests, in seconds.

Report the water-absorption time, in seconds, to the nearest 0,1 s.

Calculate the water-absorption capacity, W_a , in grams of water per gram of each test piece, from Equation (1):

$$W_a = \frac{m_n - m_o - m_b}{m_o} \quad (1)$$

where

m_n is the mass of the cylindrical basket and its contents after submersion and draining, in grams, to two decimal places;

m_o is the dry mass of each test piece, in grams, to two decimal places;

m_b is the mass of the cylindrical basket, in grams, to two decimal places.

Calculate the mean water-absorption capacity as the average of the five replicate tests, in grams of water per gram of the test piece.

9 Test report

The test report shall include the following information:

- a) a reference to this part of ISO 12625;
- b) the date and place of testing;
- c) conditioning atmosphere during the test, in accordance with ISO 187;
- d) all details necessary for the complete identification of the sample;
- e) dimensions of the test pieces (if different from those specified);
- f) mean water-absorption time and standard deviation;
- g) mean water-absorption capacity and standard deviation;
- h) any deviation from this part of ISO 12625 that may have affected the result.

10 Precision

10.1 General

In an interlaboratory study, 12 laboratories tested 10 tissue samples, in accordance with this part of ISO 12625. Reported data have been obtained with the manual method. The results are shown in Tables 1 and 2.

ISO 12625-8:2010

10.2 Reproducibility

The reproducibility is the variation between individual results, independently obtained by two operators, working in different laboratories, on the same material.

Table 1 — Results of an interlaboratory test

Sample	Mean water-absorption time	Standard deviation between laboratories	Reproducibility coefficient of variation	Reproducibility limit ^a
	s	s	%	s
A	3,2	0,2	6,3	0,6
B	25,6	3,5	13,7	9,7
C	2,6	0,2	7,7	0,6
D	7,9	0,4	5,1	1,1
E	3,8	0,3	7,9	0,8
F	4,7	0,5	10,6	1,4
Ga	10,1	1,2	11,9	3,3
Gb	6,8	0,7	10,3	1,9
H	4,8	0,6	12,5	1,7
I	3,8	0,3	7,9	0,8

^a Agreement expected with 95 % probability, $R = 1,96\sqrt{2} \times s$.