INTERNATIONAL STANDARD



938

INTERNATIONAL ORGANIZATION FOR STANDARDIZATION • МЕЖДУНАРОДНАЯ ОРГАНИЗАЦИЯ ПО СТАНДАРТИЗАЦИИ • ORGANISATION INTERNATIONALE DE NORMALISATION

Hand-operated stillage trucks — Principal dimensions

Chariots élévateurs à bras pour manutention de plates-formes — Dimensions principales

First edition — 1975-06-15

iTeh STANDARD PREVIEW
(standards.iteh.ai)

[ISO 938:1975](https://standards.iteh.ai/catalog/standards/sist/1bd8ed68-5add-45f4-b582-3b3d9c9ddb3c/iso-938-1975)

<https://standards.iteh.ai/catalog/standards/sist/1bd8ed68-5add-45f4-b582-3b3d9c9ddb3c/iso-938-1975>

UDC 629.111.31 : 621.869.8-181

Ref. No. ISO 938-1975 (E)

Descriptors : handling equipment, industrial trucks, lift trucks, dimensions.

FOREWORD

ISO (the International Organization for Standardization) is a worldwide federation of national standards institutes (ISO Member Bodies). The work of developing International Standards is carried out through ISO Technical Committees. Every Member Body interested in a subject for which a Technical Committee has been set up has the right to be represented on that Committee. International organizations, governmental and non-governmental, in liaison with ISO, also take part in the work.

Draft International Standards adopted by the Technical Committees are circulated to the Member Bodies for approval before their acceptance as International Standards by the ISO Council.

Prior to 1972, the results of the work of the Technical Committees were published as ISO Recommendations; these documents are now in the process of being transformed into International Standards. As part of this process, Technical Committee ISO/TC 110 has reviewed ISO Recommendation R 938 and found it technically suitable for transformation. International Standard ISO 938 therefore replaces ISO Recommendation R 938-1969 to which it is technically identical.

ISO Recommendation R 938 was approved by the Member Bodies of the following countries :

Australia	Greece	South Africa, Rep. of
Belgium	India	Sweden
Bulgaria	Iran	Switzerland
Chile	Ireland	Turkey
Czechoslovakia	Israel	United Kingdom
Egypt, Arab Rep. of	Italy	U.S.A.
France	Netherlands	Yugoslavia
Germany	Poland	

The Member Bodies of the following countries expressed disapproval of the Recommendation on technical grounds :

Japan
U.S.S.R.

No Member Body disapproved the transformation of ISO/R 938 into an International Standard.

Hand-operated stillage trucks – Principal dimensions

1 SCOPE AND FIELD OF APPLICATION

This International Standard specifies the dimensions of hand-operated stillage trucks, which are directly in relation to the corresponding dimensions of stillages.

NOTE – The dimensional specifications of stillages to be transported by hand-operated stillage trucks are fixed in ISO 1756, *Industrial trucks – Dimensions of stillages – Connection gauge.*

2 DIMENSIONS

2.1 Maximum height *A* of truck (with elevating frame lowered)

<i>A</i> max.	mm	in
	160 – 180 – 230 – 280	6 1/4 – 7 – 9 – 11

2.2 Maximum width *B* of truck

<i>B</i> max.	mm	in
	470 – 560 – 620 – 700	18 1/2 – 22 1/2 – 24 1/4 – 27 1/2

2.3 Basic length *C* of elevating frame

<i>C</i>	mm	in
	800 – 1 000 – 1 200 – 1 500 – 1 600	32 – 40 – 48 – 60 – 64

2.4 Lift *D*

	Lift		Tolerances	
	mm	in	mm	in
<i>D</i>	50	2	+ 1 – 5	0 – 1/4
			+ 1* – 10*	0* – 3/8*
	75	3	+ 1 – 5	0 – 1/4
	100	4	free** – 5	free** – 1/4

* Above 1 600 kg (3 500 lb) only.

** Upper deviation left free in order to permit the use of hydraulic lifting devices.

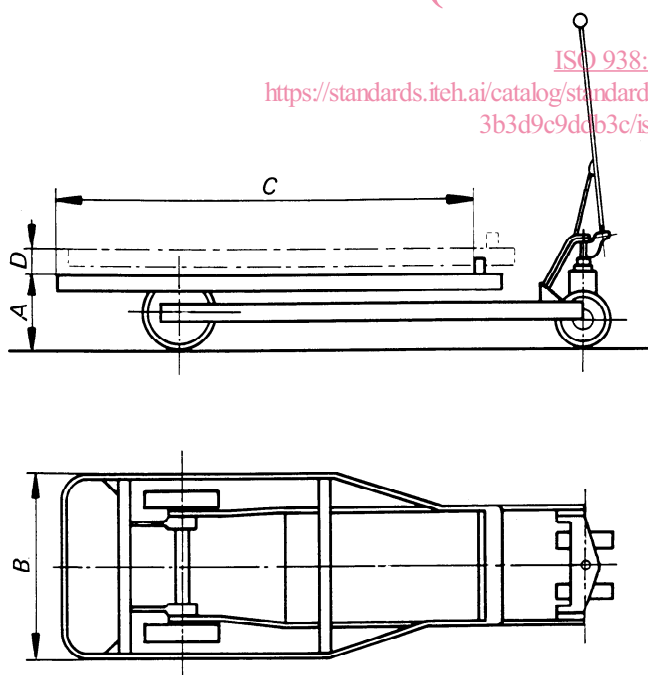

iTeh STANDARD PREVIEW
(standards.iteh.ai)

ISO 938:1975
<https://standards.iteh.ai/catalog/standards/sist/b18cd68-5add-4514-b582-3b3d9c9deb3c/iso-938-1975>

iTeh STANDARD PREVIEW

This page intentionally left blank
(standards.iteh.ai)

ISO 938:1975

<https://standards.iteh.ai/catalog/standards/sist/1bd8ed68-5add-45f4-b582-3b3d9c9ddb3c/iso-938-1975>