

ETSI TS 103 556 V1.1.1 (2018-06)



Speech and multimedia Transmission Quality (STQ); DTMF transmission over VoIP using RTP Telephony Events

ITEH STANDARDS PREVIEW
(standards.iteh.ai)
Full standard:
<https://standards.iteh.ai/catalog/standards/sist/5c103d-ee16-4b90-8295-c429d0d18178/etsi-ts-103-556-v1.1.1-2018-06>

Reference

DTS/STQ-262

Keywords

DTMF, VoIP

ETSI

650 Route des Lucioles
F-06921 Sophia Antipolis Cedex - FRANCE

Tel.: +33 4 92 94 42 00 Fax: +33 4 93 65 47 16

Siret N° 348 623 562 00017 - NAF 742 C
Association à but non lucratif enregistrée à la
Sous-Préfecture de Grasse (06) N° 7803/88

Important notice

The present document can be downloaded from:

<http://www.etsi.org/standards-search>

The present document may be made available in electronic versions and/or in print. The content of any electronic and/or print versions of the present document shall not be modified without the prior written authorization of ETSI. In case of any existing or perceived difference in contents between such versions and/or in print, the only prevailing document is the print of the Portable Document Format (PDF) version kept on a specific network drive within ETSI Secretariat.

Users of the present document should be aware that the document may be subject to revision or change of status.

Information on the current status of this and other ETSI documents is available at

<https://portal.etsi.org/TB/ETSIDeliverableStatus.aspx>

If you find errors in the present document, please send your comment to one of the following services:

<https://portal.etsi.org/People/CommiteeSupportStaff.aspx>

Copyright Notification

No part may be reproduced or utilized in any form or by any means, electronic or mechanical, including photocopying and microfilm except as authorized by written permission of ETSI.

The content of the PDF version shall not be modified without the written authorization of ETSI.

The copyright and the foregoing restriction extend to reproduction in all media.

© ETSI 2018.

All rights reserved.

DECT™, **PLUGTESTS™**, **UMTS™** and the ETSI logo are trademarks of ETSI registered for the benefit of its Members.

3GPP™ and **LTE™** are trademarks of ETSI registered for the benefit of its Members and of the 3GPP Organizational Partners.

oneM2M logo is protected for the benefit of its Members.

GSM® and the GSM logo are trademarks registered and owned by the GSM Association.

Contents

Intellectual Property Rights	4
Foreword.....	4
Modal verbs terminology.....	4
1 Scope	5
2 References	5
2.1 Normative references	5
2.2 Informative references.....	5
3 Definitions and abbreviations.....	6
3.1 Definitions.....	6
3.2 Abbreviations	6
4 Telephone Events for the transmission of DTMF Signals	6
4.1 Introduction	6
4.2 Signal input requirements for DTMF receivers in media gateways and SBC scenarios	7
4.3 Signal output requirements of DTMF signals for sender in media gateways and SBC scenarios.....	7
4.4 Telephony Event Procedures.....	7
4.4.1 Introduction.....	7
4.4.2 Sending procedures.....	7
4.4.3 Receiving procedures.....	8
History	9

iTeh STANDARD PREVIEW
 (standards.iteh.ai)
 Full standard:
<https://standards.iteh.ai/catalog/standards/sist/a5e5d93d-ec16-4b90-8295-c429d0d18178/etsi-ts-103-556-v1.1.1-2018-06>

Intellectual Property Rights

Essential patents

IPRs essential or potentially essential to normative deliverables may have been declared to ETSI. The information pertaining to these essential IPRs, if any, is publicly available for **ETSI members and non-members**, and can be found in ETSI SR 000 314: "*Intellectual Property Rights (IPRs); Essential, or potentially Essential, IPRs notified to ETSI in respect of ETSI standards*", which is available from the ETSI Secretariat. Latest updates are available on the ETSI Web server (<https://ipr.etsi.org/>).

Pursuant to the ETSI IPR Policy, no investigation, including IPR searches, has been carried out by ETSI. No guarantee can be given as to the existence of other IPRs not referenced in ETSI SR 000 314 (or the updates on the ETSI Web server) which are, or may be, or may become, essential to the present document.

Trademarks

The present document may include trademarks and/or tradenames which are asserted and/or registered by their owners. ETSI claims no ownership of these except for any which are indicated as being the property of ETSI, and conveys no right to use or reproduce any trademark and/or tradename. Mention of those trademarks in the present document does not constitute an endorsement by ETSI of products, services or organizations associated with those trademarks.

Foreword

This Technical Specification (TS) has been produced by ETSI Technical Committee Speech and multimedia Transmission Quality (STQ).

Modal verbs terminology

In the present document "**shall**", "**shall not**", "**should**", "**should not**", "**may**", "**need not**", "**will**", "**will not**", "**can**" and "**cannot**" are to be interpreted as described in clause 3.2 of the [ETSI Drafting Rules](#) (Verbal forms for the expression of provisions).

"**must**" and "**must not**" are **NOT** allowed in ETSI deliverables except when used in direct citation.

1 Scope

The present document provides the level of detail that will enable manufacturers of telecommunications equipment incorporating Telephony Events described in IETF RFC 4733 [1] for the transport of DTMF signalling to design the equipment. The present document specifies the signal receiver and transmitter requirements of DTMF signals.

2 References

2.1 Normative references

References are either specific (identified by date of publication and/or edition number or version number) or non-specific. For specific references, only the cited version applies. For non-specific references, the latest version of the referenced document (including any amendments) applies.

Referenced documents which are not found to be publicly available in the expected location might be found at <https://docbox.etsi.org/Reference/>.

NOTE: While any hyperlinks included in this clause were valid at the time of publication, ETSI cannot guarantee their long term validity.

The following referenced documents are necessary for the application of the present document.

- [1] IETF RFC 4733: "RTP Payload for DTMF Digits, Telephony Tones, and Telephony Signals".
- [2] ETSI ES 201 235-1: "Specification of Dual Tone Multi-Frequency (DTMF) Transmitters and Receivers; Part 1: General".

NOTE: Available at http://www.etsi.org/deliver/etsi_es/201200_201299/20123501/01.01.01_60/es_20123501v010101p.pdf.

- [3] ETSI ES 201 235-2: "Access and Terminals (AT); Specification of Dual-Tone Multi-Frequency (DTMF) Transmitters and Receivers; Part 2: Transmitters".

NOTE: Available at http://www.etsi.org/deliver/etsi_es/201200_201299/20123502/01.02.01_60/es_20123502v010201p.pdf.

- [4] ETSI ES 201 235-3: "Access and Terminals (AT); Specification of Dual-Tone Multi-Frequency (DTMF) Transmitters and Receivers; Part 3: Receivers".

NOTE: Available at http://www.etsi.org/deliver/etsi_es/201200_201299/20123503/01.03.01_60/es_20123503v010301p.pdf.

2.2 Informative references

References are either specific (identified by date of publication and/or edition number or version number) or non-specific. For specific references, only the cited version applies. For non-specific references, the latest version of the referenced document (including any amendments) applies.

NOTE: While any hyperlinks included in this clause were valid at the time of publication, ETSI cannot guarantee their long term validity.

The following referenced documents are not necessary for the application of the present document but they assist the user with regard to a particular subject area.

- [i.1] Recommendation ITU-T G.729: "Coding of speech at 8 kbit/s using conjugate-structure algebraic-code-excited linear prediction (CS-ACELP)".
- [i.2] Recommendation ITU-T G.711: "Pulse code modulation (PCM) of voice frequencies".

3 Definitions and abbreviations

3.1 Definitions

For the purposes of the present document, the terms and definitions apply:

telephony events: transmission method to carry Dual-Tone Multi Frequency (DTMF) signalling and other tone signals in RTP packets described in IETF RFC 4733 [1]

3.2 Abbreviations

For the purposes of the present document, the following abbreviations apply:

DTMF	Dual-Tone Multi Frequency
MGW	Media GateWay
PSTN	Public Switched Telephone Network
RTP	Real-time Transport Protocol
SBC	Session Border Controller
SDP	Session Description Protocol

4 Telephone Events for the transmission of DTMF Signals

4.1 Introduction

The telephone events are suitable for transmission of DTMF Signals between media gateways and for end-to-end scenarios. In the gateway scenario, an Internet telephony media gateway connecting to a packet voice network, the PSTN recreates the DTMF tones or other telephony events and injects them into the PSTN. The RTP Payload for DTMF Digits, Telephony Tones, and Telephony Signals are defined in IETF RFC 4733 [1]. The present document specifies the signal receiver and transmitter requirements of DTMF signals. The Signal condition requirements are based on the ETSI ES 201 235-1 [2], ETSI ES 201 235-2 [3] and ETSI ES 201 235-3 [4].

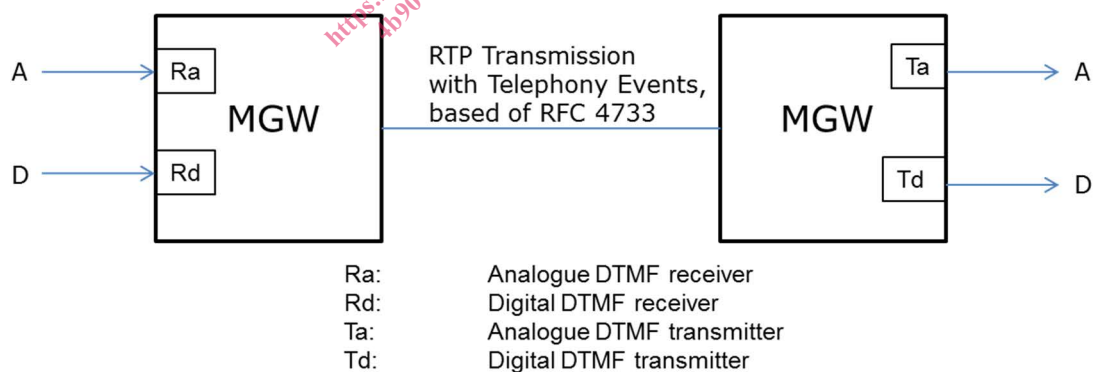

Figure 1: Reference configuration scenario between two MGW

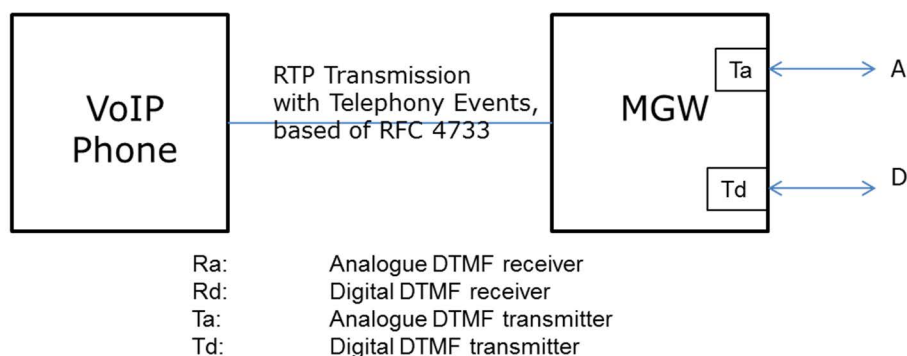

Figure 2: Reference configuration scenario between MGW and VoIP Phone (Fixed wired or mobile)

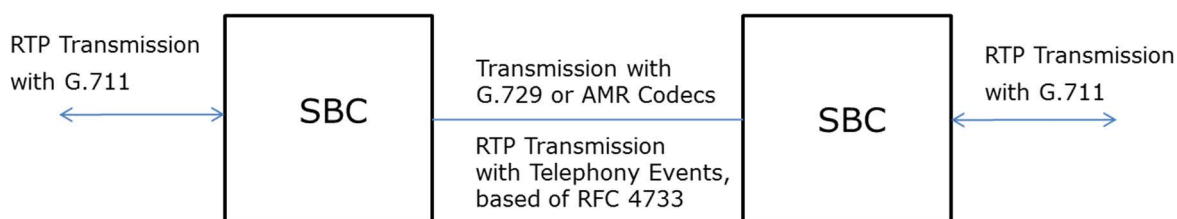

Figure 3: Reference configuration scenario between two SBC (Fixed wired or mobile)

4.2 Signal input requirements for DTMF receivers in media gateways and SBC scenarios

The receiver shall comply with ETSI ES 201 235-3 [4].

4.3 Signal output requirements of DTMF signals for sender in media gateways and SBC scenarios

The transmitter shall comply with ETSI ES 201 235-2 [3].

4.4 Telephony Event Procedures

4.4.1 Introduction

This clause defines the procedures associated with the tone telephony event procedures described in IETF RFC 4733 [1].

In the gateway scenario, a telephony media gateway connecting to a packet voice network creates telephony events. In the end system scenario, the DTMF events are consumed by the receiving entity itself.

4.4.2 Sending procedures

The telephone-event payload shall not be inherently redundant with the RTP packets (DTMF in audio), as described in section 4.4.1 of IETF RFC 4733 [1]. The maximal DTMF audio Signal leakage shall be lower than 5 ms.

If in the media gateway scenario RTP events are not offered in SDP, DTMF shall be transmitted in Audio transparently to the receiving media gateway.

4.4.3 Receiving procedures

Receiving implementations play out the tones as received, typically with a playout delay to allow for lost packets. In the case when telephony events and RTP packets received are inherently redundant, only DTMF from the telephony events should be played out. The maximal DTMF Signal leakage shall be lower than 15 ms.

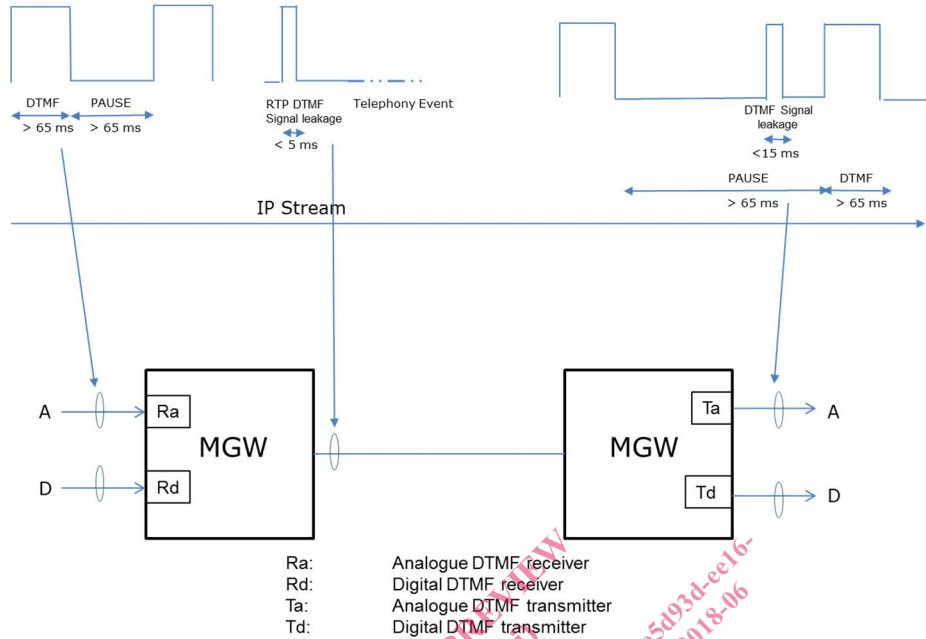

Figure 4: Reference configuration scenario between two MGW with signal samples