



Designation: C 739 – 05b^{ε1}

Standard Specification for Cellulosic Fiber Loose-Fill Thermal Insulation¹

This standard is issued under the fixed designation C 739; the number immediately following the designation indicates the year of original adoption or, in the case of revision, the year of last revision. A number in parentheses indicates the year of last reapproval. A superscript epsilon (ϵ) indicates an editorial change since the last revision or reapproval.

This standard has been approved for use by agencies of the Department of Defense.

^{ε1} NOTE—Table 3 was editorially corrected in May 2007.

1. Scope

1.1 This specification covers the composition and physical requirements of chemically treated, recycled cellulosic fiber loose-fill type thermal insulation for use in attics or enclosed spaces in housing, and other framed buildings within the ambient temperature range from -45 to 90°C (-49 to 194°F) by pneumatic or pouring application. While products that comply with this specification are used in various constructions, they are adaptable primarily, but not exclusively, to wood joist, rafters, and stud construction.

1.2 The values stated in SI units are to be regarded as the standard. The values in parentheses are provided for information only.

1.3 *This standard does not purport to address all of the safety concerns, if any, associated with its use. It is the responsibility of the user of this standard to establish appropriate safety and health practices and determine the applicability of regulatory limitations prior to use.*

2. Referenced Documents

2.1 *ASTM Standards:*²

- B 152** Specification for Copper Sheet, Strip, Plate, and Rolled Bar
- C 168** Terminology Relating to Thermal Insulation
- C 177** Test Method for Steady-State Heat Flux Measurements and Thermal Transmission Properties by Means of the Guarded-Hot-Plate Apparatus
- C 518** Test Method for Steady-State Heat Flux Measurements and Thermal Transmission Properties by Means of

¹ This specification is under the jurisdiction of ASTM Committee C16 on Thermal Insulation and is the direct responsibility of Subcommittee C16.23 on Blanket and Loose Fill Insulation.

Current edition approved Nov. 15, 2005. Published December 2005. Originally approved 1973. Last previous edition approved 2005 C 739 – 05a.

² For referenced ASTM standards, visit the ASTM website, www.astm.org, or contact ASTM Customer Service at service@astm.org. For *Annual Book of ASTM Standards* volume information, refer to the standard's Document Summary page on the ASTM website.

the Heat Flow Meter Apparatus

- C 687** Practice for Determination of Thermal Resistance of Loose-Fill Building Insulation
- C 1045** Practice for Calculating Thermal Transmission Properties from Steady-State Conditions
- C 1114** Test Method for Steady-State Thermal Transmission Properties by Means of the Thin-Heater Apparatus
- C 1374** Test Method for Determination of Installed Thickness of Pneumatically Applied Loose-Fill Building Insulation
- C 1363** Test Method for Thermal Performance of Building Materials and Envelope Assemblies by Means of a Hot Box Apparatus
- C 1485** Test Method for Critical Radiant Flux of Exposed Attic Floor Insulation Using an Electric Radiant Heat Energy Source
- E 970** Test Method for Critical Radiant Flux of Exposed Attic Floor Insulation Using a Radiant Heat Energy Source

3. Terminology

3.1 *Definitions*—For definitions of terms used in this specification, see Terminology **C 168**.

3.2 *Definitions of Terms Specific to This Standard:*

- 3.2.1 *attic*—an enclosed space between the roof and ceiling of the occupied part of a building.
- 3.2.2 *critical radiant flux*—the level of incident radiant heat energy on the attic floor insulation system at the most distant flame-out point (W/cm^2 ($\text{Btu}/\text{ft}^2 \cdot \text{s}$)).

4. Materials and Manufacture

4.1 The basic material shall be recycled cellulosic fiber made from selected paper, paperboard stock, or ground wood stock, excluding contaminated materials, which may reasonably be expected to be retained in the finished product. Suitable chemicals are introduced to provide properties such as flame resistance, processing, and handling characteristics.

4.2 The basic material may be processed into a form suitable for installation by pneumatic or pouring methods.

5. Physical and Chemical Properties

5.1 *Design Density*—The design density shall be determined in accordance with Section 8. Report all units in kg/m³ (lb/ft³).

5.1.1 Design density is not a basis for acceptance or rejection.

5.2 *Corrosiveness*—The loose-fill insulation material shall be tested for corrosiveness as specified in Section 9. The composition of the insulation material shall be such that after testing, no perforation of the 3-mil (76- μ m) metal specimens shall be evident when the specimens are observed over a 40-W appliance light bulb. Notches extending into the coupon 3 mm or less from any edge shall be ignored.

5.3 *Critical Radiant Flux*—When tested in accordance with Section 10, the critical radiant flux shall be equal to greater than 0.12 W/cm² (0.11 Btu/ft²·s). All values shall be reported to two significant digits.

5.4 *Fungi Resistance*—The loose-fill insulation material shall be tested and shall pass fungi resistance as specified in Section 11. If the growth on two or more of the replicate test items is greater than that on the comparative item, the test item shall be considered to fail.

NOTE 1—If the manufacturing claims the insulation kills or controls insects or rodents, or both, the product must be registered as a pesticide under the Federal Insecticide, Fungicide and Rodenticide Act, as amended, and must also be registered in accordance with state pesticide statutes.

5.5 *Moisture Vapor Sorption*—Moisture gain in the insulation shall be no more than 15 % by weight when tested in accordance with Section 12.

5.6 *Odor Emission*—Any sample producing a detectable odor that is classified as objectionable and strong or very strong by more than two panel members shall be considered to have failed the test when tested in accordance with Section 13.

5.7 *Smoldering Combustion*—When tested in accordance with the smoldering combustion test method in Section 14, the insulation shall show no evidence of flaming and a weight loss no greater than 15 %.

5.8 *Thermal Resistance*—The standard thermal resistance values normally recommended for open application are: 2.3, 3.4, 3.9, 5.3, 6.7, and 8.6 (13, 19, 22, 30, 38 and 49) and are expressed in K·m²/W (°F·h·ft²/Btu). The thermal resistance *R* for the average of any (four) randomly selected specimens shall not be more than 5 % below the listed *R* value when tested in accordance with Section 15. *R* values other than those listed shall be as agreed upon between the supplier and the purchaser.

6. Workmanship, Finish, and Appearance

6.1 The product shall be free of extraneous foreign materials such as metals and glass that will adversely affect the performance in service.

TEST METHODS

7. Summary

7.1 The following tests shall be conducted on loose-fill cellulosic insulation at the measured design density: moisture vapor sorption, smoldering combustion, and thermal resistance.

NOTE 2—The importance of an insulation's product to maintain its fire retardant characteristics is recognized. A task group in ASTM C16.31 is currently studying methods to ascertain if there is a long-term deterioration of fire performance characteristics of cellulose insulation. Should the need for a permanency test be determined by this task group and a test method be developed and finalized, it will become a part of this specification.

8. Design Density

8.1 *Scope*—This test method provides a basis for calculating the product coverage values and for conducting physical property tests requiring the use of design density for sample preparation.

8.2 *Significance and Use*—The design density is the approximate density expected after long-term attic application.

8.3 *Apparatus and Materials:*

8.3.1 *Insulation Specimen Container*—A beaker having a flat bottom and an inside diameter of 15.0 ± 1 cm (5.9 ± 0.39 in.), straight sides. The height of the beaker shall be such that the distance between the bottom of the cyclone and the top edge of the beaker is 8.50 ± 1.0 cm (3.35 ± 0.39 in.).

8.3.2 *Flat Rigid Disk*, having a total weight of 75 ± 5 g (2.65 ± 0.18 oz) and of a suitable diameter to fit loosely into the specimen container. Weight may be added to the center of the disk to bring the total weight to the required 75 ± 5 g.

8.3.3 *Balance*, having a 2-kg (4.41-lb) capacity accurate to ± 0.2 g (± 0.007 oz).

8.3.4 *Blower Apparatus*, having two blower units (supply and overflow) meeting the following specifications:

8.3.4.1 Each blower apparatus shall be capable of blowing an average of 272.2 kg (600 lb) of insulation per hour.

8.3.4.2 Each blower apparatus shall have a nominal air flow velocity of 0.38 m/s (75 ft/min).

8.3.4.3 Each blower apparatus shall have a nominal motor speed of 16 450 r/min at 115 V (a-c).

8.3.5 *Shaker Unit*, having a capability of shaking 4.5 kg (10 lb) of weight with a vertical motion of 0.5 g rms acceleration at an approximate frequency of 9 Hz and displacement of approximately 1.17 ± 0.08 cm (¹⁵/₃₂ ± ¹/₃₂ in.).

8.3.6 *Fill Chamber*, having inside dimensions of 45.7 cm (18 in.) high by 38.1 cm (15 in.) wide by 38.1 cm (15 in.) deep, with covered openings that will allow a radiant panel tray to be slid through the chamber (see Fig. 1).

8.3.7 *Cyclone Receiver*—See Fig. 2.

8.3.8 *Hose*—Various lengths of nominal 5.08-cm (2-in.) diameter hose (see Fig. 1):

8.3.8.1 *Supply Source Hose*, 274.3 ± 5.1 cm (108 ± 2 in.).

8.3.8.2 *Cyclone Receiver Hose*, 182.9 ± 5.1 cm (72 ± 2 in.).

8.3.8.3 *Fill Chamber Exit Hose*, 91.4 ± 5.1 cm (36 ± 2 in.).

8.3.8.4 *Overflow Exhaust Hose*, length as needed.

8.3.9 *Blower Controls*, having capability of operating the two blowers at 40 V rms and 12 A.

8.3.10 *Insulation Holding Container*, capable of holding four times the amount of insulation required to fill the specimen container.

8.3.11 *Garden Rake*, with steel teeth.

8.4 *Conditioning:*

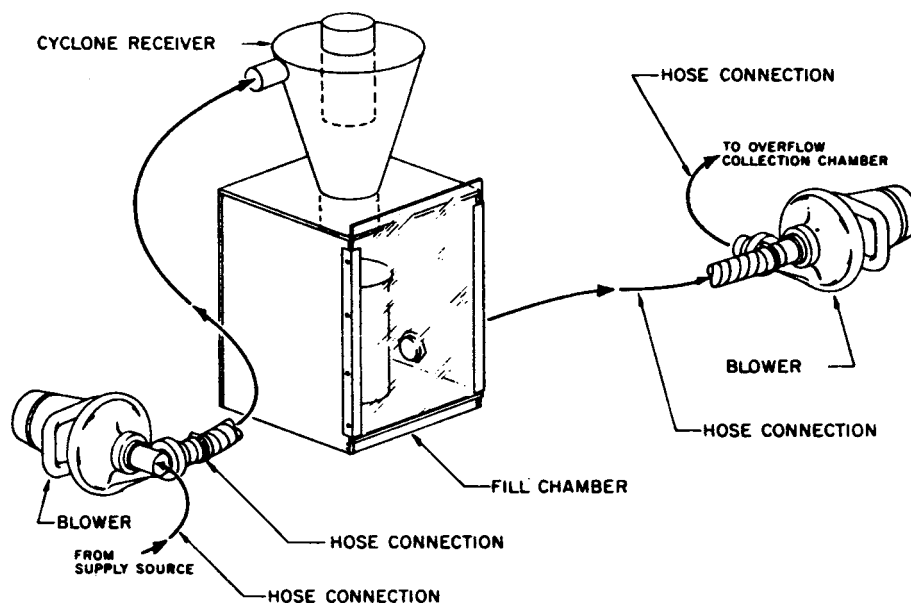

FIG. 1 Partial Insulation Preparation Apparatus

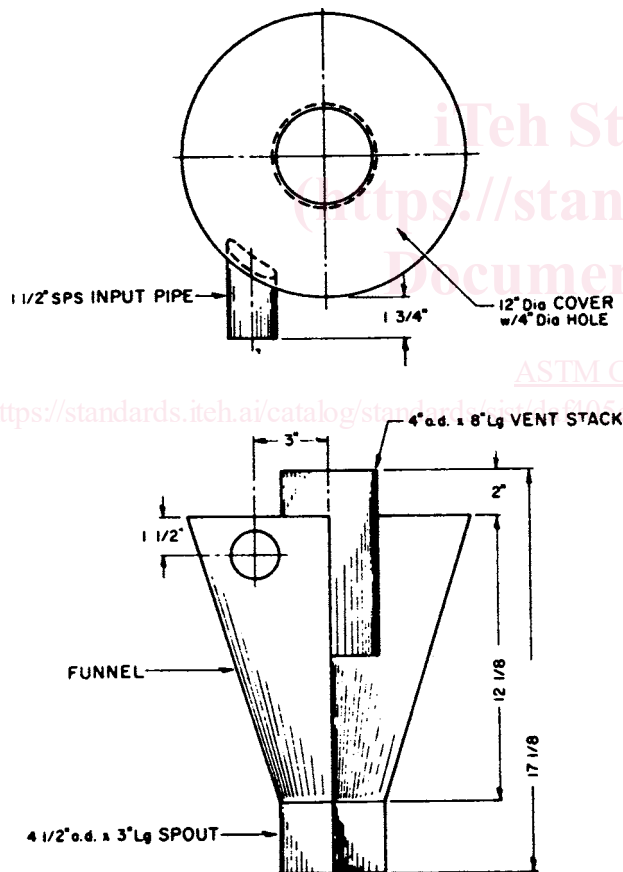

FIG. 2 Cyclone Receiver Weldment

8.4.1 Condition specimens to equilibrium at $21 \pm 2.0^\circ\text{C}$ ($69.8 \pm 3.6^\circ\text{F}$) and $50 \pm 5\%$ relative humidity in an open top mesh bottom container not exceeding 10.16 cm (4 in.) in depth and position in such a way to allow free movement of air on

exposed sides. A change in net weight of the specimen that is less than 1% in two consecutive weighings with 24 h between each weighing constitutes equilibrium.

8.4.2 If ambient laboratory conditions are different from the conditioning requirements specified in 8.4.1, begin testing the specimen for design density within 10 min after it has been removed from the conditioned area.

8.5 Procedure for Pneumatic Applications:

8.5.1 Conduct the test in an area conditioned in accordance with 8.4.1.

8.5.2 Blow the material through a commercial blower using 30.48 m (100 ft.) of 5.08 cm (2 in.) hose into a sample receiver while holding the hose horizontally at a height of four feet.

8.5.3 Set up the apparatus as shown in Fig. 1. Connect one end of the supply source hose to the intake of the supply blower. Use the other end of the supply source hose to pick up insulation from the holding container. Connect one end of the cyclone receiver hose to the outlet of the supply blower and the other end to the fill chamber. Place the fill chamber on a flat and level surface. Connect one end of the variable length overflow exhaust hose to the outlet of the overflow blower. Conveniently place the other end to reduce insulation dust in the test area.

8.5.4 Weigh the empty insulation specimen container and record its weight.

8.5.5 Place the empty insulation specimen container in the fill chamber, centered under the cyclone receiver, and close the front cover.

8.5.6 Adjust the blower control(s) so that the supply and overflow blowers will operate at a no-load voltage of 40 V rms.

8.5.7 Simultaneously turn on the blowers and proceed to fill the insulation specimen container by picking up material from the holding container using the supply source hose.

8.5.8 The container may fill unevenly, that is, a void may tend to form off center in the container. If this occurs, stop the

blowing process and rotate the container. If, for any reason, the filling process is interrupted for more than 1 min or for more than the time allowed to rotate the container once, begin the process again.

8.5.9 Gently remove the excess material using a straight edge to leave a uniform surface on the insulation flush with the top of the container.

8.5.10 Weigh the filled and leveled container and record the weight. Take care not to bump or jar the container so not to introduce any extraneous settling of the insulation.

8.5.11 Cover the container to prevent spilling and secure the container to the shaker. Operate the shaker for a period of 5 min \pm 15 s.

8.5.12 Remove the container from the shaker and uncover, taking care not to bump or jar it. Lower the disk very slowly into the container until it starts to contact the insulation. At this point, release the disk and allow it to settle onto the insulation under its own weight.

8.5.13 Measure the volume of the space occupied by the insulation using the bottom edge of the disk as the upper datum point. If the disk is not level, measure the high and low points of the bottom of the disk and average the readings and use this as the height measurement in calculating the volume (V_s). Calculate the design density using the insulation volume and insulation mass (W).

8.5.14 Repeat 8.5.1-8.5.13 using another specimen of the insulation until four densities are obtained for a given material. Then average these figures to determine the design density.

8.6 Procedure for Pouring Applications:

8.6.1 Pour loose-fill insulation into a simulated attic space until full. The attic space shall be formed by two nominal 2 by 6 by 8-ft long joists placed 40.6 cm (16 in.) on center with 1.27-cm (1/2-in.) plywood nailed to the ends and bottom. Fluff the material with a garden rake, applying a series of small amplitude strokes while moving the rake slowly along the joist. Repeat the fluffing process six times.

8.6.2 Weigh the empty insulation specimen container and record its mass.

8.6.3 Using a shovel, remove the insulation from the simulated attic space and place it into the specimen container until the container just begins to overflow.

8.6.4 Follow the procedure specified in 8.5.9-8.5.13.

8.6.5 Repeat 8.6.2-8.6.4 using another specimen of the insulation until four densities are obtained for a given material. Then average these values to determine the design density.

8.7 Procedure for Pouring and Pneumatic Applications—If the insulation is intended for both pouring and pneumatic applications, or if it is uncertain whether the insulation will be poured or installed pneumatically, test the insulation for design density in accordance with 8.4, 8.5, and 8.6 for each of the applications.

8.8 Calculations—Calculate the design density, in kg/m³ (lb/ft³), of each specimen using Eq 1:

$$\text{Design density} = W/V_s \quad (1)$$

where:

W = combined mass of the container and insulation minus the mass of the container, g, and

V_s = volume of insulation in container after shaking, L.

8.9 Precision and Bias—

8.9.1 Precision³—The precision of this test method was determined from a report published in the Federal Register, March 8, 1979. Seven laboratories participated in an interlaboratory test program designed to determine the repeatability and reproducibility of the proposed CPSC settled density test for cellulosic loose fill insulation. Each laboratory conducted the settled density test on seven different cellulosic loose fill insulation materials. Four replicate tests were run on each sample. Table 1 shows an estimate of precision based on the interlaboratory tests. The results for two materials, cotton and groundwood, are not included.

8.9.2 Bias—No information can be presented on the bias of this test method because no materials having an accepted reference value are available.

9. Corrosiveness

9.1 Scope—This test method covers the determination of the corrosiveness of cellulosic insulation. The cellulosic insulation shall be tested for corrosiveness using the measured design density, as determined in Section 8. The pass/fail criteria is given in 5.2.

9.2 Significance and Use—This test method provides a basis for estimating the corrosiveness of cellulosic insulation in contact with steel, copper, and aluminum test materials. The test method represents one set of exposure conditions designed to accelerate possible corrosive effects, and may not simulate exposure conditions experienced in actual field applications.

9.3 Apparatus and Materials:

9.3.1 Humidity Chamber (Test Method A), air-circulating, capable of maintaining a temperature of 48.9 \pm 1.7°C (120 \pm 3°F) and 97 \pm 1.5 % relative humidity throughout the active portion of the chamber.

9.3.2 Oven (Test Method B), air circulating, capable of maintaining a temperature of 48.9 \pm 1.7°C (120 \pm 3°F) throughout the active portion of the chamber.

9.3.3 Crystallizing Dishes, six, glass, 90 mm (3.54 in.) in diameter by 50 mm (1.97 in.) in height.

9.3.4 Containers, six, glass, polyethylene or polypropylene, with screw cap or friction top lid capable of sealing, 127 mm (5 in.) in nominal diameter and 76 mm (3 in.) in nominal height.

9.3.5 Gloves, clean and in good condition.

9.3.6 Chemicals—Reagent-grade chemicals shall be used in all tests. Unless otherwise indicated, it is intended that all reagents shall conform to the specifications of the Committee on Analytical Reagents of the American Chemical Society, where such specifications are available.⁴

9.3.7 Water, sterile and either distilled or deionized.

³ Supporting data have been filed at ASTM International Headquarters and may be obtained by requesting Research Report RR:C16-1010.

⁴ Reagent Chemicals, American Chemical Society Specifications, American Chemical Society, Washington, DC. For suggestions on the testing of reagents not listed by the American Chemical Society, see *Analar Standards for Laboratory Chemicals*, BDH Ltd., Poole, Dorset, U.K., and the *United States Pharmacopeia and National Formulary*, U.S. Pharmacopeial Convention, Inc. (USPC), Rockville, MD.

TABLE 1 Precision for Cellulose Insulation

5 spec., 7 labs, 4 replicates	Avg. (PCF)	Repeatability/ % Mean	Reproducibility/ % Mean
Sample N	3.06	$r = 0.211020/6.90 \%$	$R = 0.847863/27.74 \%$
Sample K	3.20	$r = 0.261434/8.26 \%$	$R = 0.741396/23.15 \%$
Sample L	3.29	$r = 0.203637/6.18 \%$	$R = 0.901550/27.37 \%$
Sample Q	3.50	$r = 0.288375/8.25 \%$	$R = 0.429642/12.29 \%$
Sample M	3.88	$r = 0.272431/7.02 \%$	$R = 1.053352/27.14 \%$

9.3.8 Forceps.

9.3.9 Test Coupons:

9.3.9.1 Two, 3003 Bare Aluminum alloy, zero temper.

9.3.9.2 Two, Specification **B 152**, Type ETP, Cabra No. 110 soft copper.

9.3.9.3 Two, low-carbon, commercial quality, cold-rolled, less than 0.30 % carbon, shim steel.

9.3.9.4 Each coupon shall be 50.8 by 50.8 by 0.076-mm (2 by 2 by 0.003-in.) thick, free of tears, punctures, or crimps. Six coupons shall be used for one test of the insulation.

9.4 *Sampling*—Samples of cellulose insulation used for testing shall be blown, combed, or otherwise mixed to reasonably ensure homogeneity of the sample.

9.5 Procedure:

9.5.1 *Precleaning Metal Coupons:*

9.5.1.1 During fabrication, cleaning, or testing, never touch the metal coupons by ungloved hands.

9.5.1.2 Handle cleaned coupons with only clean forceps.

9.5.1.3 In order to avoid exposing laboratory personnel to toxic fumes, perform all cleaning in a fume hood.

9.5.1.4 Clean the coupons by vapor degreasing with 1-1-1 trichloroethane for 10 min. Following vapor degreasing, subject the coupons to caustic or detergent washing, or both, as appropriate. Following caustic or detergent washing, rinse the coupons in flowing water to remove residues. Inspect each coupon for a water-break free surface. (A water-break is a break, separation, beading, or retraction of the water film as the coupon is held vertically after wetting.) As the coupons are cleaned, the water film should become gradually thinner at the top and heavier at the bottom. Hot-air dry the coupons at 105°C (221°F).

9.5.2 *Preparation of Test Samples:*

9.5.2.1 Determine the design density of the sample in accordance with Section 8.

9.5.2.2 For each metal coupon, subdivide a 20-g (0.7-oz) sample of insulation into two 10-g (0.35-oz) portions. Determine the quantity of sterile and either distilled or deionized water to be used for each 10-g (0.35-oz) portion in accordance with Eq 2:

$$\frac{2.9}{d} \times 75 \text{ mL} \quad (2)$$

where d = design density, lb/ft³.

9.5.2.3 Presaturate each 10-g (0.35-oz) portion with the determined amount of water. Place one presaturated 10-g (0.35-oz) portion into a crystallizing dish, tamp level using the bottom of a clean suitably sized glass beaker. Place a metal coupon onto the presaturated insulation portion and center it in a horizontal plane. Place the other presaturated 10-g (0.35-oz) portion into the crystallizing dish on the metal coupon and

tamp the composite specimen (metal coupon and saturated insulation in the crystallizing dish) to ensure an even distribution of this material and to ensure good contact of the insulation with the metal. Exercise care in preparing the composite specimens to eliminate air pockets from forming next to the metal coupons.

9.5.2.4 Do not cover the crystallizing dish. Care should be taken to avoid evaporation from the composite during preparation or until it is placed on the testing chamber.

9.5.3 *Sample Test Cycle*—Use either a humidity chamber (Method A) or an oven (Method B) to provide the required temperature and relative humidity exposure.

9.5.3.1 *Test Method A*—Test Method A is given to be consistent with federal standards and Test Method B is given as an alternative since the 97 ± 1.5 % relative humidity is an alternative requirement.

(1) Precondition the humidity chamber to 48.9 ± 1.7°C (120 ± 3°F) and 97 ± 1.5 % relative humidity.

(2) Place all six composite samples in the humidity chamber. Keep the samples in the humidity chamber 336 ± 4 h. During the test cycle, periodically monitor the temperature and humidity.

(3) During the test cycle, do not open the humidity chamber unless it can be determined that such openings do not adversely affect the test cycle.

(4) If drippings of condensate occurs within the humidity chamber, position guards over the samples to prevent the condensate from falling onto the samples.

9.5.3.2 *Test Method B:*

(1) Precondition the oven to 48.9 ± 1.7°C (120 ± 3°F).

(2) Place the crystallizing dishes containing the composite sample in separate 127-mm (5-in.) diameter containers.

(3) Add 70 mL of sterile and either distilled or deionized water solution plus 25 g (0.88 oz) of potassium sulfate to the annular space between the crystallizing dish and the container. Use care not to add any of the solution to the composite sample. If any of the solution is inadvertently added to the composite sample, prepare a new composite.

(4) Loosely place the covers on the containers and preheat the containers 1 h in the oven at 48.9 ± 1.7°C (120 ± 3°F). After preheating, seal the containers by tightening the covers. Keep the containers in the oven 336 ± 4 h. During the test cycle, periodically monitor the temperature.

(5) During the test cycle, do not open the oven unless it can be determined that opening does not adversely affect the test cycle.

9.5.4 *Post-Test Cleaning of the Metal Coupons*—After completing the test cycle, disassemble the composite specimens. Thoroughly wash the metal coupons under running water and lightly brush them using a soft nylon bristle brush or equivalent to remove loose corrosion products. Remove the remaining corrosion products from the metal coupons by cleaning them as follows in a fume hood:

9.5.4.1 *Technique No. 1—Electrolytic Cleaning* (for copper, steel, and aluminum coupons). Electrolyze the coupons by making a solution containing 28 mL of sulfuric acid (sp gr 1.84), 2 mL of organic inhibitor (for example, about 0.5 g/L of such inhibitors as diorthotolyl thiourea, quinoline ethiodide, or

betanaphthol quinoline) and 970 mL water. Maintain the solution at 75°C (167°F). Use carbon or lead for the anode and one metal coupon for the cathode. Electrolyze for 3 min at a current density of 20 A/cm². See **Note 3** and **Note 4**.

NOTE 3—If using lead anodes, lead may deposit on the coupon. If the coupon is resistant to nitric acid, remove the lead by a flash dip in a solution of equal parts nitric acid and water.

NOTE 4—To avoid injury when mixing acid and water, for electrolytic cleaning gradually pour the acid into the water with continuous stirring, and provide cooling if necessary.

9.5.4.2 Technique No. 2—Copper (This technique or Technique No. 1 may be used for postcleaning only the tested copper coupons.) Make a solution containing 500 mL of hydrochloric acid (sp gr 1.19), 100 mL of sulfuric acid (sp gr 1.84), and 400 mL of water. See **Note 5**.

NOTE 5—To avoid injury, prepare the solution by slowly adding the sulfuric acid to the water with continuous stirring. Cool, then add the hydrochloric acid slowly with continuous stirring. The solution shall be at room temperature. Dip the coupons in the solution for 1 to 3 min.

9.5.4.3 Technique No. 3—Steel (This technique or Technique No. 1 may be used for postcleaning only the tested steel coupons.) Use one of the following two solutions:

(1) **Solution No. 1**—Add 100 mL of sulfuric acid (sp gr 1.84), 1.5 mL organic inhibitor, and water to make a 1-L solution. Maintain the solution at 50 ± 2°C (120 ± 3.6°F). Dip the coupons in this solution.

(2) **Solution No. 2** (Clarke's solution)—Add 20 g (0.71 oz) of antimony trioxide and 50 g (1.76 oz) of stannous chloride to 1 L of hydrochloric acid (sp gr 1.19). Stir the solution and use it at room temperature. Dip the coupons for up to 25 min in this solution, while stirring the solution at a rate so that deformation of the coupons does not occur.

9.5.4.4 Technique No. 4—Aluminum (This technique or Technique No. 1 can be used for postcleaning only the tested aluminum coupons.) Make a 1-L solution by adding 20 g (0.71 oz) of chromic acid and 50 mL of phosphoric acid (sp gr 1.69) to water. Maintain the solution at 80 ± 2°C (176 ± 3.6°F). Dip the coupons in this for 5 to 10 min. If a film remains, dip the coupons in nitric acid (sp gr 1.42) for 1 min. Repeat the chromic acid dip. If there are no deposits, use nitric acid alone.

9.5.5 Inspection—After cleaning the metal coupons, examine the coupons over a 40-W light bulb for perforations. Ignore notches that extend into the coupon 3 mm (0.12 in.) or less from any edge.

9.6 Report—The report shall include the following:

9.6.1 Description of the insulation tested,

9.6.2 Test method for corrosiveness used, and

9.6.3 The absence or presence of perforations of or by the metal coupons. Notches extending into the coupon 3 mm (0.12 in.) or less from any edge shall be ignored. The absence or presence or perforation by type of metal coupon may also be reported.

9.7 Precision and Bias—No statement is made about the precision and bias of this test method since it is a qualitative method and no numerical value is obtained.

10. Critical Radiant Flux

10.1 The critical radiant flux of the insulation shall be determined in accordance with Test Method **E 970**.

10.2 **Sample Preparation:**

10.2.1 Condition specimens in accordance with Test Method **E 970** section 11.

10.2.2 **Procedures:**

10.2.2.1 **Method A**—Blow the material through a commercial blower using 30.5 m (100 ft) of 5.08-cm (2-in.) diameter hose into a sample receiver while holding the hose horizontally at a height of 4 ft. Hand load the specimen tray, being careful not to compact the insulation.

10.2.2.2 **Method B**—Blow the material through a commercial blower using 30.5 m (100 ft.) of 5.08-cm. (2-in.) diameter hose directly into the specimen tray while holding the hose horizontally at a height of 4 ft.

10.2.3 Gently shake specimen, removing excess and over-blown insulation. The specimen shall then be gently screeded with a metal straight edge in one direction so that the specimen is level across the top of the tray. Surface irregularities shall not exceed 4.8 mm (3/16 in.). Additional material may be added to fill any voids or valleys around the periphery of the specimen tray. Take care not to compact the insulation. The tray may now be inserted in the radiant panel. As an alternative to screeding, the specimen tray may be gently dropped onto a hard level surface until the specimen is level with the sides of the specimen tray.

11. Fungi Resistance

11.1 **Scope**—This test method covers the determination of the amount of resistance to the growth of fungi present in cellulosic loose-fill insulation materials.

11.2 **Significance and Use**—It is necessary to ensure that cellulosic loose-fill insulation materials support no greater growth of fungi than the surrounding materials of the structure being insulated. Normally the structural materials in question will be wood. Excessive growth of fungi on the insulation could result in loss of efficiency of the insulation, damage to the structure, and possible health hazards to the occupants of the insulated structure. The purpose of this test method is to provide an evaluation of the potential for fungi growth present in the insulation material relative to common wood use for framing.

11.3 **Apparatus**—The apparatus required to conduct this test method consists of chambers or cabinets together with auxiliary instrumentation capable of maintaining the specified conditions of temperature and humidity.

11.4 **Sampling**—Unless specified by the purchaser, one specimen shall be selected from each of three different bags or other packages of insulation, as applicable.

11.5 **Procedure:**

11.5.1 Prepare mineral-salts agar in accordance with **Table 2**.

11.5.1.1 Sterilize the mineral-salts agar by autoclaving at 121°C (250°F) for 20 min. Adjust the pH of the solution with 0.01 normal solution of NaOH so that after sterilization the pH is from 6.0 to 6.5. Reagent grade chemicals shall be used in all tests. Unless otherwise specified, it is intended that all reagents shall conform to the specifications of the Committee on Analytical Reagents of the American Chemical Society, where such specifications are available.⁴