



Designation: D 4194 – 95 (Reapproved 2001)

Standard Test Methods for Operating Characteristics of Reverse Osmosis Devices¹

This standard is issued under the fixed designation D 4194; the number immediately following the designation indicates the year of original adoption or, in the case of revision, the year of last revision. A number in parentheses indicates the year of last reapproval. A superscript epsilon (ϵ) indicates an editorial change since the last revision or reapproval.

1. Scope

1.1 These test methods cover the determination of the operating characteristics of reverse osmosis devices using standard test conditions and are not necessarily applicable to natural waters. Two test methods are given, as follows:

	Sections
Test Method A—Brackish Water Reverse Osmosis Devices	8-13
Test Method B—Seawater Reverse Osmosis Devices	14-19

1.2 *This standard does not purport to address all of the safety concerns, if any, associated with its use. It is the responsibility of the user of this standard to establish appropriate safety and health practices and determine the applicability of regulatory limitations prior to use.*

2. Referenced Documents

2.1 *ASTM Standards:*

D 512 Test Methods for Chloride Ion in Water²

D 1125 Test Methods for Electrical Conductivity and Resistivity of Water²

D 1129 Terminology Relating to Water²

D 1193 Specification for Reagent Water²

3. Terminology

3.1 *Definitions*—For definitions of terms used in these test methods, refer to Terminology D 1129.

3.2 *Definitions of Terms Specific to This Standard:*

3.2.1 *concentrate, reject, or brine*—that portion of feed which does not pass through the membrane.

3.2.2 *conversion or recovery*—the ratio of permeate flow rate to feed flow rate, expressed as percent.

3.2.3 *desalination device*—a single pressure vessel containing a reverse osmosis element or elements and supporting materials.

3.2.4 *device pressure drop (ΔP)*—the difference between the feed pressure and the concentrate pressure.

3.2.5 *feed*—the solution that enters the device.

3.2.6 *permeate*—that portion of the feed which passes through the membrane.

3.2.7 *permeate flow rate*—the quantity of permeate produced per unit time.

3.2.8 *rejection*—that portion of the salt in the feed which does not pass through the reverse osmosis membrane, expressed as percent and is equal to (100 % – salt passage).

3.2.9 *salt passage*—the ratio of permeate salt concentration to feed salt concentration, expressed as percent.

4. Summary of Test Methods

4.1 These test methods consist of determining the desalinating ability and permeate flow rate of reverse osmosis devices. They are applicable to both new and used reverse osmosis devices.

5. Significance and Use

5.1 Reverse osmosis desalinating devices can be used to produce potable water from brackish supplies (<10 000 mg/L) and seawater as well as to upgrade the quality of industrial water. These test methods permit the measurement of the performance of reverse osmosis devices using standard sets of conditions and are intended for short-term testing (<24 h). These test methods can be used to determine changes that may have occurred in the operating characteristics of reverse osmosis devices but are not intended to be used for plant design.

6. Reagents

6.1 *Purity of Reagents*—Reagent grade chemicals shall be used in all tests. Unless otherwise indicated, it is intended that all reagents shall conform to the specifications of the Committee on Analytical Reagents of the American Chemical Society, where such specifications are available.³ Other grades may be used, provided it is first ascertained that the reagent is of sufficiently high purity to permit its use without lessening the accuracy of the determination.

6.2 *Purity of Water*—Unless otherwise indicated, references

¹ These test methods are under the jurisdiction of ASTM Committee D19 on Water, and are the direct responsibilities of Subcommittee D19.08 on Membranes and Ion Exchange Materials.

Current edition approved April 15, 1995. Published June 1995. Originally published as D 4194 – 82. Last previous edition D 4194 – 89 (1994).

² *Annual Book of ASTM Standards*, Vol 11.01.

³ *Reagent Chemicals, American Chemical Society Specifications*, American Chemical Society, Washington, DC. For suggestions on the testing of reagents not listed by the American Chemical Society, see *Analar Standards for Laboratory Chemicals*, BDH Ltd., Poole, Dorset, U.K., and the *United States Pharmacopeia and National Formulary*, U.S. Pharmaceutical Convention, Inc. (USPC), Rockville, MD.

to water shall be understood to mean Type III reagent conforming to Specification D 1193.

7. Apparatus

7.1 The apparatus for both methods is schematically described in Fig. 1 and Fig. 2. A conductivity meter can be used to determine the salt concentration in accordance with Test Methods D 1125.

7.2 Installation:

7.2.1 Materials of construction shall be of high-quality stainless steel (Type 316) or plastic for all wetted parts to prevent contamination of the feed solution by corrosion products. Do not use reactive piping material such as plain carbon steel, galvanized or cadmium-plated carbon steel, and cast iron for piping. Take care to ensure that no contamination will occur from oil films on new metal piping, release agents on raw

plastic components, or from feed solutions previously used in the system. If materials are suspect, thoroughly clean or degrease or both, before use. All pressurized components whether stainless steel or plastic should be designed based on the manufacturer's working pressure rating. Review manufacturer's rating for compliance with standard engineering practice.

7.2.2 The reverse osmosis testing apparatus, represented schematically in Fig. 1 using a centrifugal pump, consists of a feed holding tank equipped with a thermostated heat exchanger system to maintain the feed solution at the desired temperature, a booster pump, a high-pressure centrifugal pump, and a reverse osmosis device. Use a valve with a minimum flow restriction (for example, ball valve or plug valve) for the shut-off valve to prevent excessive pressure drop.

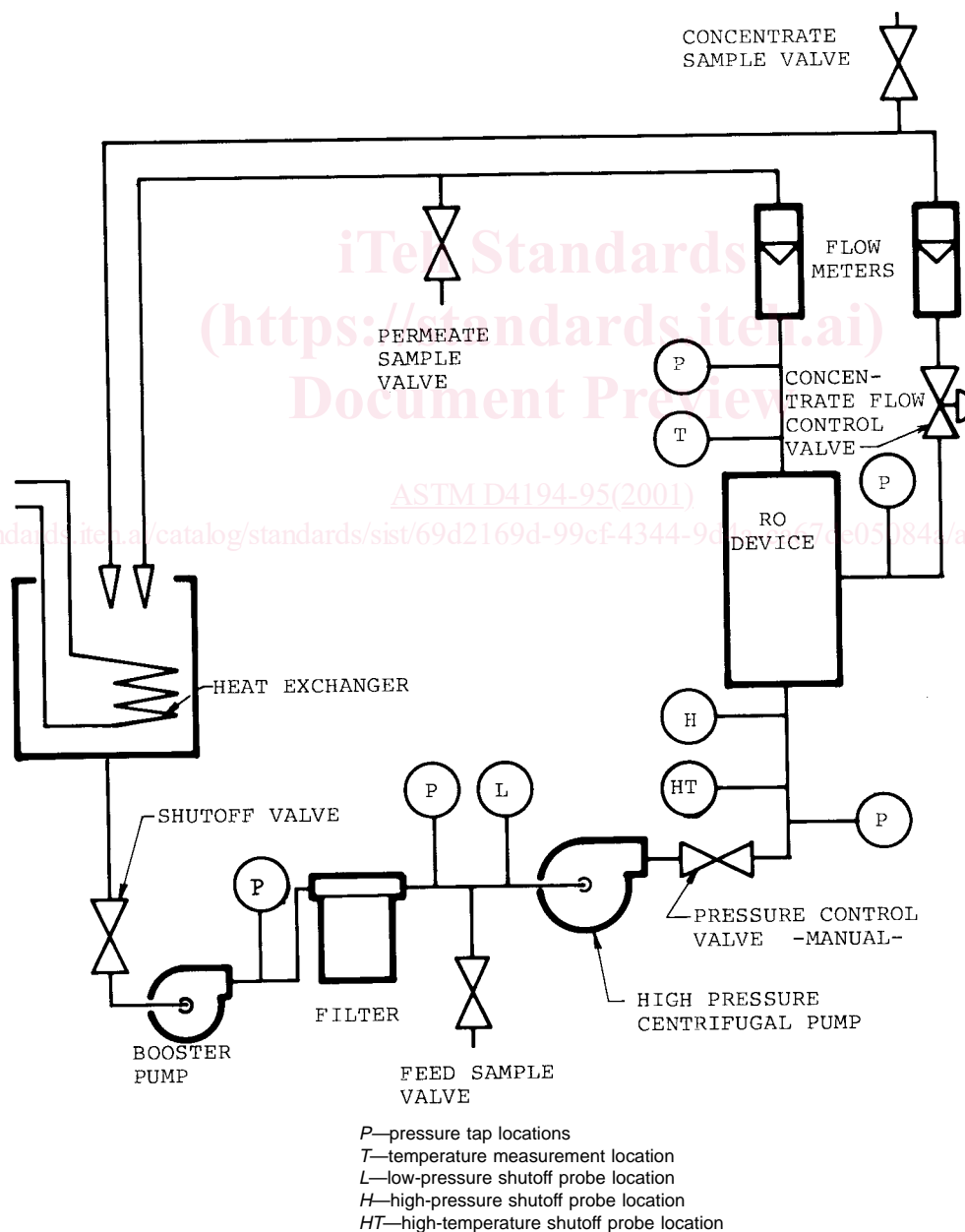

FIG. 1 Centrifugal High-Pressure Pump System Piping Diagram

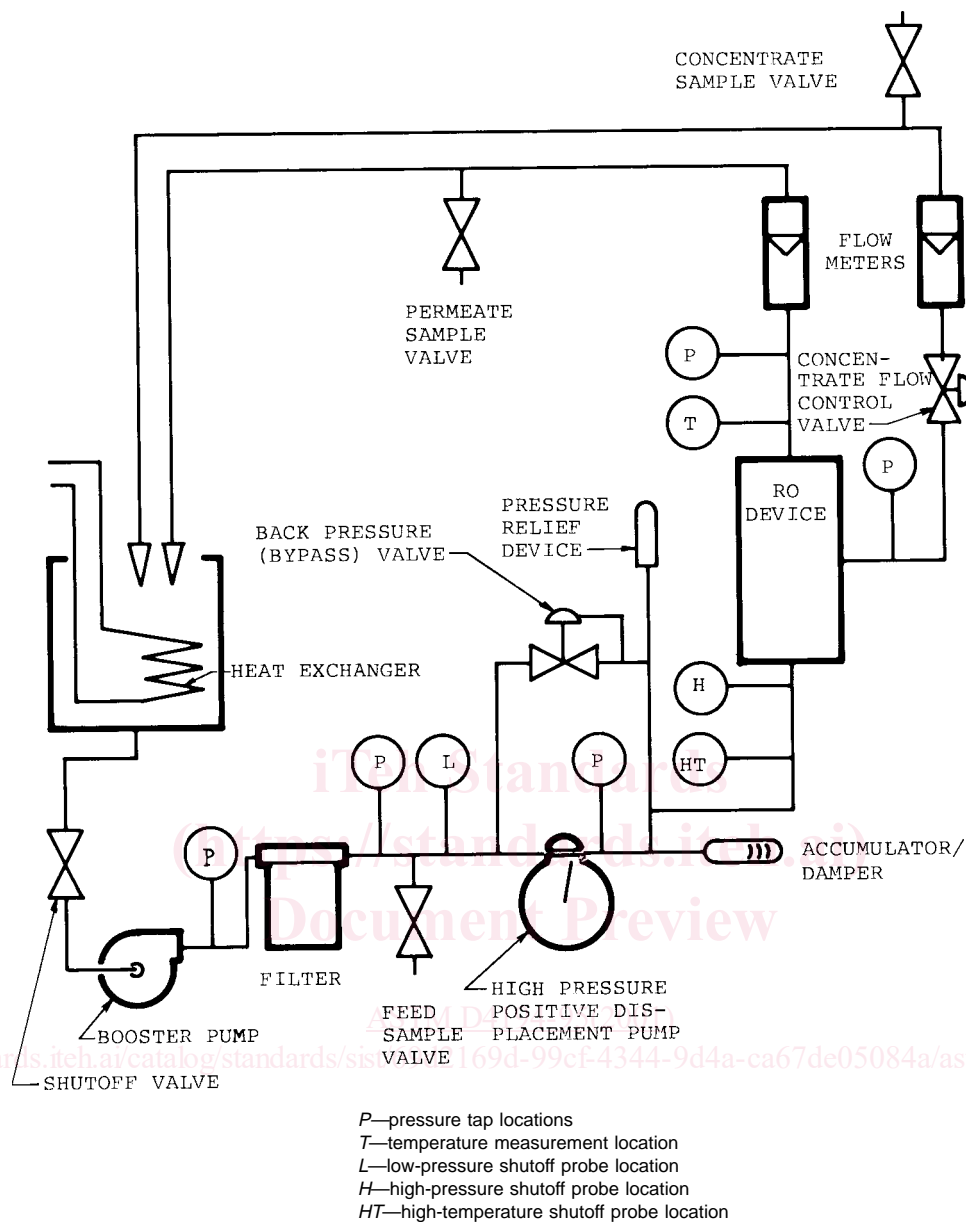

FIG. 2 Positive Displacement High-Pressure Pump System Piping Diagram

The filter can be either a strainer (100-mesh) or a 5- μm filter (based on supplier's recommendation). Use a pressure control valve such as a ball valve for throttling the pump discharge. A flow control valve is needed to regulate the concentrate flow. A manual throttling valve, such as a needle valve, is sufficient for this application unless the flows are so low that plugging could become a problem. In that case, use a long coil of high-pressure media tubing to take the entire pressure drop through the tubing. Cut the tubing to length for the required flow.

7.2.3 See Fig. 2 for a schematic piping diagram for a positive displacement high-pressure pump test system. Valves and arrangements are similar to the centrifugal system except for the high-pressure pump piping. The back-pressure regulator on the by-pass controls pressure on the pump discharge line. Under no circumstances install throttling valves directly on a positive displacement pump discharge line. An accumulator is required to minimize pressure pulsations (<1 % of value) if a

reciprocating piston-type positive displacement pump is used to feed the reverse osmosis device.

7.2.4 Operate the apparatus by drawing the feed solution from the tank and pumping it through the reverse osmosis device under pressure. Return both the concentrate stream and the permeate to the feed tank so that its volume and solute concentration remain constant. Use the heat exchanger coils in the feed tank to adjust the feed to specified operating temperature and thereafter use to remove the energy load generated by the pump. Monitor the permeate temperature very near the reverse osmosis device (within 500 mm). Pressure gages before and after the reverse osmosis device give the feed pressure and the pressure drop across the device (ΔP ; feed pressure – concentrate pressure). Locate these gages as close as possible to the reverse osmosis device. Measure the concentrate and permeate flow rates with calibrated flowmeters from which the feed rate to the device may be determined.