

---

---

**Rolling bearings — Cast and pressed  
 housings for insert bearings —  
 Boundary dimensions and tolerances**

*Roulements — Logements moulés et emboutis pour roulements  
 “insert” — Dimensions d’encombrement et tolérances*

**iTeh STANDARD PREVIEW**  
**(standards.iteh.ai)**

[ISO 3228:2013](https://standards.iteh.ai/catalog/standards/sist/3eaf2124-92cb-4804-8ae0-b939229ab884/iso-3228-2013)

[https://standards.iteh.ai/catalog/standards/sist/3eaf2124-92cb-4804-8ae0-  
b939229ab884/iso-3228-2013](https://standards.iteh.ai/catalog/standards/sist/3eaf2124-92cb-4804-8ae0-b939229ab884/iso-3228-2013)



**iTeh STANDARD PREVIEW**  
**(standards.iteh.ai)**

ISO 3228:2013

<https://standards.iteh.ai/catalog/standards/sist/3eaf2124-92cb-4804-8ae0-b939229ab884/iso-3228-2013>



**COPYRIGHT PROTECTED DOCUMENT**

© ISO 2013

All rights reserved. Unless otherwise specified, no part of this publication may be reproduced or utilized otherwise in any form or by any means, electronic or mechanical, including photocopying, or posting on the internet or an intranet, without prior written permission. Permission can be requested from either ISO at the address below or ISO's member body in the country of the requester.

ISO copyright office  
Case postale 56 • CH-1211 Geneva 20  
Tel. + 41 22 749 01 11  
Fax + 41 22 749 09 47  
E-mail [copyright@iso.org](mailto:copyright@iso.org)  
Web [www.iso.org](http://www.iso.org)

Published in Switzerland

# Contents

	Page
<b>Foreword</b> .....	<b>iv</b>
<b>1 Scope</b> .....	<b>1</b>
<b>2 Normative references</b> .....	<b>1</b>
<b>3 Terms and definitions</b> .....	<b>1</b>
<b>4 Symbols</b> .....	<b>1</b>
4.1 General .....	1
4.2 Cast plumber block housing .....	2
4.3 Cast flanged housing, square .....	2
4.4 Cast flanged housing, oval .....	2
4.5 Cast take-up housing .....	3
4.6 Pressed plumber block housing .....	3
4.7 Pressed flanged housings, round, triangular and oval .....	4
<b>5 Boundary dimensions and tolerances</b> .....	<b>4</b>
5.1 General .....	4
5.2 Cast housings .....	4
5.3 Pressed housings .....	14
<b>Bibliography</b> .....	<b>16</b>

## iTeh STANDARD PREVIEW (standards.iteh.ai)

[ISO 3228:2013](https://standards.iteh.ai/catalog/standards/sist/3eaf2124-92cb-4804-8ae0-b939229ab884/iso-3228-2013)

<https://standards.iteh.ai/catalog/standards/sist/3eaf2124-92cb-4804-8ae0-b939229ab884/iso-3228-2013>

## Foreword

ISO (the International Organization for Standardization) is a worldwide federation of national standards bodies (ISO member bodies). The work of preparing International Standards is normally carried out through ISO technical committees. Each member body interested in a subject for which a technical committee has been established has the right to be represented on that committee. International organizations, governmental and non-governmental, in liaison with ISO, also take part in the work. ISO collaborates closely with the International Electrotechnical Commission (IEC) on all matters of electrotechnical standardization.

International Standards are drafted in accordance with the rules given in the ISO/IEC Directives, Part 2.

The main task of technical committees is to prepare International Standards. Draft International Standards adopted by the technical committees are circulated to the member bodies for voting. Publication as an International Standard requires approval by at least 75 % of the member bodies casting a vote.

Attention is drawn to the possibility that some of the elements of this document may be the subject of patent rights. ISO shall not be held responsible for identifying any or all such patent rights.

ISO 3228 was prepared by Technical Committee ISO/TC 4, *Rolling bearings*, Subcommittee SC 6, *Insert bearings*.

This fourth edition cancels and replaces the third edition (ISO 3228:1993), which has been technically revised. In particular, this fourth edition has been extended. Boundary dimensions and tolerances of cast housings for diameter series 3 have been added in [Tables 2, 4, 6 and 8](#). In addition, boundary dimensions and tolerances of larger size cast flanged housings, oval and cast take-up housings for diameter series 2 have been added in [Tables 5 and 7](#).

[ISO 3228:2013](#)

<https://standards.iteh.ai/catalog/standards/sist/3eaf2124-92cb-4804-8ae0-b939229ab884/iso-3228-2013>

# Rolling bearings — Cast and pressed housings for insert bearings — Boundary dimensions and tolerances

## 1 Scope

This International Standard specifies boundary dimensions and tolerances for cast and pressed housings for insert bearings for which boundary dimensions are given in ISO 9628[1].

It applies to plummer block housings, flanged housings and take-up housings.

The inclusion of relubrication features is optional, but when provided it is intended that they intersect the zone specified in ISO 9628[1] in such a way that lubricant satisfactorily feeds from the housing through this zone. The exact design of the relubrication features is not otherwise covered by this International Standard.

## 2 Normative references

The following documents, in whole or in part, are normatively referenced in this document and are indispensable for its application. For dated references, only the edition cited applies. For undated references, the latest edition of the referenced document (including any amendments) applies.

ISO 5593, *Rolling bearings — Vocabulary*

ISO 15241, *Rolling bearings — Symbols for quantities*

## 3 Terms and definitions

For the purposes of this document, the terms and definitions given in ISO 5593 apply.

## 4 Symbols

### 4.1 General

For the purposes of this document, the symbols given in ISO 15241 and those in 4.2 to 4.7 apply.

The symbols (except those for tolerances) shown in Figures 1 to 6, and the values given in Tables 1 to 10 denote nominal dimensions, unless specified otherwise.

NOTE Figures 1 to 6 are drawn schematically and do not necessarily show all design details. The grease nipple positions in Figures 1 to 4 are examples. Other positions are at the discretion of the manufacturer.

## 4.2 Cast plumber block housing

See [Figure 1](#) and [Tables 1](#) and [2](#).

$A$	(overall) width of base
$D_a$	spherical seating diameter of housing
$H$	distance from mounting base to centreline of spherical seating diameter
$H_1$	height of feet
$J$	centre distance between bolt holes
$L$	(overall) length of base
$N$	width of bolt hole
$N_1$	length of bolt hole
$\Delta_{Hs}$	deviation of single distance from mounting base to centreline of spherical seating diameter

## 4.3 Cast flanged housing, square

See [Figure 2](#) and [Tables 3](#) and [4](#).

$A$	(overall) width
$A_1$	width of flange
$A_2$	distance from mounting face to centreline of spherical seating diameter
$D_a$	spherical seating diameter of housing
$J$	centre distance between bolt holes
$L$	(overall) length
$N$	diameter of bolt hole
$X$	position tolerance of bolt holes
$\Delta_{A2s}$	deviation of single distance from mounting face to centreline of spherical seating diameter

## 4.4 Cast flanged housing, oval

See [Figure 3](#) and [Tables 5](#) and [6](#).

$A$	(overall) width
$A_1$	width of flange
$A_2$	distance from mounting face to centreline of spherical seating diameter
$D_a$	spherical seating diameter of housing
$H$	height of flange

$J$	centre distance between bolt holes
$L$	(overall) length
$N$	diameter of bolt hole
$X$	position tolerance of bolt holes
$\Delta_{A2s}$	deviation of single distance from mounting face to centreline of spherical seating diameter

#### 4.5 Cast take-up housing

See [Figure 4](#) and [Tables 7](#) and [8](#).

$A$	(overall) width (attachment end)
$A_1$	width of location slot
$A_2$	width of flange in which location slot is provided
$D_a$	spherical seating diameter of housing
$H$	(overall) height
$H_1$	distance between bottoms of location slots
$H_2$	height (attachment end)
$L$	(overall) length
$L_1$	distance from attachment end face to centreline of spherical seating diameter
$L_2$	length (attachment end)
$L_3$	length of location slot
$N$	diameter of attachment hole
$N_1$	length of attachment slot
$N_2$	height of attachment slot
$\Delta_{H1s}$	deviation of single distance between bottoms of location slots

#### 4.6 Pressed plummer block housing

See [Figure 5](#) and [Table 9](#).

$A$	(overall) width of base
$D_a$	spherical seating diameter of housing
$H$	distance from mounting base to centreline of spherical seating diameter
$H_1$	height of feet
$J$	centre distance between bolt holes
$L$	(overall) length of base

$N$	diameter of bolt hole
$\Delta_{Js}$	deviation of single centre distance between bolt holes
$\Delta_{Ns}$	deviation of single diameter of bolt hole

#### 4.7 Pressed flanged housings, round, triangular and oval

See [Figure 6](#) and [Table 10](#).

$A$	(overall) width
$A_1$	width of flange
$D_a$	spherical seating diameter of housing
$H$	height (round, triangular, oval)
$H_1$	distance from straight edge to centreline of spherical seating diameter (triangular)
$H_2$	limit diameter of flat surface
$J$	pitch circle diameter of bolt holes (round and triangular); centre distance between bolt holes (oval)
$L$	(overall) length of flange (oval)
$N$	side dimension of square bolt hole
$\Delta_{Js}$	deviation of single pitch circle diameter of bolt holes (round and triangular); deviation of single centre distance between bolt holes (oval)
$\Delta_{Ns}$	deviation of single side dimension of square bolt hole

ITEH STANDARD PREVIEW

(standards.iteh.ai)

ISO 3228:2013

<https://standards.iteh.ai/catalog/standards/sist/3eaf2124-92cb-4804-8ae0-b93822f4e884/iso-3228-2013>

## 5 Boundary dimensions and tolerances

### 5.1 General

Boundary dimensions and tolerances are given in [Tables 1](#) to [10](#).

Where “max.” is shown in [Tables 1](#) to [10](#), this indicates that the value is both the nominal value and the largest actual value permitted. Where “min.” is shown in [Tables 1](#) to [8](#), this indicates that the value is both the nominal value and the smallest actual value permitted.

### 5.2 Cast housings

Boundary dimensions and tolerances for cast housings are given in [Tables 1](#) to [8](#).



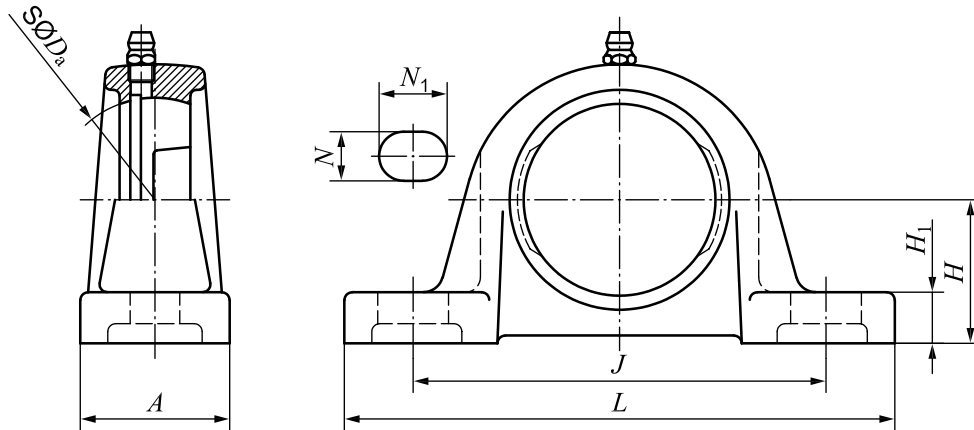

Figure 1 — Cast plummer block housing

Table 1 — Cast plummer block housings — Diameter series 2

Dimensions and tolerance values in millimetres

$D_a$	$L$	$A$	$J$	$H$	$\Delta_{H_s}$	$H_1$	$N$		$N_1$
	max.	max.				max.	min.	max.	min.
40	129	39	96	30,2	$\pm 0,25$	17	10,5	12,5	16
47	134	39	96	33,3	$\pm 0,25$	17	10,5	12,5	16
52	142	39	105	36,5	$\pm 0,25$	17	10,5	12,5	16
62	167	48	121	42,9	$\pm 0,25$	20	13	15	19
72	172	48	126	47,6	$\pm 0,25$	20	13	15	19
80	186	55	136	49,2	$\pm 0,25$	20	13	15	19
85	192	55	146	54	$\pm 0,3$	22	13	15	19
90	208	61	159	57,2	$\pm 0,3$	23	17	19,5	20,5
100	233	61	172	63,5	$\pm 0,3$	25	17	19,5	20,5
110	243	71	186	69,9	$\pm 0,3$	27	17	19,5	22
120	268	73	203	76,2	$\pm 0,3$	34	21	25	24
125	274	74	210	79,4	$\pm 0,3$	34	21	25	24
130	300	83	217	82,6	$\pm 0,35$	35	21	25	24
140	305	84	232	88,9	$\pm 0,35$	38	21	25	24
150	330	95	247	95,2	$\pm 0,35$	41	21	25	24
160	356	100	262	101,6	$\pm 0,35$	44	25	29	34
180	390	111	308	115	$\pm 0,35$	46	25	29	34

**Table 2 — Cast plummer block housings — Diameter series 3**

Dimensions and tolerance values in millimetres

$D_a$	$L$	$A$	$J$	$H$	$\Delta H_s$	$H_1$	$N$		$N_1$
	max.	max.				max.	min.	max.	min.
62	177	47	132	45	$\pm 0,25$	18	15,5	18,5	18
72	182	52	140	50	$\pm 0,25$	21	15,5	18,5	18
80	212	58	160	56	$\pm 0,3$	23	15,5	18,5	23
90	222	62	170	60	$\pm 0,3$	25	15,5	18,5	25
100	247	69	190	67	$\pm 0,3$	27	18,5	21,5	28
110	278	77	212	75	$\pm 0,3$	30	18,5	21,5	33
120	313	82	236	80	$\pm 0,3$	33	18,5	21,5	36
130	333	87	250	85	$\pm 0,35$	35	23,5	26,5	36
140	343	92	260	90	$\pm 0,35$	38	23,5	26,5	36
150	363	92	280	95	$\pm 0,35$	42	25,5	28,5	38
160	383	102	290	100	$\pm 0,35$	42	25,5	28,5	38
170	403	112	300	106	$\pm 0,35$	47	25,5	28,5	38
180	424	112	320	112	$\pm 0,35$	47	31,5	34,5	43
190	434	122	330	118	$\pm 0,35$	52	31,5	34,5	43
200	474	122	360	125	$\pm 0,4$	52	34,5	37,5	48
					ISO 3228:2013				
215	494	132	380	140	$\pm 0,4$	57	34,5	37,5	48
225	494	132	380	140	$\pm 0,4$	57	34,5	37,5	48
240	524	142	400	150	$\pm 0,4$	62	38,5	41,5	53
260	574	142	450	160	$\pm 0,4$	72	38,5	41,5	53
280	604	142	480	180	$\pm 0,4$	82	38,5	41,5	53
300	624	142	500	200	$\pm 0,46$	82	38,5	41,5	53

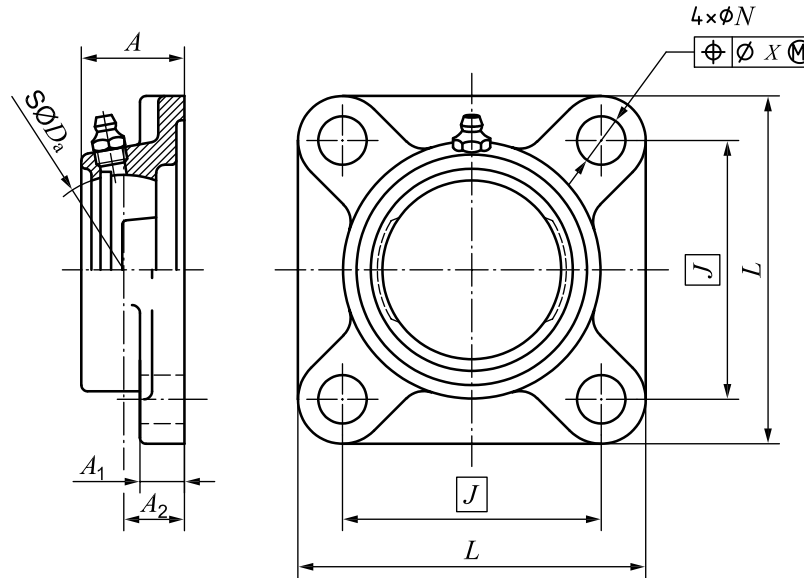

Figure 2 — Cast flanged housing, square

Table 3 — Cast flanged housings, square — Diameter series 2

Dimensions and tolerance values in millimetres

$D_a$	$L$	$A$	$J$	$A_1$	$A_2$	$\Delta_{A_{2s}}$	$N$		$X$
							min.	max.	
	max.	max.		max.					
40	78	32	54	13	17	$\pm 0,43$	10,5	12,5	0,6
47	88	34	63,5	15	19	$\pm 0,52$	10,5	12,5	0,6
52	97	35	70	15	19	$\pm 0,52$	11,5	12,5	0,6
62	110	38	82,5	16	20	$\pm 0,52$	11,5	12,5	0,6
72	119	38	92	17	21	$\pm 0,52$	13	15	0,8
80	132	43	101,5	17	24	$\pm 0,52$	13	15	0,8
85	139	45	105	18	24	$\pm 0,52$	13	17	0,8
90	145	48	111	20	28	$\pm 0,52$	17	19,5	0,8
100	164	51	130	21	31	$\pm 0,62$	17	19,5	0,8
110	177	55	143	21	34	$\pm 0,62$	17	19,5	0,8
120	189	55	149,5	24	34	$\pm 0,62$	17	19,5	0,8
125	195	57	152	24	35	$\pm 0,62$	17	20	0,8
130	202	58	159	24	35	$\pm 0,62$	17	25	0,8
140	213	65	165	24	35	$\pm 0,62$	21	25	0,8
150	222	75	175	26	36	$\pm 0,62$	21	25	0,8
160	240	75	187	27	42	$\pm 0,62$	21	25	0,8
180	270	80	210	29	44	$\pm 0,62$	25	29	0,8