



**Broadcast Sound Receivers;  
Part 1: Generic requirements and measuring methods**

*ITeH STANDARD PREVIEW  
(standards.iteh.ai)  
Full standard:  
<https://standards.iteh.ai/catalog/standards/sist/675187-4341-4e14-b320-bc3aa14d2217/etsi-en-303-345-1-v1.1.1-2019-06>*

---

**Reference**DEN/ERM-TG17-151

---

---

**Keywords**broadcast, digital, radio, receiver

---

**ETSI**

650 Route des Lucioles  
F-06921 Sophia Antipolis Cedex - FRANCE

---

Tel.: +33 4 92 94 42 00 Fax: +33 4 93 65 47 16

Siret N° 348 623 562 00017 - NAF 742 C  
Association à but non lucratif enregistrée à la  
Sous-Préfecture de Grasse (06) N° 7803/88

---

**Important notice**

---

The present document can be downloaded from:

<http://www.etsi.org/standards-search>

The present document may be made available in electronic versions and/or in print. The content of any electronic and/or print versions of the present document shall not be modified without the prior written authorization of ETSI. In case of any existing or perceived difference in contents between such versions and/or in print, the prevailing version of an ETSI deliverable is the one made publicly available in PDF format at [www.etsi.org/deliver](http://www.etsi.org/deliver).

Users of the present document should be aware that the document may be subject to revision or change of status.

Information on the current status of this and other ETSI documents is available at

<https://portal.etsi.org/TB/ETSIDeliverableStatus.aspx>

If you find errors in the present document, please send your comment to one of the following services:

<https://portal.etsi.org/People/CommiteeSupportStaff.aspx>

---

**Copyright Notification**

---

No part may be reproduced or utilized in any form or by any means, electronic or mechanical, including photocopying and microfilm except as authorized by written permission of ETSI.

The content of the PDF version shall not be modified without the written authorization of ETSI.

The copyright and the foregoing restriction extend to reproduction in all media.

© ETSI 2019.

All rights reserved.

**DECT™**, **PLUGTESTS™**, **UMTS™** and the ETSI logo are trademarks of ETSI registered for the benefit of its Members.

**3GPP™** and **LTE™** are trademarks of ETSI registered for the benefit of its Members and of the 3GPP Organizational Partners.

**oneM2M™** logo is a trademark of ETSI registered for the benefit of its Members and of the oneM2M Partners.

**GSM®** and the GSM logo are trademarks registered and owned by the GSM Association.

# Contents

Intellectual Property Rights .....	4
Foreword.....	4
Modal verbs terminology.....	5
1 Scope .....	6
2 References .....	6
2.1 Normative references .....	6
2.2 Informative references.....	6
3 Definition of terms, symbols and abbreviations.....	7
3.1 Terms.....	7
3.2 Symbols.....	7
3.3 Abbreviations .....	7
4 Technical requirements specifications .....	8
4.1 Environmental profile.....	8
4.2 Conformance requirements .....	8
4.2.1 Broadcast radio modulation methods.....	8
4.2.2 Broadcast radio frequency bands .....	8
5 Testing for compliance with technical requirements.....	9
5.1 Environmental conditions for testing .....	9
5.2 Interpretation of the measurement results .....	9
5.3 Methods of measurement .....	9
5.3.1 Generic methods of measurement.....	9
5.3.2 Generic measurement set-up for radiated testing.....	10
5.3.3 Generic measurement set-up for conducted testing.....	13
5.3.4 Sensitivity measurement methods.....	14
5.3.4.1 Analogue (AM and FM) sensitivity measurements.....	14
5.3.4.2 Digital (DAB and DRM) sensitivity measurements.....	14
5.3.5 Adjacent channel selectivity and blocking measurement methods.....	14
5.3.5.1 Analogue (AM and FM) adjacent channel selectivity and blocking measurements .....	14
5.3.5.2 Digital (DAB and DRM) adjacent channel selectivity and blocking measurements.....	15
<b>Annex A (informative): A fibre-optic link for receiver testing.....</b>	<b>16</b>
<b>Annex B (informative): Measurement set-up for electrical methods during radiated testing .....</b>	<b>18</b>
<b>Annex C (informative): Change History .....</b>	<b>19</b>
History .....	20

# Intellectual Property Rights

## Essential patents

IPRs essential or potentially essential to normative deliverables may have been declared to ETSI. The information pertaining to these essential IPRs, if any, is publicly available for **ETSI members and non-members**, and can be found in ETSI SR 000 314: "*Intellectual Property Rights (IPRs); Essential, or potentially Essential, IPRs notified to ETSI in respect of ETSI standards*", which is available from the ETSI Secretariat. Latest updates are available on the ETSI Web server (<https://ipr.etsi.org/>).

Pursuant to the ETSI IPR Policy, no investigation, including IPR searches, has been carried out by ETSI. No guarantee can be given as to the existence of other IPRs not referenced in ETSI SR 000 314 (or the updates on the ETSI Web server) which are, or may be, or may become, essential to the present document.

## Trademarks

The present document may include trademarks and/or tradenames which are asserted and/or registered by their owners. ETSI claims no ownership of these except for any which are indicated as being the property of ETSI, and conveys no right to use or reproduce any trademark and/or tradename. Mention of those trademarks in the present document does not constitute an endorsement by ETSI of products, services or organizations associated with those trademarks.

# Foreword

This final draft European Standard (EN) has been produced by ETSI Technical Committee Electromagnetic compatibility and Radio spectrum Matters (ERM), and is now submitted for the Vote phase of the ETSI standards EN Approval Procedure.

The present document is part 1 of a multi-part deliverable covering the requirements and measuring methods for broadcast sound receivers to meet the essential requirements of article 3.2 of Directive 2014/53/EU [i.1], as identified below:

- Part 1: "Generic requirements and measuring methods";**
- Part 2: "AM broadcast sound service";
- Part 3: "FM broadcast sound service";
- Part 4: "DAB broadcast sound service";
- Part 5: "DRM broadcast sound service".

The test data files are contained in archive en\_30334501v010101v0.zip which accompanies the present document.

<b>Proposed national transposition dates</b>	
Date of latest announcement of this EN (doa):	3 months after ETSI publication
Date of latest publication of new National Standard or endorsement of this EN (dop/e):	6 months after doa
Date of withdrawal of any conflicting National Standard (dow):	18 months after doa

---

## Modal verbs terminology

In the present document "shall", "shall not", "should", "should not", "may", "need not", "will", "will not", "can" and "cannot" are to be interpreted as described in clause 3.2 of the [ETSI Drafting Rules](#) (Verbal forms for the expression of provisions).

"must" and "must not" are **NOT** allowed in ETSI deliverables except when used in direct citation.

**iTeh STANDARD PREVIEW**  
(standards.iteh.ai)  
Full standard:  
<https://standards.iteh.ai/catalog/standards/sist/c75e6a87-4341-4e14-b320-bc3aa14d2217/etsi-en-303-345-1-v1.1.1-2019-06>

---

# 1 Scope

The present document specifies generic requirements and methods of measurements for devices, including the supplied antenna, that receive broadcast sound services, whether analogue or digital modulation is used to meet the essential requirements of article 3.2 of Directive 2014/53/EU [i.1]. Subsequent parts of this multi-part deliverable provide the necessary test signal configurations and limits for the different broadcast sound services. Multi-function devices may also fall under the requirements of other documents.

---

## 2 References

### 2.1 Normative references

References are either specific (identified by date of publication and/or edition number or version number) or non-specific. For specific references, only the cited version applies. For non-specific references, the latest version of the referenced document (including any amendments) applies.

Referenced documents which are not found to be publicly available in the expected location might be found at <https://docbox.etsi.org/Reference/>.

NOTE: While any hyperlinks included in this clause were valid at the time of publication, ETSI cannot guarantee their long term validity.

The following referenced documents are necessary for the application of the present document.

- [1] CENELEC EN 55032:2015: "Electromagnetic compatibility of multimedia equipment - Emission Requirements".
- [2] IEC 60315-1 (1988): "Methods of measurement on radio receivers for various classes of emission. Part 1: General considerations and methods of measurement, including audio-frequency measurements".
- [3] Recommendation ITU-R BS.468-4 (07/1986): "Measurement of audio-frequency noise voltage level in sound broadcasting".

### 2.2 Informative references

References are either specific (identified by date of publication and/or edition number or version number) or non-specific. For specific references, only the cited version applies. For non-specific references, the latest version of the referenced document (including any amendments) applies.

NOTE: While any hyperlinks included in this clause were valid at the time of publication, ETSI cannot guarantee their long term validity.

The following referenced documents are not necessary for the application of the present document but they assist the user with regard to a particular subject area.

- [i.1] Directive 2014/53/EU of the European Parliament and of the Council of 16 April 2014 on the harmonisation of the laws of the Member States relating to the making available on the market of radio equipment and repealing Directive 1999/5/EC.
- [i.2] ETSI TR 100 028 (all parts): "Electromagnetic compatibility and Radio spectrum Matters (ERM); Uncertainties in the measurement of mobile radio equipment characteristics".
- [i.3] ETSI TR 100 028-2: "Electromagnetic compatibility and Radio spectrum Matters (ERM); Uncertainties in the measurement of mobile radio equipment characteristics; Part 2".
- [i.4] ECA table in ERC report 25.

NOTE: Available at [www.efis.dk](http://www.efis.dk).

- [i.5] CISPR 35: "Electromagnetic Compatibility of Multimedia equipment - Immunity Requirements".
- [i.6] BBC Research & Development White Paper WHP 335: "A Fibre-Optic Link for Use During Receiver Testing".

NOTE: Available at <http://downloads.bbc.co.uk/rd/pubs/whp/whp-pdf-files/WHP335.pdf>.

## 3 Definition of terms, symbols and abbreviations

### 3.1 Terms

For the purposes of the present document, the terms given in Directive 2014/53/EU [i.1] and the following apply:

**adjacent channel selectivity:** at a given frequency separation, ratio of the maximum unwanted signal level to the wanted signal level necessary to provide a given level of audio quality

**blocking:** at a given frequency separation, ratio of the maximum AM unwanted signal level to the wanted signal level necessary to provide a given level of audio quality

**built-in antenna:** antenna that cannot be detached from the equipment

**dBm:** decibels relative to 1 mW of power

**external antenna:** antenna designed to be connected to the equipment with the use of a 50  $\Omega$  or 75  $\Omega$  external connector

**integral antenna:** antenna which is detachable from the equipment without the use of any tools, and not using a 50  $\Omega$  or 75  $\Omega$  external connector

NOTE: A device that uses a supplied earphone as the antenna has an integral antenna.

**sensitivity:** minimum wanted signal level required to provide a given level of audio quality

### 3.2 Symbols

Void.

### 3.3 Abbreviations

For the purposes of the present document, the following abbreviations apply:

AM	Amplitude Modulation
AMSS	Amplitude Modulation Signalling System
BBC	British Broadcasting Corporation
BS	Broadcast service (Sound)
CISPR	Comité International Spécial des Perturbations Radioélectriques
CMAD	Common Mode Absorption Device
DAB	Digital Audio Broadcasting
DRM	Digital Radio Mondiale
EC	European Commission
ECA	European Common Allocation
EU	European Union
FAR	Fully Anechoic Room
FM	Frequency Modulation
GTEM	Gigahertz Transverse ElectroMagnetic
HF	High Frequency
IEC	International Electrotechnical Commission
ITU-R	International Telecommunications Union - Radiocommunications
LED	Light Emitting Diode

LF	Low Frequency
MF	Medium Frequency
RDS	Radio Data System
RF	Radio Frequency
RUT	Receiver Under Test
S/PDIF	Sony/Philips Digital InterFace
SAC	Semi Anechoic Chamber
THD	Total Harmonic Distortion
THD+N	Total Harmonic Distortion plus Noise
UI	User Interface
VHF	Very High Frequency

## 4 Technical requirements specifications

### 4.1 Environmental profile

The technical requirements of the present document apply under the environmental profile for operation of the equipment, which shall be declared by the manufacturer.

### 4.2 Conformance requirements

#### 4.2.1 Broadcast radio modulation methods

The following broadcast radio modulation methods are considered feasible within the current authorization regime in Europe:

- Amplitude modulation, with or without AMSS (AM).
- Frequency modulation, with or without RDS (FM).
- Digital Audio Broadcasting (DAB).
- Digital Radio Mondiale (DRM).

Broadcast radio receivers may include demodulation capability for one or more of these modulation methods. Conformance shall only be required for each of the modulation methods included in the receiver.

#### 4.2.2 Broadcast radio frequency bands

The following frequency bands are identified in the ECA table [i.4] for broadcast radio services:

- Low frequency (LF): 148,5 kHz to 283,5 kHz.
- Medium frequency (MF): 526,5 kHz to 1 606,5 kHz.
- High Frequency (HF): 3 950 kHz to 4 000 kHz, 5 900 kHz to 6 200 kHz, 7 200 kHz to 7 450 kHz, 9 400 kHz to 9 900 kHz, 11 600 kHz to 12 100 kHz, 13 570 kHz to 13 870 kHz, 15 100 kHz to 15 800 kHz, 17 480 kHz to 17 900 kHz, 18 900 kHz to 19 020 kHz, 21 450 kHz to 21 850 kHz and 25 670 kHz to 26 100 kHz.
- VHF band I: 47 MHz to 68 MHz.
- VHF band II: 87,5 MHz to 108 MHz.
- VHF band III: 174 MHz to 240 MHz.

Broadcast radio receivers may include tuning capability for one or more of these frequency bands. Conformance shall only be required for each of the frequency bands included in the receiver.



## 5 Testing for compliance with technical requirements

### 5.1 Environmental conditions for testing

The equipment shall be tested under normal test conditions according to the relevant product and basic standards or to the information accompanying the equipment, which are within the manufacturers declared range of humidity, temperature and supply voltage. The test conditions shall be recorded in the test report.

### 5.2 Interpretation of the measurement results

The interpretation of the results recorded in a test report for the measurements described in the present document shall be as follows:

- the measured value related to the corresponding limit will be used to decide whether an equipment meets the requirements of the present document;
- the value of the measurement uncertainty for the measurement of each parameter shall be included in the test report;
- the recorded value of the measurement uncertainty shall be, for each measurement, equal to or less than the figures in table 1.

For the test methods, according to the present document, the measurement uncertainty figures shall be calculated and shall correspond to an expansion factor (coverage factor)  $k = 1,96$  or  $k = 2$  (which provide confidence levels of respectively 95 % and 95,45 % in the case where the distributions characterizing the actual measurement uncertainties are normal (Gaussian)). Principles for the calculation of measurement uncertainty are contained in ETSI TR 100 028 [i.2], in particular in annex D of the ETSI TR 100 028-2 [i.3].

Table 1 is based on such expansion factors.

**Table 1: Maximum measurement uncertainty**

Parameter	Uncertainty
Uncertainty in conducted measurements	$\pm 1$ dB
Uncertainty in radiated measurements	$\pm 6$ dB

### 5.3 Methods of measurement

#### 5.3.1 Generic methods of measurement

Two generic methods of measurement are applicable to verifying the performance of the receiving equipment in question. The conducted test methods shall be used for receivers with an external antenna connector. The radiated test methods shall be used for all other receivers.

For both generic methods, two generators are needed. One provides the wanted signal, and the other the unwanted signal, or interferer (when required). The two signals are combined in such a way as to maintain isolation between the generators. It is necessary to provide calibrated attenuators for control of the individual levels; very often these will be built into the generators. Where the attenuators are external, cable lengths should be kept short to avoid cross-coupling effects.

The tests require the audio output of the receiver to be measured. All tonal controls (user operated and/or preset, for example, vehicle specific equaliser, etc.) shall be set to provide a flat response during the testing. The measurement device for the different modulation methods is given in table 2.

**Table 2: Measurement device requirements**

Modulation method	Measurement device on audio output
Analogue (AM and FM)	quasi-peak detector employing Recommendation ITU-R BS.468-4 [3], clause 1 weighting
Digital (DAB and DRM)	none (listen to audio)

### 5.3.2 Generic measurement set-up for radiated testing

The measurement set-up is shown in figure 1 where © represents the calibration point of the system.

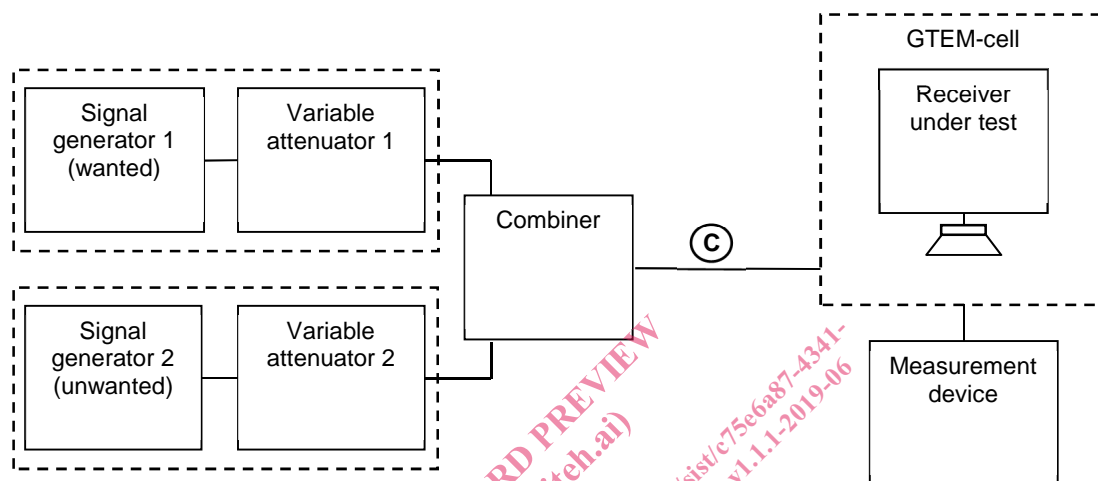

**Figure 1: Generic measurement arrangement for receivers with built-in or integral antennas**

The combiner shall be appropriate for the frequency range of the testing and shall be designed so as to prevent coupling between the two signal generators. Some test houses have experienced difficulties using hybrid combining networks at LF and MF. In such cases a resistive combiner may be appropriate, but care should be taken to ensure the coupling between the generators does not result in unwanted intermodulation products. Hybrid combiners are available for use at LF and MF and these usually give better performance than resistive combining networks.

Signal generator 1 and signal generator 2 may be combined as a single item of test equipment. In this case either the RF signal or the baseband signal may be combined internally, as long as the signal at calibration point © is equivalent to the signal generated in the setup according to figure 1.

The power levels of the two generators are measured at ©. For a 50 Ω system, when the power at © is  $P$  W, the nominal field-strength  $E$  is given by:

$$\frac{\sqrt{50 \times P}}{h}$$

where  $h$  is the height of the cell's septum above its floor in metres. The exact relationship between  $P$  and  $E$  should be obtained from the manufacturer of the cell.

The GTEM cell shall be of sufficient dimensions to provide a uniform field with the antenna fully extended; a minimum floor to ceiling height of 2 m is recommended. Figure 2 shows the usable volume of the GTEM cell.