



Designation: D5458 – 95 (Reapproved 2007)

Standard Test Method for Peel Cling of Stretch Wrap Film¹

This standard is issued under the fixed designation D5458; the number immediately following the designation indicates the year of original adoption or, in the case of revision, the year of last revision. A number in parentheses indicates the year of last reapproval. A superscript epsilon (ϵ) indicates an editorial change since the last revision or reapproval.

1. Scope

1.1 This test method measures cling between two layers of film, in both a stretched and unstretched condition.

1.2 *This standard does not purport to address all of the safety concerns, if any, associated with its use. It is the responsibility of the user of this standard to establish appropriate safety and health practices and determine the applicability of regulatory limitations prior to use.*

2. Referenced Documents

2.1 *ASTM Standards:*²

D996 Terminology of Packaging and Distribution Environments

D1898 Practice for Sampling of Plastics³

D4332 Practice for Conditioning Containers, Packages, or Packaging Components for Testing

E122 Practice for Calculating Sample Size to Estimate, With Specified Precision, the Average for a Characteristic of a Lot or Process

E691 Practice for Conducting an Interlaboratory Study to Determine the Precision of a Test Method

3. Terminology

3.1 *Definitions*—General definitions for packaging and distribution environments are found in Terminology D996.

3.2 *Definitions of Terms Specific to This Standard:*

3.2.1 *cling*—the property of a material's ability to adhere to itself.

3.2.2 *stretch wrap material*—a material used for overwrapping which, when applied under tension, elongates, and through elastic recovery, conforms to the item(s) packaged.

¹ This test method is under the jurisdiction of ASTM Committee D10 on Packaging and is the direct responsibility of Subcommittee D10.25 on Palletizing and Unitizing of Loads.

Current edition approved April 1, 2007. Published May 2007. Originally approved in 1994. Last previous edition approved in 2001 as D5458 – 95 (2001). DOI: 10.1520/D5458-95R07.

² For referenced ASTM standards, visit the ASTM website, www.astm.org, or contact ASTM Customer Service at service@astm.org. For *Annual Book of ASTM Standards* volume information, refer to the standard's Document Summary page on the ASTM website.

³ Withdrawn. The last approved version of this historical standard is referenced on www.astm.org.

4. Summary of Test Method

4.1 This test method is a peel cling procedure. A 1 in. (25 mm) wide film strip is adhered to a flat film attached to an inclined surface. The force required to remove the film strip from the flat film is measured.

5. Significance and Use

5.1 Cling is of critical importance in maintaining a tight wrap after a load is stretch wrapped.

6. Equipment and Preparation

6.1 *Apparatus*—A universal testing machine with a constant rate of grip separation equipped, as follows:

6.1.1 One lightweight jaw equipped with 1 by 1.5 in. (25 by 38 mm) flat rubber-faced grips,

6.1.2 Cling attachment (see Figs. 1-5),

6.1.3 Cling clamp (see Fig. 6),

6.1.4 Load cell, 500-g load capacity,

6.1.5 If using pneumatic grips, air supply, 60 to 70 psi with appropriate filter,

6.1.6 Sample template, picture-frame style with inside dimensions of 5 by 20 in. (125 by 500 mm),

6.1.7 Precision sample cutter, 1 ± 0.001 in. (25.4 ± 0.03 mm) width, with precision of 1 ± 0.001 in. (25.4 ± 0.03 mm),⁴

6.1.8 Single-edged safety razor blade,

6.1.9 Synthetic bristle paint brush, 2 in. (50 mm) wide,

6.1.10 Ruler, 12 in. (approximately 300 mm),

6.1.11 Separation paper, 8.5 by 12 in. (approximately 125 by 280 mm) bond,

6.1.12 String, 24 in. (approximately 610 mm) nonelastic, such as dental floss or fishing line,

6.1.13 Steel rod, approximately 0.25 in. (6 mm) in diameter and 10 in. (255 mm) long.

6.1.14 Cutting surface, approximately 36 by 36 in. (approximately 900 by 900 mm) plate glass, 0.25 in. (6 mm) thick.

6.2 *Preparation of Apparatus:*

6.2.1 Install the load cell on the upper set frame and allow 15-min warm-up period.

6.2.2 Install the upper lightweight jaw.

⁴ JDC-1-10 Cutter is available from Thwing-Albert Instrument Co., 10960 Dutton Rd., Philadelphia, PA 19154 or other manufacturers.

Legend for Figures 1-5:

Item	Quantity	Description	See Sheet No.	Item	Quantity	Description	See Sheet No.
1	1	Base Plate	2	10	2	#8-32 UNF × 1¼ Lg. Fl. Hd. Mach. Screw	
2	1	Incline	3 and 5	11	1	Pulley Spacer Block	4
3	1	¼ I.D. × 1¼ O.D. × ⅛ Thick Flat Washer		12	1	Mounting Stud	4
4	1	Reid #KKT-4B Steel Knob		13	2	¼-20 UNC × 1 Large Socket Head Cap Screw	
5	1	KNU-Vise #H-200 Toggle Clamp		14	2	¼ Lock Washer	
6	4	#8-32 UNF × ⅝ Lg. Rd. Hd. Machine Screw		Finish: All aluminum parts to have fine sandblasted finish.			
7	4	#8 Lock Washers					
8	1	Clamp Bar	4				
9	1	McMaster-Carr #3101T2 Pulley					

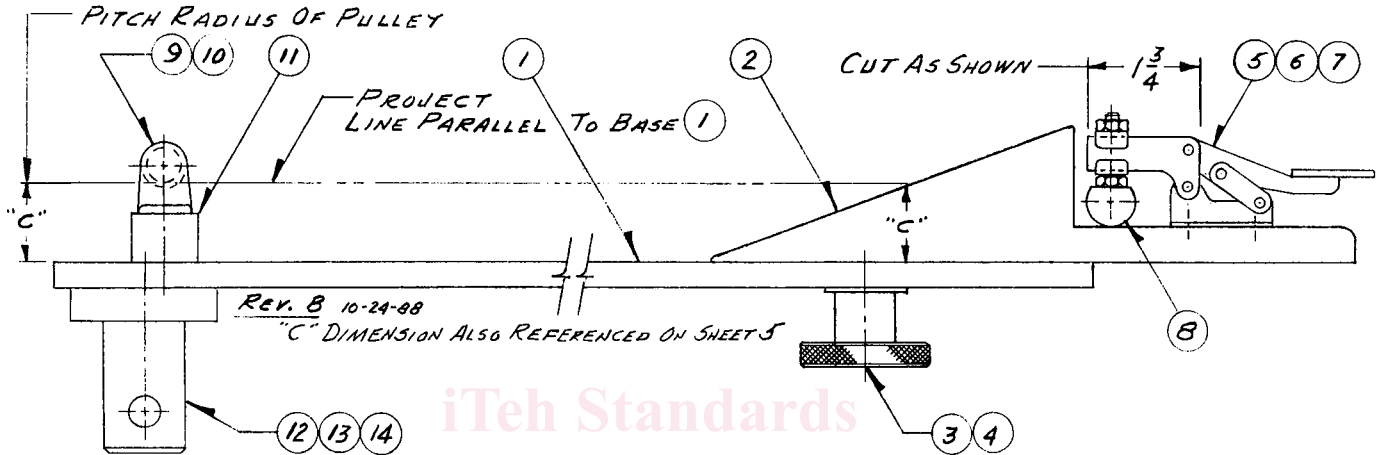

NOTE 1—1 in. = 25 mm.

FIG. 1 Overall Fixture

6.2.3 Remove the lower jaw and install the cling attachment, using the locking pin to secure.

6.2.4 Feed the end of the string not fastened to the clamp through the pulley on the cling attachment and place in the center of the upper jaw.

6.2.5 With the clamp resting at the base of the incline (which is in position on the base plate), adjust the crosshead, or the amount of string pulled through the grips, or both in combination, to achieve a distance of 5 by 7 in. (125 by 180 mm) between the top of the pulley and the bottom of the grips. Tighten the upper jaw. Adjust the crosshead return stop as necessary.

6.2.6 Set the testing machine crosshead speed for 5 in. (125 mm). (Any chart speed is acceptable.)

6.2.7 Zero, balance, and calibrate the tester in accordance with the operator's manual.

7. Sampling

7.1 Acceptance sampling shall be in accordance with Practice D1898.

7.2 Sampling for Other Purposes—The sampling and the number of test specimens depends on the purposes of the testing. Practice E122 is recommended. Test specimens should be taken from several rolls of film, and when possible, from

several production runs of a product. Strong conclusions about a specific property of a film cannot be based on a single roll of product.

8. Test Specimens

8.1 The roll to be tested must have at least three outer wraps removed just prior to sample selection.

8.2 With the film unwinding from the top of the roll, pull about 30 in. (760 mm) of sample film from the roll at a rate of approximately 8 in./s (approximately 200 mm/s). Some films are sensitive to unwind speed so a consistent rate that does not induce appearance variations, such as stripes or bars, is important.

8.3 Place the film being sampled on the glass cutting surface being cautious not to create wrinkles. Mark the machine direction (MD) of the sample. Do not touch the film test surface.

8.4 Align the paper sheets under and over the film in three locations equidistant across the film. Cut around the outside edges of the papers to form paper/film/paper sandwiches. Label the web location and side of the film that is to be on the outside of a wrapped load; this will be referred to as the "outside" surface and the other side the "inside" surface.

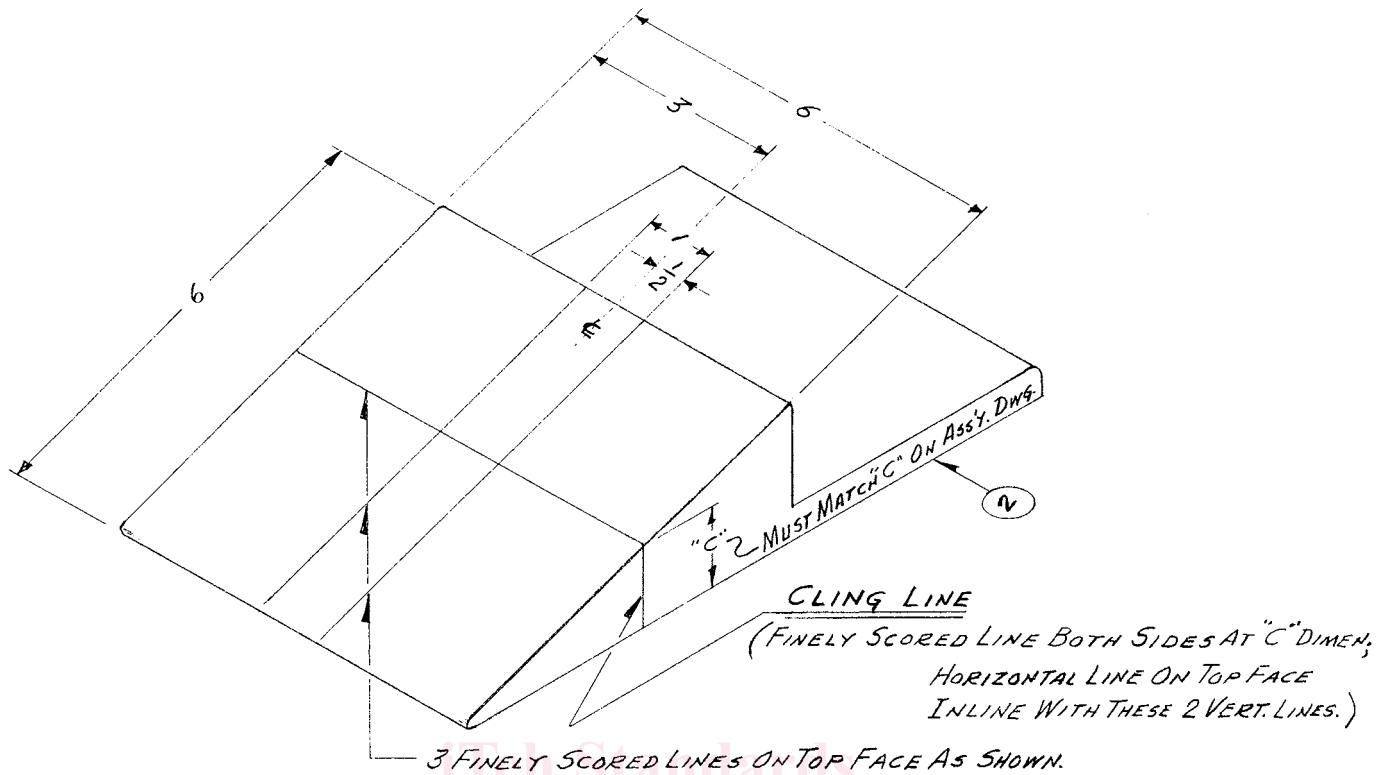

NOTE 1—1 in. = 25 mm.

FIG. 2 Incline Surface

8.5 Using the precision sample cutter, cut a 1 in. (25.4mm) transverse direction (TD) by approximately 7 in. (180 mm) machine direction (MD) specimen from each paper/film/paper sandwich. These will be used with the corresponding 5 by 20 in. (125 by 500 mm) samples.

8.6 Using the sample template and razor blade, cut three 5 by 7 in. (125 by 180 mm) TD by MD samples corresponding to the TD locations of the 1 by 7 in. (25.4 by 180 mm) samples cut in 8.5.

8.7 Perform subsequent testing "outside" surface to "inside" surface. Conduct testing within 30 min of sample preparation.

8.8 In the case of single-side cling film, or differential cling film, it may be necessary to also test outside to outside surface or inside to inside surface.

9. Conditioning

9.1 *Sample Conditioning*—Condition the test specimens at standard atmospheric condition for not less than 24 h prior to testing in accordance with Practice D4332.

9.2 *Test Conditions*—Conduct the test in accordance with the condition specified in 9.1.

10. Procedure

10.1 Loosen the fixture knob and push the incline up from the fixture surface. Allow the pins to hold the incline up. See Fig. 7 for a picture of test equipment and specimen set up for test.

10.2 Place a 5 by 20 in. (127 by 508 mm) sample squarely on the incline face with its outside surface up.

10.3 Tuck the film under the leading edge of the inclined bottom edge and reset the locating pins in their holes allowing the film to be clamped. Remove any obvious wrinkles and tighten the incline locking knob.

10.4 Grasp the unclamped corners of the film sample and pull back over the incline face to create a tight, smooth surface of film. A slight amount of stretching is acceptable. Do not touch the sample test area indicated by the lines on the incline face.

10.5 In accordance with the desired stretch percentage, measure down the incline face from the top and mark both edges of the film sample. The appropriate distances are as follows:

Desired Elongation, %	Distance Down Incline Face, in. (mm)
0	0 (0)
50	2 (50)
100	3 (75)
200	4 (100)

10.6 Roll the free end of the film up on the steel rod to within 1 in. (25 mm) of the marks on the film.

10.7 Elongate the sample, using the steel rod as the grip area, until the marks are aligned with the top edge of the incline.

10.8 While still holding the film tightly enough to maintain this extension, move the rod down and through the clamps and clamp the film. Some film might have to be allowed to unwind

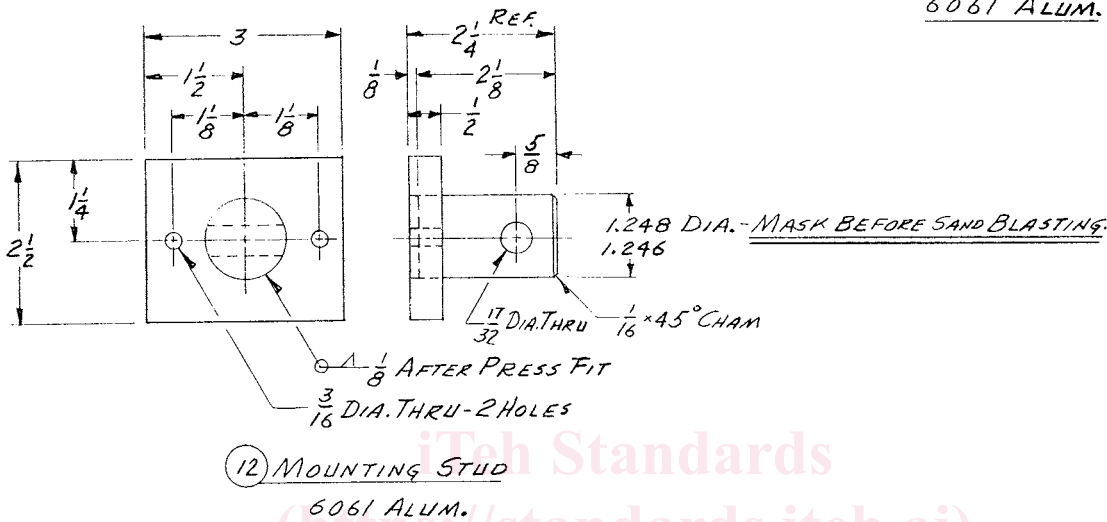
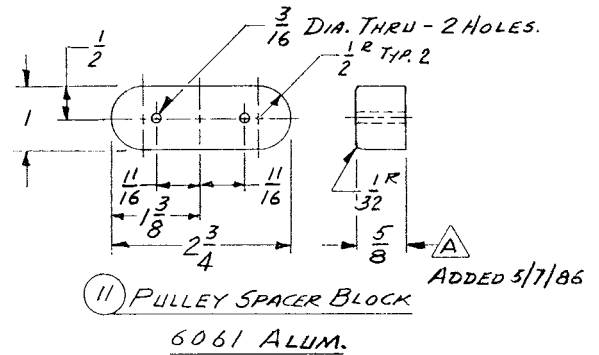
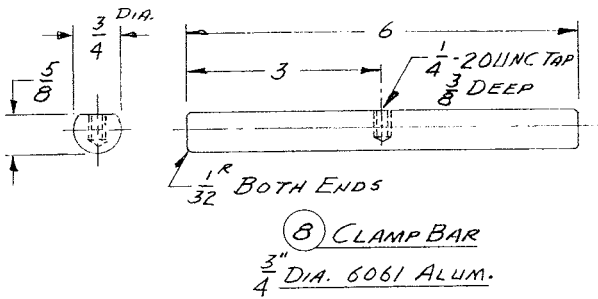

NOTE 1—1 in. = 25 mm.

FIG. 3 Mounting Stud

from the rod during this step to ensure proper mark positions and yet have film to clamp.

10.9 Take the corresponding 1 in. (25.4 mm) wide paper/film/paper sandwich sample and slide the paper to expose about 0.5 in. (12.5 mm) of film.

10.10 With the “outside” surface up, place this exposed film section on the incline film sample and at the top of the incline. Align it so that the remainder of the sample, with paper still in place, will lie between the parallel guide lines that run the full face length of the incline.

10.11 With the sample positioned properly, brush the exposed end down with moderate pressure. Grasp the opposite ends of the paper and gently pull the paper away from the film creating a smooth contact surface with the sample still properly aligned.

10.12 Using the wide side of the brush and moderate pressure and speed, brush the length of the 1 in. (25 mm) sample with three strokes. This will eliminate air and ensure good contact between the sample surfaces.

10.13 Roll the lower end of the 1 in. (25.4 mm) sample and insert it in the film clip.

10.14 Turn the chart and pen on and activate the crosshead.

10.15 At the moment when the 25.4-mm (1.0-in.) film specimen is separating from the incline at the horizontal cling line (see Fig. 1), mark the chart. This value is the cling force.

10.16 Turn the chart and pen off, return the crosshead, and remove the samples.

10.17 Repeat 10.1 to 10.16 for each replicate. A minimum of three replicates should be completed and the results averaged.

11. Report

11.1 Report the following information:

11.1.1 Any deviations from the procedure in Section 10, and

11.1.2 Sample identification (including nominal gage), % stretch, average cling value, and one standard deviation of the cling value. Cling values are reported in units of grams-force per inch width or Newtons/mm² (see Note 1).

NOTE 1—Although grams-force per inch width is recognized as the standard of the industry, grams is not a recognized force measurement. Newtons is a recognized force measurement. Conversion from gramsforce per inch to newtons per millimetre width can be made.

12. Precision and Bias

12.1 *Precision*—The following results are based on a round-robin experiment conducted in 1989, in accordance with Practice E691, involving seven materials tested by six laboratories. Each material was tested at two different stretch percentages, 100 and 200 %. Sample rolls of each material were provided to each participating laboratory, and that laboratory evaluated the material at each elongation five times to produce a final result.

12.1.1 The average cling for 100 % stretch among the seven samples was 0.078 N/mm. The standard deviation within each