



Designation: D 5731 – 07

Standard Test Method for Determination of the Point Load Strength Index of Rock and Application to Rock Strength Classifications¹

This standard is issued under the fixed designation D 5731; the number immediately following the designation indicates the year of original adoption or, in the case of revision, the year of last revision. A number in parentheses indicates the year of last reapproval. A superscript epsilon (ϵ) indicates an editorial change since the last revision or reapproval.

1. Scope*

1.1 This test method covers the guidelines, requirements, and procedures for determining the point load strength index of rock. This is an index test and is intended to be used to classify rock strength.

1.2 Specimens in the form of rock cores, blocks, or irregular lumps with a test diameter from 30 to 85 mm can be tested by this test method.

1.3 This test method can be performed in either the field or laboratory. The test is typically used in the field because the testing machine is portable, little or minimal specimen preparation is required, and specimens can be tested within a short time frame of being collected.

1.4 This test method applies to medium strength rock (compressive strength over 15 MPa (2200 psi)).

1.5 This test method does not cover which type of specimen should be tested or whether anisotropic factors should be considered. The specifics of the point load test program need to be developed prior to testing and possibly even before sampling. Such specifics would be dependent on the intended use of the data, as well as possible budgetary constraints and possible other factors, which are outside the scope of this test method.

1.6 All observed and calculated values shall conform to the guidelines for significant digits and rounding established in Practice D 6026.

1.7 The method used to specify how data are collected, calculated, or recorded in this standard is not directly related to the accuracy to which the data can be applied in design or other uses, or both. How one applies the results obtained using this standard is beyond its scope.

1.8 The values stated in the SI units are to be regarded as standard.

1.9 *This standard does not purport to address all of the safety concerns, if any, associated with its use. It is the responsibility of the user of this standard to establish appropriate safety and health practices and determine the applicability of regulatory limitations prior to use.*

¹ This test method is under the jurisdiction of ASTM Committee D18 on Soil and Rock and is the direct responsibility of Subcommittee D18.12 on Rock Mechanics. Current edition approved Feb. 1, 2007. Published April 2007. Originally approved in 1995. Last previous edition approved in 2005 as D 5731–05.

2. Referenced Documents

2.1 *ASTM Standards:*²

D 653 Terminology Relating to Soil, Rock, and Contained Fluids

D 2216 Test Methods for Laboratory Determination of Water (Moisture) Content of Soil and Rock by Mass

D 3740 Practice for Minimum Requirements for Agencies Engaged in the Testing and/or Inspection of Soil and Rock as Used in Engineering Design and Construction

D 5079 Practices for Preserving and Transporting Rock Core Samples

D 6026 Practice for Using Significant Digits in Geotechnical Data

D 7012 Test Method for Compressive Strength and Elastic Moduli of Intact Rock Core Specimens under Varying States of Stress and Temperatures

E 18 Test Methods for Rockwell Hardness of Metallic Materials

E 122 Practice for Calculating Sample Size to Estimate, With Specified Precision, the Average for a Characteristic of a Lot or Process

2.2 *ISRM Standard:*

Suggested Methods for Determining Point Load Strength³

3. Terminology

3.1 For definitions of terms used in this test method refer to Terminology D 653.

3.2 *Definitions of Terms Specific to This Standard:*

3.2.1 *diameter*— D , for point load tests, the dimension of the specimen between the opposing conical, test platens when placed in the test machine

3.2.2 *point load strength anisotropy index*— $I_{a(D)}$, the strength anisotropy index is defined as the ratio of mean $I_{s(D)}$ values measured perpendicular and parallel to planes of weakness, that is, the ratio of greatest to least point load strength

² For referenced ASTM standards, visit the ASTM website, www.astm.org, or contact ASTM Customer Service at service@astm.org. For *Annual Book of ASTM Standards* volume information, refer to the standard's Document Summary page on the ASTM website.

³ "Suggested Methods for Determining Point Load Strength", International Society for Rock Mechanics Commission on Testing Methods, *Int. J. Rock. Mech. Min. Sci. and Geomechanical Abstr.*, Vol 22, No. 2, 1985, pp. 51–60.

*A Summary of Changes section appears at the end of this standard.

indices on different axes that result in the greatest and least ratio of point load strengths values.

3.2.3 *size-corrected point load strength index*— $I_s (D)$, the original point load strength index value multiplied by a factor to normalize the value that would have been obtained with diametral test of diameter (D).

3.2.4 *uncorrected point load strength index*—(I_s), an indicator of strength (see 10.1) obtained by subjecting a rock specimen to an increasingly concentrated point load, applied through a pair of truncated, conical platens, until failure occurs.³

4. Summary of Test Method

4.1 This index test is performed by subjecting a rock specimen to an increasingly concentrated load until failure occurs by splitting the specimen. The concentrated load is applied through coaxial, truncated conical platens. The failure load is used to calculate the point load strength index.

4.2 The point load strength index can be used to classify the rocks. A common method used is by estimating the uniaxial compressive strength.

5. Significance and Use

5.1 The uniaxial compression test (see Test Method D 7012) is used to determine compressive strength of rock specimens. However, it is a time-consuming and expensive test that requires significant specimen preparation and the results may not be available for a long time after the samples are collected. When extensive testing and/or timely information is required for preliminary and reconnaissance information, alternative tests such as the point load test can be used to reduce the time and cost of compressive strength tests, when used in the field. Such data can be used to make timely and more informed decisions during the exploration phases and more efficient and cost effective selection of samples for more precise and expensive laboratory tests.

5.2 The point load strength test is used as an index test for strength classification of rock materials. The test results should not be used for design or analytical purposes.

5.3 This test method is performed to determine the point load strength index of rock specimens and, if required, the point load strength anisotropy index.

5.4 Rock specimens in the form of either core (the diametral and axial tests), cut blocks (the block test), or irregular lumps (the irregular lump test) are tested by application of concentrated load through a pair of truncated, conical platens. Little or no specimen preparation is required and can therefore be tested shortly after being obtained and any influence of moisture condition on the test data minimized. However, the results can be highly influenced by how the specimen is treated from the time it is obtained until the time it is tested. Therefore, it may be necessary to handle specimens in accordance with Practice D 5079 and to document moisture conditions in some manner in the data collection.

NOTE 1—The quality of the result produced by this standard is dependent upon the competence of the personnel performing it, and the suitability of the equipment and facilities used. Agencies that meet the criteria of Practice D 3740 are generally considered capable of competent and objective testing and sampling. Users of this standard are cautioned

that compliance with Practice D 3740 does not in itself assure reliable results. Reliable results depend on many factors; Practice D 3740 provides a means of evaluating some of those factors.

6. Apparatus

6.1 *General*—A basic point load tester (see Fig. 1) consists of a loading system typically comprised of a loading frame, platens, a measuring system for indicating load, P , (required to break the specimen), and a means for measuring the distance, D , between the two platen contact points at the start of testing and after failure. The equipment shall be resistant to shock and vibration so that the accuracy of readings is not adversely affected by repeated testing. Any special operational, maintenance or calibrations instructions provided by the manufacturer for the particular apparatus being used shall be followed.

6.2 Loading System:

6.2.1 The loading system shall have a loading frame with a platen-to-platen clearance that allows testing of rock specimens in the required size range. Typically, this range is between 30 to 100 mm, or the maximum opening size of the load frame, so that an adjustable distance is available to accommodate both small and large specimens.

NOTE 2—It is generally accepted that specimens smaller than 42 mm (BX cores) are not recommended because for smaller diameters the loading points can not be considered as theoretical “points” in relation to specimen size.⁴

6.2.2 The loading capacity shall be sufficient to break the largest and strongest specimens to be tested. Point load strength of rock is usually an order of magnitude lower than the compressive strength of rock.

6.2.3 The load frame shall be designed and constructed so that it does not permanently distort during repeated applications of the maximum test load, and so that the platens remain coaxial within ± 0.2 mm throughout testing. No spherical seat or other nonrigid component is permitted in the loading system. Loading system rigidity is essential to avoid slippage when specimens of irregular geometry are tested.

6.2.4 Truncated, conical platens, as shown on Fig. 2, are to be used. The 60° cone and 5-mm radius spherical platen tip shall meet tangentially. The platens shall be of hard material (Rockwell 58 HRC, as explained in Test Method E 18) such as tungsten carbide or hardened steel so they remain undamaged during testing.

6.3 Load Measuring System:

6.3.1 A load measuring system, for example a load cell or a hydraulic pressure gage, that will indicate failure load, P , required to break specimen. The system should conform to the requirements of 6.3.2-6.3.4.

6.3.2 Measurements of failure load, P , shall be to a precision of $\pm 5\%$ or better of full-scale load-measuring system, irrespective of the size and strength of specimen that is tested.

6.3.3 Failure is often sudden, therefore, and a peak load indicator is required so the failure load can be recorded after each test.

⁴ Bieniawski, Z.T., The Point Load Test in Geotechnical Practice, Engineering Geology (9), pages 1-11, 1975.

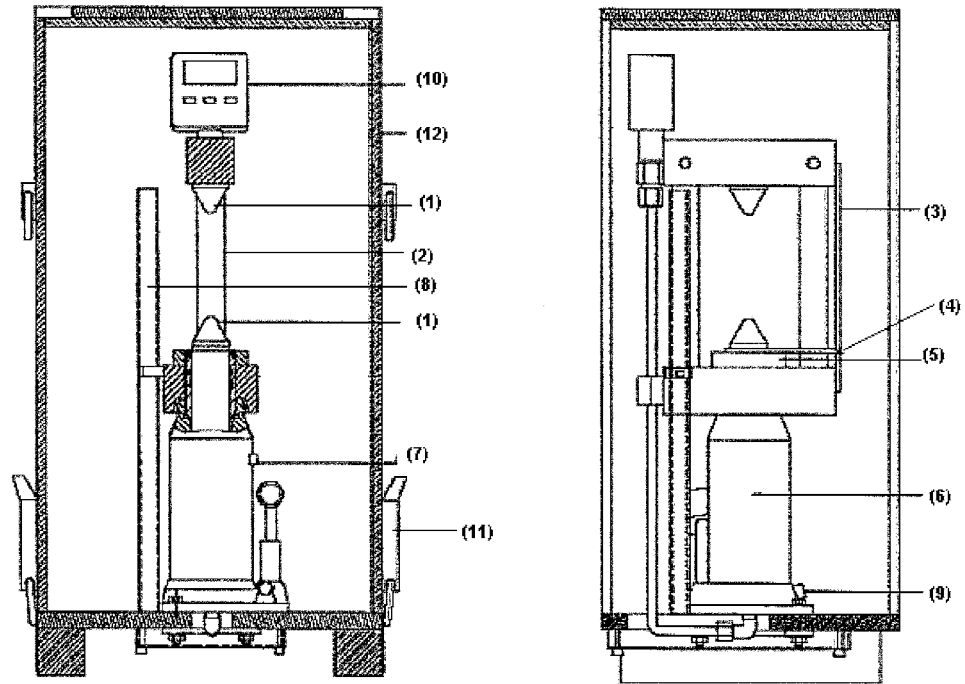

NOTE—Load frame general information (figure 1) Load is applied to the specimens through two standard hardened points (1) Two column fixed crosshead frame (2) Scale (3) Scale pointer (4) Attached by a bolt (5) to the hydraulic pump body (6) Oil filler cap (7) The hydraulic piston assembly incorporated the oil reservoir, a single acting pump, pressure relief valve (9), and a handle (8) Pump handle (8) Pressure release valve (9) Case latched for top cover (10) Digital pressure readout (11) Point load tester top cover (12)

FIG. 1 Example of a Light-Weight Point Load Test Apparatus

6.3.4 If required, the system should be capable of using interchangeable, mechanical or electronic gauge, load measuring devices in order to be consistent with the estimated strength of rock and have the desired reading accuracy.

6.4 Distance Measuring System:

6.4.1 The distance measuring system, an electronic or vernier direct reading scale, should connect to the loading frame for measuring the distance, *D*, between specimen-platen contact points at the start of testing and just prior to failure and conform to requirements 6.4.2 and 6.4.3.

6.4.2 Measurements of *D* shall be to an accuracy of $\pm 2\%$ or better of distance between contact points, irrespective of the size and strength of specimen that is tested.

6.4.3 The measuring system shall allow a check of the “zero displacement” value when the two platens are in contact and should include a zero adjustment and a means to record or measure any penetration of the specimen by the point load platens during testing.

6.4.4 An instrument such as a caliper or a steel rule is required to measure the width, *W*, (with an accuracy of $\pm 5\%$) of specimens for all but the diametral test.

6.5 Miscellaneous Items—Depending on the type of samples (core or non core) and the type of specimens to be tested (diametral, Block, Axial, etc.), the following items may be needed: diamond saw, chisels, towels, marking pens, and plotting paper.

7. Test Samples

7.1 Rock samples are grouped on the basis of rock type, test direction if rock is anisotropic, and estimated strength.

7.2 Sample Size

7.2.1 When testing core or block samples at least ten specimens are selected for the samples.

7.2.2 When testing irregular-shaped specimens obtained by other means at least 20 specimens are selected for the samples.

7.2.3 Sample sizes may need to be larger if the rock is anisotropic or heterogeneous.

7.2.4 If needed, Practice E 122 can be used to more precisely determine the sample size.

7.3 Samples in the form of core are preferred for a more precise classification.

7.4 For anisotropic rocks the best results for core samples is when the core axis is perpendicular to the plane of weakness.

8. Test Specimens

8.1 Test Diameter—The specimen’s external test diameter shall not be less than 30 mm and not more than 85 mm with the preferred test diameter of about 50 mm.

8.2 Size and Shape—The size and shape requirements for diametral, axial, block, or irregular lump testing shall conform with the recommendations shown on Fig. 3. The sides of the specimens shall be free from abrupt irregularities that can

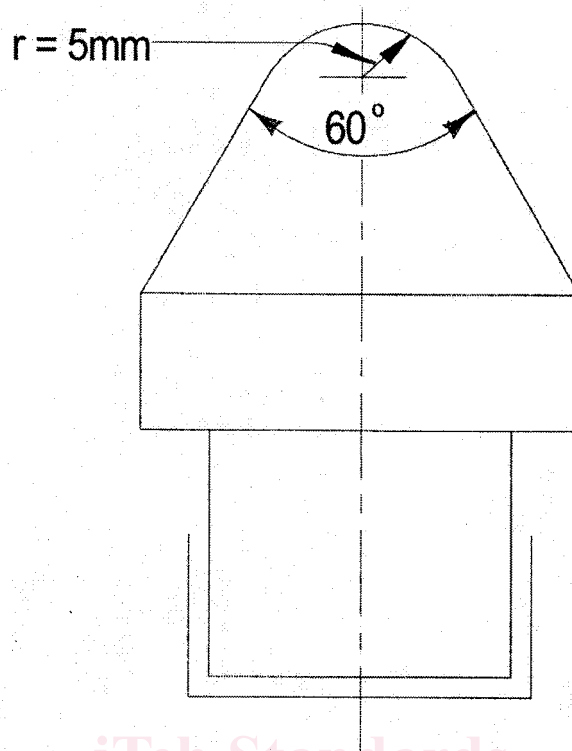
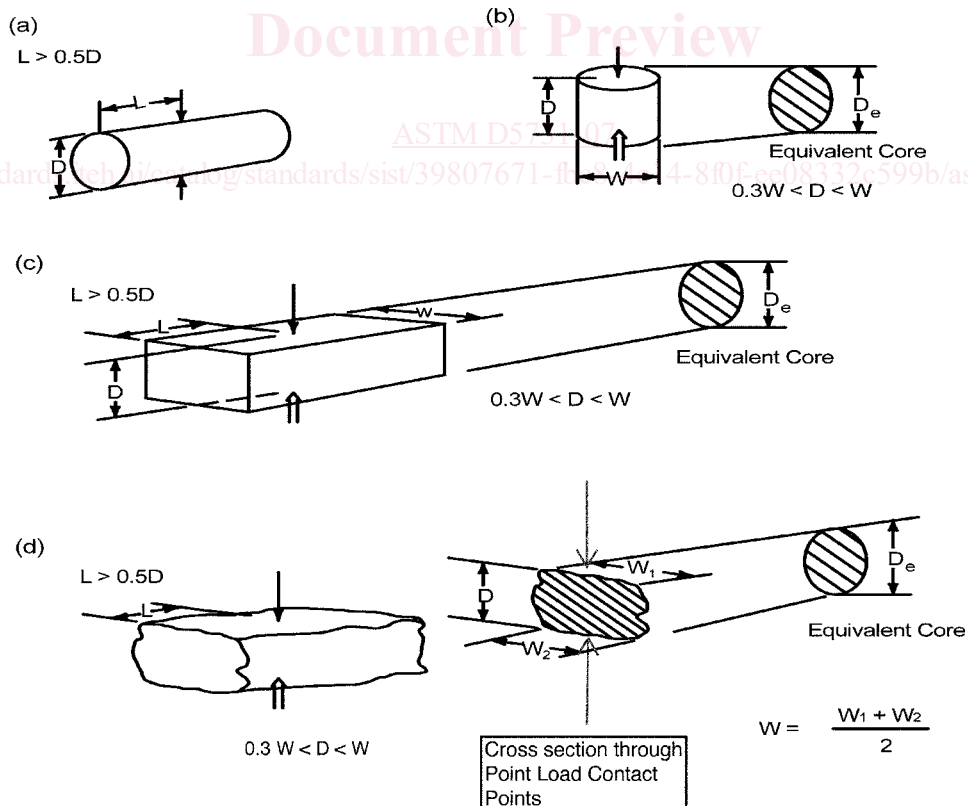

FIG. 2 Truncated, Conical Platen Dimensions for Point Load Apparatus



NOTE 1—Legend: L = distance between contact points and nearest free face, and D_e = equivalent core diameter (see 10.1).

FIG. 3 Load Configurations and Specimen Shape Requirement for (a) the Diametral Test, (b) the Axial Test, (c) the Block Test, and (d) the Irregular Lump Test³

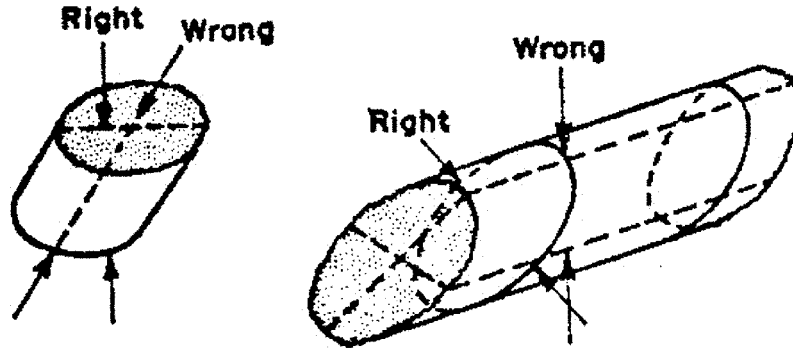

FIG. 4 Anisotropy measurements and testing for maximum and minimum indices

generate stress concentrations. No specimen preparation is required, however a rock saw or chisels may be required for block or irregular specimens. Proper planning of diametral tests on rock cores can produce suitable lengths of core for subsequent axial testing provided they are not weakened by the diametral test. Otherwise, suitable specimens can be obtained from the cores by saw-cutting, or core splitting.

NOTE 3—While there are no established specimen guidelines for grain size versus specimen size this subject is still important and must be included in the testing and use of the data. Concrete testing using a point load tester recommends that a minimum ratio of core diameter to maximum aggregate size of 4 be used.⁵ This ratio may be used until guidelines are developed for rock.

8.3 *Water Content*—Water content of the specimen can affect the value of the point load strength. Therefore, the testing plan shall include how water content will be included in the point load testing program. This may include the recording, controlling, and measurement of water content.

8.4 *Marking and Measuring Specimens*—The specimens shall be properly marked and measured as shown in Fig. 4.

8.4.1 *Marking*—The desired test orientation of the specimen shall be indicated by marking lines on the specimen. These lines are used for centering the specimen in the testing machine, and to ensure proper orientation during testing, including any issues involving anisotropic rocks (see Fig. 3). These lines may also be used as reference lines for measuring width, length, and diameter.

8.4.2 *Measuring*—Measure each dimension of a specimen at three different places, and calculate the averages.

9. Procedure

9.1 Develop a testing plan and, if needed, sampling plan to provide specimens for point load testing according to the following procedures for the specific specimen shape (diametral, axial, block or irregular).

9.2 Diametral Test

9.2.1 Core specimens with length/diameter ratio greater than one are suitable for diametral testing.

9.2.2 Insert a specimen in the test device and close the platens to make contact along a core diameter. Ensure that the

distance, L , between the contact points and the nearest free end is at least 0.5 times the core diameter (see Fig. 3 and Fig. 4(a)).

9.2.3 Determine and record the distances D and L (see Fig. 3).

9.2.4 Steadily increase the load such that failure occurs within 10 to 60 s, and record failure load, P . The test should be rejected if the fracture surface passes through only one platen loading point (see Fig. 5(d)).

9.2.5 The procedures in 9.2.2-9.2.4 are repeated for each specimen of the rock type.

9.3 Axial Test

9.3.1 Core specimens with length/diameter ratio of $\frac{1}{3}$ to 1 are suitable for axial testing (see Fig. 3(b)). Suitable specimens can be obtained by saw-cutting or chisel-splitting the core sample, or by using suitable pieces produced by carefully planned diametral tests (see 9.2).

9.3.2 Insert a specimen in the test machine and close the platens to make contact along a line perpendicular to the core end faces (in the case of isotropic rock, the core axis, but see Fig. 5 and 9.5 for anisotropic rock).

9.3.3 Record the distance, D , between platen contact points (see Fig. 3). Record the specimen width, W , perpendicular to the loading direction, with an accuracy of $\pm 5\%$.

9.3.4 Steadily increase the load such that failure occurs within 10 to 60 s, and record the failure load, P . The test should be rejected if the fracture surface passes through only one loading point (see Fig. 6(e)).

9.3.5 Procedures 9.3.2-9.3.4 are repeated for each test specimen of the rock type.

9.4 Block and Irregular Lump Tests:

9.4.1 Rock blocks or lumps, 30 to 85 mm, and of the shape shown in Fig. 3(c) and (d) are suitable for the block and the irregular lump tests. The ratio, D/W , should be between $\frac{1}{3}$ and 1, preferably close to 1. The distance L should be at least 0.5 W . Suitable specimens can be obtained by saw-cutting or chisel-splitting larger samples or specimens if needed.

9.4.2 Insert a specimen in the testing machine and close the platens to make contact with the smallest dimension of the lump or block, away from edges and corners (see Fig. 3(c) and (d)).

9.4.3 Record the distance D between platen contact points. Record the smallest specimen width, W , perpendicular to the loading direction. If the sides are not parallel, then calculate W

⁵ Robins, P.J., The Point Load Strength Test for Concrete Cores, Magazine of Concrete Research, Vol. 32, No. 111, June 1980.

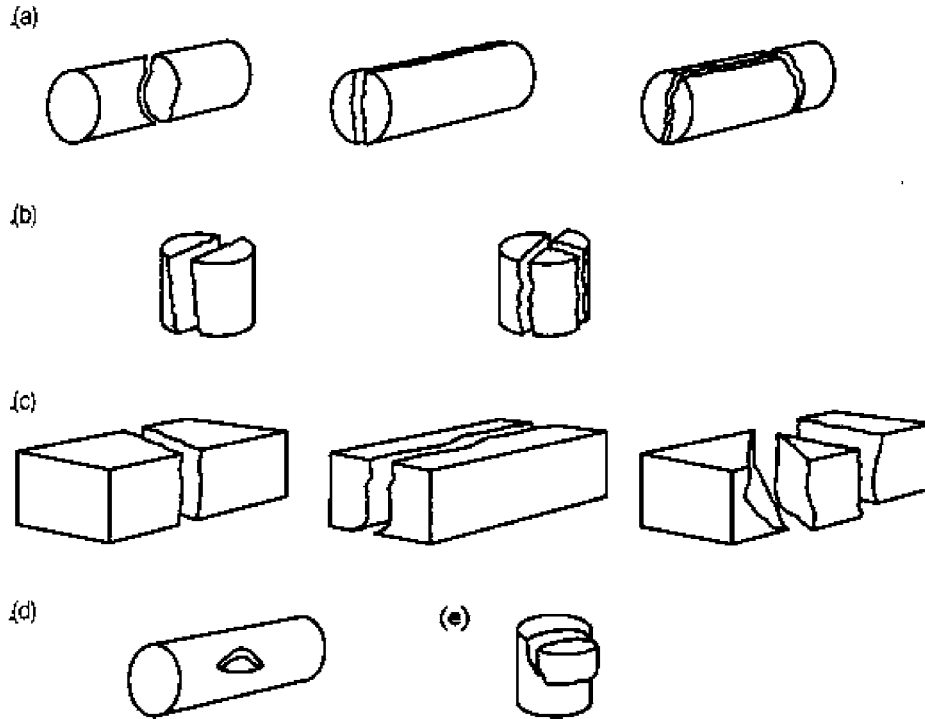

FIG. 5 Typical Modes of Failure for Valid and Invalid Tests—(a) Valid diametral tests; (b) valid axial tests; (c) valid block tests; (d) invalid core test; and (e) invalid axial test (point load strength index test).⁵

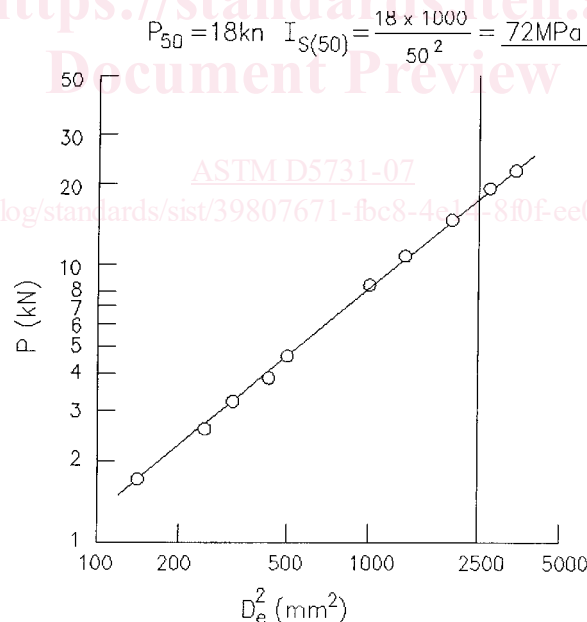

FIG. 6 Procedure for Graphical Determination of $I_{s(50)}$ from a Set of Results at D_e Values Other Than 50 mm⁶

as $(W_1 + W_2)/2$ as shown on Fig. 3. This width, W , is used in calculating point load strength index irrespective of the actual mode of failure (see Fig. 5 (c)).

9.4.4 Steadily increase the load such that failure occurs within 10 to 60 s, and record the failure load, P . The test should be rejected if the fracture surface passes through only one loading point (see examples for other shapes in Fig. 5(d) or (e)).

9.4.5 Procedures 9.4.2-9.4.4 are repeated for each test specimen in the sample.

9.5 Anisotropic Rock:

9.5.1 When a rock sample is shaly, bedded, schistose, or otherwise observably anisotropic, it should be tested in directions that will give the greatest and least strength values, in general, parallel and normal to the planes of anisotropy.