



Standard Practice for Heat Fusion Joining of Polyolefin Pipe and Fittings¹

This standard is issued under the fixed designation D2657; the number immediately following the designation indicates the year of original adoption or, in the case of revision, the year of last revision. A number in parentheses indicates the year of last reapproval. A superscript epsilon (ϵ) indicates an editorial change since the last revision or reapproval.

This standard has been approved for use by agencies of the U.S. Department of Defense.

1. Scope

1.1 This practice describes general procedures for making joints with polyolefin pipe and fittings (excluding polyethylene pipe and fittings) by means of heat fusion joining techniques in either a shop or field environment. These procedures are general ones. Specific instructions for heat fusion joining are obtained from product manufacturers. See Practice **F2620** for heat fusion joining of polyethylene pipe and fittings.

1.2 The techniques covered are applicable only to joining polyolefin pipe and fittings of related polymer chemistry, for example, polypropylenes to polypropylenes, or polybutylenes to polybutylenes. Material, density, and flow rate shall be taken into consideration in order to develop uniform melt viscosities and formation of a good fusion bond when joining the same material to itself or to other materials of related polymer chemistry.

1.3 Parts that are within the dimensional tolerances given in present ASTM specifications are required to produce sound joints between polyolefin pipe and fittings when using the joining techniques described in this practice.

1.4 The values stated in inch-pound units are to be regarded as the standard. The values given in parentheses are for information only.

1.5 The text of this practice references notes, footnotes, and appendixes which provide explanatory material. These notes and footnotes (excluding those in tables and figures) shall not be considered as requirements of the practice.

1.6 *This standard does not purport to address all of the safety concerns, if any, associated with its use. It is the responsibility of the user of this standard to establish appropriate safety and health practices and determine the applicability of regulatory limitations prior to use. See specific safety precautions in 3.1.1, 5.2, 8.2.3.1, Note 8 and Note 9, and A1.1.*

2. Referenced Documents

2.1 ASTM Standards:²

F1056 Specification for Socket Fusion Tools for Use in Socket Fusion Joining Polyethylene Pipe or Tubing and Fittings

F2620 Practice for Heat Fusion Joining of Polyethylene Pipe and Fittings

3. Summary of Practice

3.1 Heat-fusion joining uses a combination of heat and force resulting in two melted surfaces flowing together to produce a joint. Fusion bonding occurs when the joint cools below the melt temperature of the material. There is a temperature range within which any particular material is satisfactorily joined. The specific temperature used requires consideration of the properties of the specific material, and the joining environment. With Techniques II or III (3.3.2 or 3.3.3), there is also an appropriate force to be applied which depends upon the material, the fusion equipment being used, and fusion temperature. See Practice **F2620** for heat fusion procedure for polyethylene pipe and fittings.

3.1.1 Electrically powered heat fusion tools and equipment are usually not explosion proof. When performing heat fusion in a potentially combustible atmosphere such as in an excavation where gas is present, all electrically powered tools and equipment that will be used in the combustible atmosphere shall be disconnected from the electrical power source and operated manually to prevent explosion and fire. For the heating tool, this requires bringing the heating tool up to or slightly above temperature in a safe area, then disconnecting it from electrical power immediately before use. This procedure is limited to smaller sizes where heating is accomplished before the heating tool drops below acceptable temperature.

3.2 Adequate joint strength for testing is attained when all of the joint material cools to ambient temperature. The joint shall not be disturbed or moved until it has cooled. See Practice **F2620** for heat fusion procedure for polyethylene pipe and fittings.

¹ This practice is under the jurisdiction of ASTM Committee **F17** on Plastic Piping Systems and is the direct responsibility of Subcommittee **F17.20** on Joining.

Current edition approved May 1, 2007. Published May 2007. Originally approved in 1967. Last previous edition approved in 2003 as D2657 – 03. DOI: 10.1520/D2657-07.

² For referenced ASTM standards, visit the ASTM website, www.astm.org, or contact ASTM Customer Service at service@astm.org. For *Annual Book of ASTM Standards* volume information, refer to the standard's Document Summary page on the ASTM website.

NOTE 1—Polybutylene undergoes a crystalline transformation for several days after cooling below its melt temperature. Although this phenomenon has an effect on the ultimate physical properties of the material, its effect on testing of joints has not been found to be significant. If there is any question of its effect, a comparison should be made between joints that have been conditioned for different periods of time in order to establish the conditioning-time relationship.

3.3 Three fusion techniques are covered in this practice as follows: See Practice F2620 for heat fusion procedure for polyethylene pipe and fittings.

3.3.1 *Procedure 1, Socket Fusion*—The socket-fusion technique involves simultaneously heating the outside surface of a pipe end and the inside of a fitting socket, which is sized to be smaller than the smallest outside diameter of the pipe. After the proper melt has been generated at each face to be mated, the two components are joined by inserting one component into the other. See Fig. 1. The fusion bond is formed at the interface resulting from the interference fit. The melts from the two components flow together and fuse as the joint cools. Optional alignment devices are used to hold the pipe and socket fitting in Logitudinal alignment during the joining process; especially with pipe sizes 3 in. IPS (89 mm) and larger.

3.3.2 *Procedure 2, Butt Fusion*—The butt-fusion technique in its simplest form consists of heating the squared ends of two pipes, a pipe and a fitting, or two fittings, by holding them against a heated plate, removing the plate when the proper melt is obtained, promptly bringing the ends together, and allowing the joint to cool while maintaining the appropriate applied force. See Fig. 2. An alignment jig shall be used to obtain and maintain suitable alignment of the ends during the fusion operation.

3.3.3 *Procedure 3, Saddle Fusion*—The saddle-fusion technique involves melting the concave surface of the base of a saddle fitting, while simultaneously melting a matching pattern on the surface of the pipe, bringing the two melted surfaces

together and allowing the joint to cool while maintaining the appropriate applied force. See Fig. 3.

4. Significance and Use

4.1 The procedures described in Sections 7, 8, and 9, when implemented using suitable equipment and procedures in either a shop or field environment, produce strong pressure-tight joints equal to the strength of the piping material. Some materials are more adaptable to one technique than another. Melt characteristics, average molecular weight and molecular weight distribution are influential factors in establishing suitable fusion parameters; therefore, consider the manufacturer's instructions in the use or development of a specific fusion procedure.

5. Operator Experience

5.1 Skill and knowledge on the part of the operator are required to obtain a good quality joint. This skill and knowledge is obtained by making joints in accordance with proven procedures under the guidance of skilled operators. Evaluate operator proficiency by testing sample joints.

5.2 The party responsible for the joining of polyolefin pipe and fittings shall ensure that detailed procedures developed in conjunction with applicable codes and regulations and the manufacturers of the pipe, fittings, and joining equipment involved, including the safety precautions to be followed, are issued before actual joining operations begin.

6. Apparatus: General Recommendations

6.1 *Heating Tool*—The tool may be heated by gas or electricity. Gas-fired heaters for 2in. IPS and smaller socket and butt fusion joints only, shall have heat sinks of sufficient capacity to prevent excessive draw down of the tool

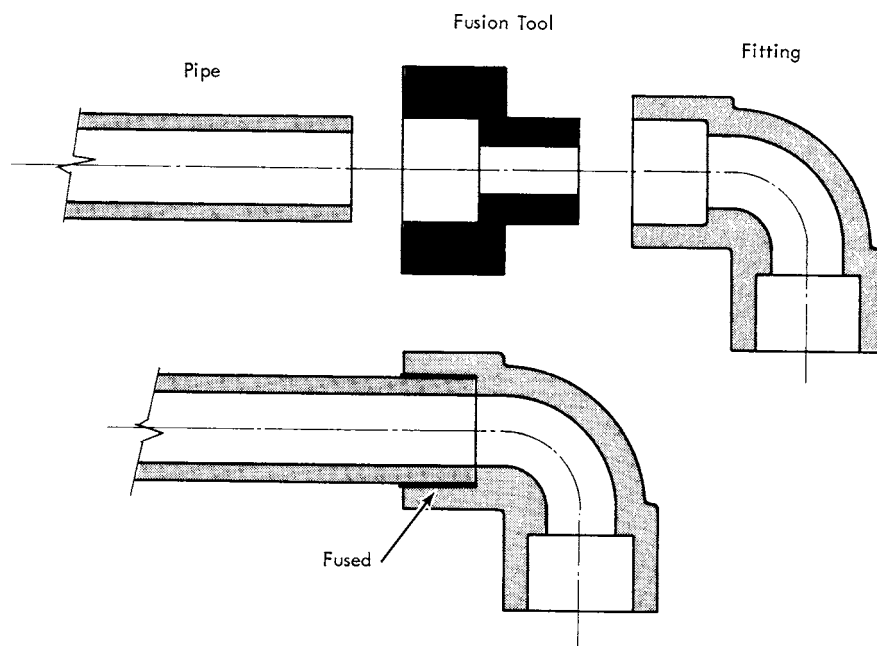

FIG. 1 Socket Fusion

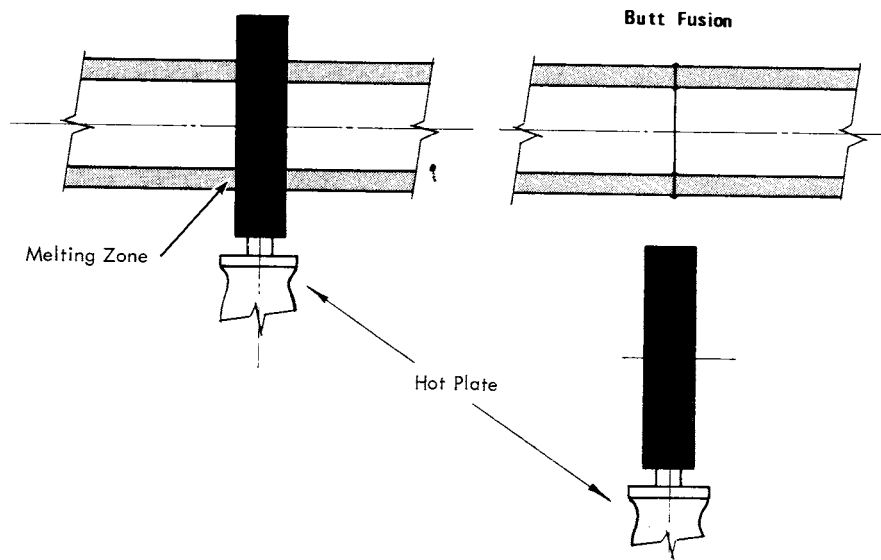

FIG. 2 Typical Butt Fusion Operation

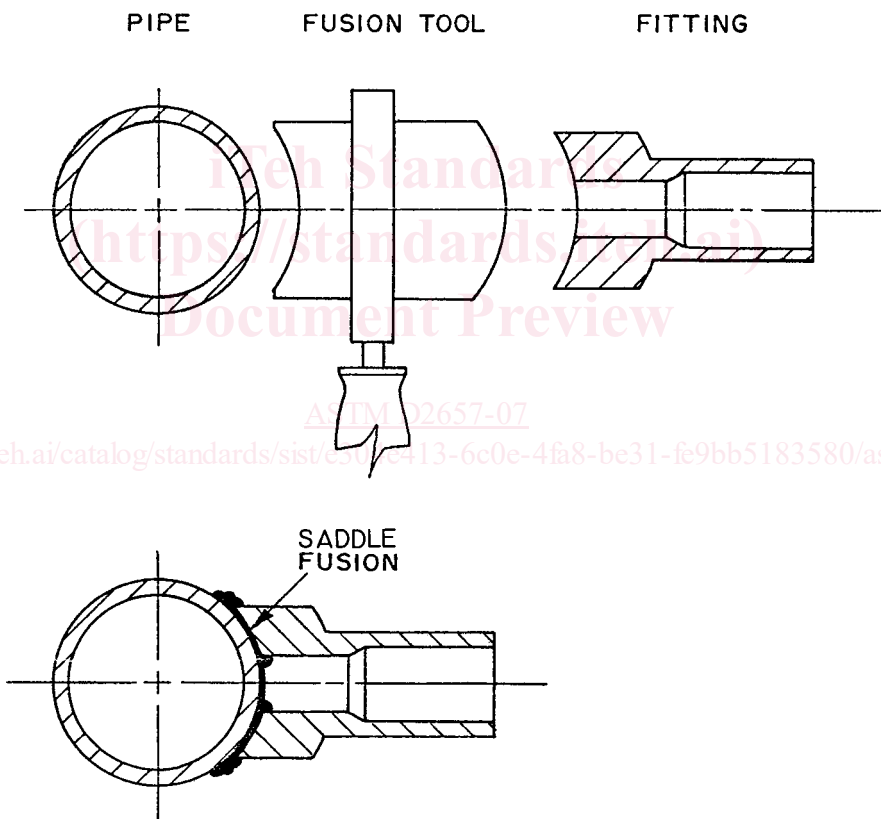

FIG. 3 Saddle Fusion

temperature, and are used only in above-freezing conditions. Electric heating plates maintain consistent fusion temperatures when provided with an adequate power source. Electric heating plates for general fusion use shall be controlled thermostatically and most are adjustable for a set point temperature ranging from 300 to 575°F (150 to 300°C). Some tools may have a fixed set point for a particular application.

6.2 *Heating Tool Faces*—Heating tools may be made from materials such as aluminum, stainless steel, copper, or copper

alloys. Copper or copper-alloy heating faces are not suitable, unless chromium-plated or clad with another suitable metal, because some polyolefins react with copper. Plastic materials may stick to hot metal heating surfaces. This sticking may be minimized by applying a non-stick coating to the heating surfaces or by fitting a high-temperature, non-stick fabric over the heating surfaces. The heating plate surfaces, coated or uncoated, shall be kept clean and free of contaminants such as dirt, grease and plastic build-up, which may cause excessive