



Designation: F703 – 07

Standard Specification for Implantable Breast Prostheses¹

This standard is issued under the fixed designation F703; the number immediately following the designation indicates the year of original adoption or, in the case of revision, the year of last revision. A number in parentheses indicates the year of last reappraisal. A superscript epsilon (ϵ) indicates an editorial change since the last revision or reappraisal.

1. Scope

1.1 This specification covers the requirements for silicone gel-filled and saline-inflatable silicone gel-filled implantable breast prostheses intended for use in surgical reconstruction, augmentation, or replacement of the breast.

1.2 *Limitations*—This specification does not cover custom fabricated implantable breast prostheses.

1.3 Single-use saline-inflatable, smooth, and textured silicone shell implantable breast prostheses are addressed in Specification [F2051](#).

1.4 The values stated in SI units are to be regarded as the standard. The inch-pound units given in parentheses are for information only.

1.5 *This standard does not purport to address all of the safety concerns, if any, associated with its use. It is the responsibility of the user of this standard to establish appropriate safety and health practices and determine the applicability of regulatory limitations prior to use.*

2. Referenced Documents

2.1 *ASTM Standards*:²

[D412](#) Test Methods for Vulcanized Rubber and Thermoplastic Elastomers—Tension

[D1349](#) Practice for Rubber—Standard Conditions for Testing

[F748](#) Practice for Selecting Generic Biological Test Methods for Materials and Devices

[F1251](#) Terminology Relating to Polymeric Biomaterials in Medical and Surgical Devices (Withdrawn 2012)³

[F2038](#) Guide for Silicone Elastomers, Gels, and Foams Used in Medical Applications Part I—Formulations and Uncured Materials

¹ This specification is under the jurisdiction of ASTM Committee F04 on Medical and Surgical Materials and Devices and is the direct responsibility of Subcommittee F04.32 on Plastic and Reconstructive Surgery.

Current edition approved April 1, 2007. Published May 2007. Originally approved in 1981. Last previous edition approved in 2002 as F703 – 96 (2002) ^{ϵ 1}. DOI: 10.1520/F0703-07.

² For referenced ASTM standards, visit the ASTM website, www.astm.org, or contact ASTM Customer Service at service@astm.org. For *Annual Book of ASTM Standards* volume information, refer to the standard's Document Summary page on the ASTM website.

³ The last approved version of this historical standard is referenced on www.astm.org.

[F2042](#) Guide for Silicone Elastomers, Gels, and Foams Used in Medical Applications Part II—Crosslinking and Fabrication

[F2051](#) Specification for Implantable Saline Filled Breast Prosthesis

2.2 *Other Documents*:

[Saline, Silicone Gel, and Alternative Breast Implants—Guidance for Industry and FDA Staff, November 17, 2006](#)⁴

[ISO/AAMI/ANSI 10993-1 Biological Evaluation of Medical Devices—Part 1: Evaluation and Testing](#)⁵

3. Terminology

3.1 *Definitions*:

3.1.1 *barrier coat, n*—a silicone elastomer layer that is part of the shell of a silicone gel implantable breast prosthesis that retards silicone bleed.

3.1.2 *fixation site, n*—an area of the shell of an implantable breast prosthesis containing material that allows tissue ingrowth.

3.1.3 *fused or adhered joints (seams), n*—sites in the shell or other parts of an implantable breast prosthesis where materials have been joined (fused or bonded) together, with or without an adhesive, as part of the manufacturing process.

3.1.4 *gel bleed, n*—diffusion of liquid silicone components of silicone gel through the shell of an implantable breast prosthesis.

3.1.5 *gel-filled breast prosthesis, n*—implantable breast prosthesis designed and provided with a pre-filled, fixed volume of silicone gel.

3.1.5.1 *Type I breast prosthesis, n*—implantable breast prosthesis containing a single lumen containing a fixed amount of silicone gel.

(1) *Discussion*—The lumen of a Type I breast prostheses is not accessible for volume adjustments of any kind.

3.1.5.2 *Type II breast prosthesis, n*—implantable breast prosthesis comprised of two complete lumens, one inside the other.

⁴ Available from U.S. Department of Health and Human Services, Food and Drug Administration (FDA), 5600 Fishers Ln., Rockville, MD 20857, <http://www.fda.gov/cdrh/ode/guidance/1239>.

⁵ Available from American National Standards Institute (ANSI), 25 W. 43rd St., 4th Floor, New York, NY 10036, <http://www.ansi.org>.

(I) *Discussion*—The inner lumen of a Type II implantable breast prosthesis contains a fixed amount of silicone gel and is not accessible for volume adjustments of any kind. The outer lumen is provided with a valve to facilitate filling the void between the inner and outer lumens with saline to adjust the total volume of the prosthesis, at the time of use. The valve system may also be designed to facilitate post-operative saline volume adjustment by following the instructions provided in the product literature.

3.1.5.3 *Type III breast prosthesis, n*—implantable breast prosthesis comprised of two complete lumens, one inside the other.

(I) *Discussion*—The area between the inner and outer lumens contains a fixed amount of silicone gel and is not accessible for volume adjustments of any kind. The inner lumen is contained within the silicone gel contained in the outer lumen and has a valve system to facilitate filling the inner lumen with saline to increase the volume of the prosthesis at the time of use. The valve system may also be designed to facilitate post-operative saline volume adjustment by following the instructions provided in product literature.

3.1.6 *low bleed, n*—silicone gel implantable breast prostheses designed to have minimal silicone bleed when tested using the test method in 9.2.1.

3.1.7 *lumen, n*—a cavity within a shell of an implantable breast prosthesis.

3.1.7.1 *Discussion*—A lumen may contain either a fixed, non-adjustable volume of silicone gel, or it may be entirely or partly empty and intended to be inflated (filled) with saline. Inflatable lumens are accessible by valve to facilitate the addition of saline to adjust the volume of the prosthesis at the time of use. More than one lumen may be formed within a shell by silicone elastomer membrane partitions.

3.1.8 *orientation means, n*—any mark or palpable portion of an implantable breast prosthesis to assist the surgeon in positioning the implant.

3.1.9 *saline, n*—sodium chloride injection USP.

3.1.10 *shell, n*—a silicone elastomer continuous layer or membrane container (sac) that encloses a lumen or multiple lumens of an implantable breast prosthesis.

3.1.11 *silicone elastomer, n*—an elastomer containing cross-linked silicone polymer and fumed amorphous (non-crystalline) silica as a reinforcing filler.

3.1.12 *silicone gel, n*—a semisolid material consisting of a crosslinked silicone polymer network in which liquid silicone polymer is held (see definition of *gel* in Terminology F1251).

3.1.13 *valve, n*—user-sealable or self-sealing opening in an inflatable or gel saline prosthesis, extending from the exterior surface of the shell into a lumen, designed to facilitate adding or removing saline to or from the prosthesis to increase or decrease prosthesis volume.

4. Significance and Use

4.1 This specification contains requirements based on state-of-the-art science and technology as applicable to various considerations that have been identified as important to ensure reasonable safety and efficacy in implantable breast prostheses.

4.1.1 This specification is not intended to limit the science and technology which may be considered and applied to ensure performance characteristics of breast prostheses in intended applications. When new information becomes available or changes in state-of-the-art science and technology occur and relevance to prostheses has been established by valid science, it is intended that this specification will be revised in keeping with the new information or advances in state-of-the-art science.

5. Materials and Manufacture

5.1 *Silicone Elastomer*—Select and specify elastomers for use in implantable breast prostheses in keeping with Guides F2038 and F2042.

5.1.1 *Fabrication*—Fabrication techniques must necessarily be varied depending on the type of elastomer, the portion of an implantable breast prosthesis fabricated, its shape and its location and function on the prosthesis.

5.1.2 *Vulcanization and Postcure*—Time and temperature of vulcanization and postcure must be adjusted with consideration of the elastomer type and the multi-step fabrication requirements of specific prostheses. Final postcure is typically done only after the shell or shells and all other portions have been completely assembled. Time and temperature of final postcure shall be adequate to drive the chemistry of vulcanization of all elastomers to completion and remove by-products of the cure in keeping with the chemical stoichiometry of the specific cure systems (for example, after postcure no additional vulcanization should occur when heated additionally at the recommended cure temperature).

5.2 *Silicone Gel*—Select and specify ingredients in keeping with Guides F2038 and F2042.

5.2.1 *Fabrication, Vulcanization, and Postcure:*

5.2.1.1 *Fabrication and Curing*—Unvulcanized liquid gel is typically placed in the lumen of a shell and cured and postcured in situ while the shell is maintained in its desired final shape. Fabrication techniques must necessarily be varied to satisfy the requirements of the specific implant type and shape.

5.2.1.2 *Vulcanization and Postcure*—The time and temperature of vulcanization and postcure shall be adequate to drive the vulcanization chemistry of the gel to completion in keeping with the chemical stoichiometry of specific silicone gels. When postcure is adequate, silicone gel does not undergo further vulcanization with additional heating at the cure temperature.

6. Volume and Dimensions

6.1 *Volumes of Prostheses:*

6.1.1 *Silicone Gel and Gel-Saline Prostheses*—Because silicone gel has a specific gravity of approximately one, volumes of silicone gel-containing prostheses are typically controlled by weight. 1 g = approximately 1 cm³. The weight tolerance of a silicone gel-containing prosthesis with volume ≥250 cm³ shall be ±5 g. The weight tolerance of a silicone gel-containing prosthesis with volume <250 cm³ shall be ±2 % of labeled volume in equivalent grams.

6.1.2 *Gel-Saline Prostheses*—The design or maximum recommended volume of saline fill shall be listed in the labeling.

6.2 *Dimensions*—The ranges of shapes, volumes, base sizes, and anterior projections shall be determined by the manufacturer. Pertinent information shall be contained in the labeling.

7. Fixation Sites

7.1 Fixation sites shall be optional features on a silicone gel implantable breast prosthesis. When used, the size and locations of fixation sites shall be clearly stated in the labeling.

8. Orientation Means

8.1 Orientation means shall be optional features on a silicone gel implantable breast prosthesis. When orientation means are claimed, the location and recommended techniques for use shall be clearly described in the labeling.

9. Test Methods and Requirements

9.1 *Biocompatibility*:

9.1.1 *Practice F748*—New or existing materials shall be in compliance with Practice F748 or other acceptable standards such as ISO/AAMI/ANSI 10993-1. Biocompatibility assays of materials with no or limited history of prior biocompatibility testing and successful clinical use for implant applications shall follow guidelines of Practice F748. Assays recommended by Practice F748 include cell culture cytotoxicity assays, short-term intramuscular implantation assay, short-term subcutaneous assay, carcinogenicity, long-term implant test, systemic injection (acute toxicity) assay, sensitization assay, mutagenicity, and pyrogenicity.

9.1.2 *Silicone Gel Prostheses*—Test specimens for chronic implantation assays (carcinogenicity and long term implant tests) shall be fabricated from the same combination of silicone elastomer and gel and by the same or similar procedures and conditions used in fabricating prostheses. The thickness of shell in specimens shall be typical of thickness used in prostheses.

NOTE 1—To minimize palpability of prostheses and to effectively mimic the softness of breast tissue, silicone gels used in implantable breast prostheses must be soft (have low modulus). State-of-the-art silicone gels with required low modulus are also low strength. When implanted long term without an enclosing silicone elastomer shell, silicone gel may not retain its physical shape and integrity. Clinical implantation of free silicone gel sans shell is neither intended nor recommended. If shell rupture occurs in an implanted silicone gel breast prosthesis, resulting in direct contact between silicone gel and tissue, surgery for removal of the ruptured prosthesis (with or without prosthetic replacement) and any free gel is recommended. To help assure relevancy of long term biocompatibility assays in animals to recommended clinical use of silicone gel implantable breast prostheses, the specimens used in chronic biocompatibility assays shall have silicone gel contained in an enclosing silicone elastomer shell, similar to silicone gel prostheses. Specimens of free silicone gel may be used in all other biocompatibility assays as specified in Practice F748 for implants used in tissue and tissue fluid contact applications, including short-term intramuscular implantation assay.

9.1.3 *Prior Biocompatibility Assays*—When prior biocompatibility data are available for silicone elastomers and gels that may also have histories of clinical use in breast implants, even if not done by the exact protocols described in more recently developed biocompatibility test method standards, such data may satisfy all or part of the specific biocompatibility requirements of Practice F748 or equivalent methodology.

9.2 *Physical Properties*:

9.2.1 *Test Procedure*—Silicone prostheses shall demonstrate an acceptable response in physical property tests. Prostheses for testing should be selected from standard production batches, or equivalent, which have gone through all manufacturing processes, including sterilization. Unless otherwise specified, the standard temperature for testing shall be $23 \pm 2^\circ\text{C}$ ($73.4 \pm 3.6^\circ\text{F}$). When testing at any other temperature is required, one of the temperatures specified in Practice D1349 shall be used. Requirements are as follows:

9.2.1.1 *Shell Test Method*—Cut the test specimens from units made from standard production batches, or equivalent, which have gone through all manufacturing processes, including sterilization. With silicone gel prostheses, remove gel and clean shell with appropriate polar (for example, 2-propanol) or non-polar (aliphatic, aromatic, or chlorinated hydrocarbon) solvent, or both. If solvent cleaned, condition shell afterwards for 3 h at 150°F (65.6°C) in an air circulation oven to remove solvent. Test shells shall be wiped clean (not soaked or submerged), using lint-free tissue and isopropyl alcohol, then left to dry at room temperature for at least two hours. Cut required tensile test dumbbell specimens from shells with Test Methods D412 dies. Specimens shall be conditioned before testing for at least 3 h at $23 \pm 2^\circ\text{C}$ ($73.4 \pm 3.6^\circ\text{F}$).

(1) *Percent Elongation*—Percent elongation shall be $\geq 350\%$ when tested in accordance with Test Methods D412, Die C.

(2) *Breaking Strength*—The ultimate breaking force shall be not less than 11.12 N (2.5 lbs) when tested in accordance with Test Methods D412, Die C.

(3) *Tensile Set*—To determine tensile set at 300 % elongation, stress the specimen for 3 min then allow 3 min for relaxation. The tensile set shall be $< 10\%$, as determined in accordance with Test Methods D412.

(4) *Critical Fused or Adhered Joints*—Joints or seams that are critical to the integrity of the prosthesis envelope shall not fail when the shell adjacent to the joint is stressed to 200 % elongation for 10 s (see Fig. 1).

(5) *Non-Critical Fused or Adhered Joints*—Fused joints or seams that are bonded to the prosthesis envelope but are not critical to the envelope integrity (fixation sites, orientation means, valve covers, and so forth.) shall not fail when the shell adjacent to the joint is stressed to 100 % elongation for 10 s (see Fig. 1).

(6) *Shell Rupture/Failure Testing*—No standard test for assessing shell rupture/failure has yet been developed. When such test method has been developed it will be added to this specification.

(7) *Shell Leakage Testing for Type II and Type III Devices*—Fill a 5 to 8 qt stainless steel bowl with 70 % isopropyl alcohol. Submerge patched shell in bowl and gently apply pressure to the shell assembly. Visually inspect for any bubbles. Reposition shell in hand until entire surface of shell has been tested while exposed. Reject shells whenever any bubbles are seen.

9.2.1.2 *Valve Competence Test Method for Type II and Type III Devices*—Prior to testing, manipulate valve to duplicate its use for filling an inflatable lumen with saline as described in

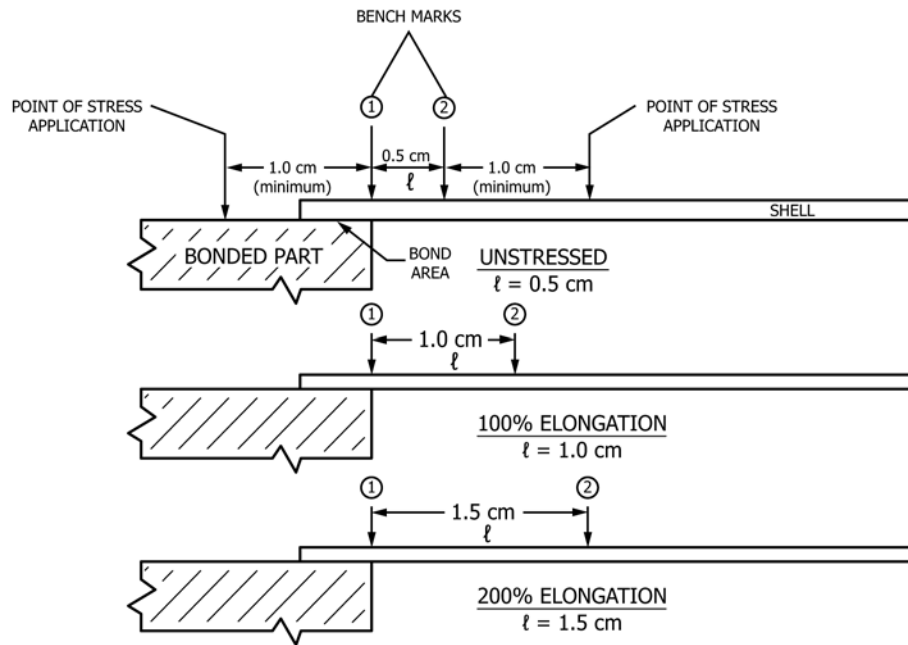

FIG. 1 Testing Fused or Adhered Joints

instructions for use. Test the valve at both high and low retrograde pressures. Use air, distilled water, or isotonic saline as the test medium. Pressures, in the order to be tested, are 30 cm and 3 cm H₂O pressure respectively. Maintain each test pressure for 5 min. When air is the test medium, immerse valve opening in water to check for leakage (bubbles). With water or isotonic saline as the test medium, check for droplets at the valve opening.

(1) *Test Requirements*—No observable or detectable leakage.

9.2.1.3 *Silicone Gel Test Method*—Remove test samples of gel from finished production batches of silicone gel-containing implantable breast prostheses after all manufacturing, including sterilization has been completed.

(1) *Weight Loss from Heating*—When a 2 to 3 g sample is spread in an aluminum weighing cup measuring approximately 60 mm in diameter and heated in an air circulating oven for 4 h at approximately 150°C the weight loss shall not exceed 1 %.

9.2.1.4 *Gel Cohesion—Cone/Pendant Test Method*—This test is particularly useful to manufacturers for use in silicone gel development and quality control of unused silicone gel breast implants in that it provides quantitative results.

(1) *Requirements*—The cohesive properties of silicone gel shall be considered suitable for use in silicone gel breast prostheses if there is no separation of any component of the gel pendant and the length of the pendant gel remains <4.5 cm when tested in accordance with the method in Annex A1.

NOTE 2—The test results from cone/pendant gel testing are highly dependent on strict adherence to the specifications for the test apparatus and the procedures described in Annex A1. Precision and bias data for this method have not been established.

NOTE 3—With firmer more cohesive gels, a manufacturer may determine that an alternative test method, through an appropriate correlation study, may satisfy this gel cohesion test method to demonstrate equivalent or better cohesiveness and the no gel separation requirement.

9.2.1.5 *Gel Bleed Test Method*—See Annex A2.

(1) *Requirements*—The allowable quantities of gel bleed in this testing have not been established.

10. Other Test Methods

10.1 Additional specific tests, as described in the FDA guidance document should be addressed.

10.2 *Gel Penetration Test Method Described in Annex A3*—This in-process test is particularly useful to manufacturers for use in silicone gel development and quality control in that it provides quantitative results. This test method is used to characterize the firmness of very soft gel and resilient gel and is a way a manufacturer can ensure the gel mixing process has provided gel penetration results within the device manufacturer's specification. The manufacturer will determine the appropriate weight and diameter of the foot/shaft assembly based on the softness of the gel that is being tested. Typical foot shaft assemblies range from 1/8-in. diameter to 1 3/4-in. diameter and the weight ranges from approximately 12 to 57 g. The manufacturer may work with the gel supplier to determine the size/weight combination that will provided the best characterization for the gel being tested. Because of the variability in the foot/shaft assemblies' diameters and weights, the time between depressing the release trigger and releasing the trigger will vary; however, the time should allow the probe to stop its descent by the time the release trigger is released. Typical times for this activity range from approximately 5 to 15 s. The manufacture shall determine the appropriate time and tolerances based on the gel being tested, and this should be consistent for each type of gel.

10.2.1 *Requirements*—Although no specification limits have been established, this test may be useful to further characterize the gel. This test is not mandatory.

NOTE 4—With firmer more cohesive gels, a manufacturer may determine that an alternative test method, through an appropriate correlation study, may satisfy this gel penetration test method.

11. Sterilization

11.1 Implantable breast prostheses may be supplied pre-sterilized in accordance with current ANSI/AAMI and PDA procedures and the Quality System Regulations established by FDA.⁶

11.2 If user sterilization or re-sterilization of prostheses are intended, validated instructions for cleaning and sterilization shall be supplied with the package insert.

12. Packaging, Labeling, and Package Inserts

12.1 *Packaging*—Prostheses shall be packaged to protect against damage and maintain cleanliness and sterility during the customary conditions of processing, storage, handling and distribution.

12.2 *Labeling*—Each package shall be labeled in a manner that ensures the labeling arrives at the point of use with the prostheses or is available by electronic labeling. The package labeling shall include the following information:

- 12.2.1 Manufacturer's name and address,
- 12.2.2 Product name, shape, type and lot number,

⁶ Federal Register, Vol. 61, No. 195, Monday, October 7, 1996, 31 CFR § 820 Rules and Regulations.

- 12.2.3 Volume and dimension information,
- 12.2.4 Date (month and year) of sterilization or expiration date,
- 12.2.5 Special storage requirements, if any,
- 12.2.6 Self-adhering label suitable for application to the patient's medical records containing following information:
 - 12.2.6.1 Prosthesis name and manufacturer;
 - 12.2.6.2 Lot number; and
 - 12.2.6.3 Type and volume.

12.3 *Implant Marking*—Each individual implant unit shall be clearly and permanently marked with a manufacturer's unique identifying mark and the nominal volume of the device in millilitres (mL) or cubic centimetres (cm³). The marking method shall not compromise the strength nor integrity of the device.

12.4 *Package Insert*—The package insert shall contain information: to identify the manufacturer; to describe the prosthesis; on storage, handling, cleaning and sterilization; to provide directions for use to the surgeon, and warnings and precautions concerning known and potential patient adverse reactions and risks.

13. Keywords

13.1 breast prosthesis; gel-saline prosthesis; implant; saline inflatable prosthesis; silicone elastomer; silicone gel prosthesis; soft tissue implant

iTech Standards
(<https://standards.iteh.ai>)
Document Preview

ANNEXES

A1. GEL COHESION TEST METHOD

<https://standards.iteh.ai/catalog/standards/sist/d9bb7516-ec16-416a-ae02-3470d6665a69/astm-f703-07>

A1.1 Apparatus

- A1.1.1 *Test cup*, volume 100 cm³ (Fig. A1.1).
- A1.1.2 *Test stand*, optional (Figs. A1.2 and A1.3).

A1.2 Preparation for Testing

- A1.2.1 Clean test fixture thoroughly using isopropyl alcohol. Dry thoroughly.
- A1.2.2 Ensure that the test sample is at room temperature.

A1.3 Procedure for Testing

- A1.3.1 Place the cohesion test cup with gate in place in the test stand.
- A1.3.2 A representative test sample of gel should be removed from a single implant to allow the gel to be removed as one cohesive mass (completely fill the test cup so that the gel is flush with the upper opening of the cup). The total mass (~98

to 105 g) must remain within the rim of the test cup. Care should be taken not to underfill the test fixture.

A1.3.3 Make sure that the gel completely covers the bottom of the test fixture.

A1.3.4 Exercise care in removing gel and transferring gel to the test cup. Severe mixing, handling, or entrapment may produce erroneous results.

A1.3.5 Once the test cup(s) are filled, allow for a 10 min equilibrium time to ensure that the gel mass has been given time to press on the gate.

A1.3.6 After the 10 min, open the gate(s) for 30 min and allow the gel to flow unrestricted through the lower opening.

A1.3.7 Measure the length of the pendent portion of the gel.

A1.3.8 The specimen shall meet the requirements of the test if there is no separation and the pendent length is less than (<) 4.5 cm.

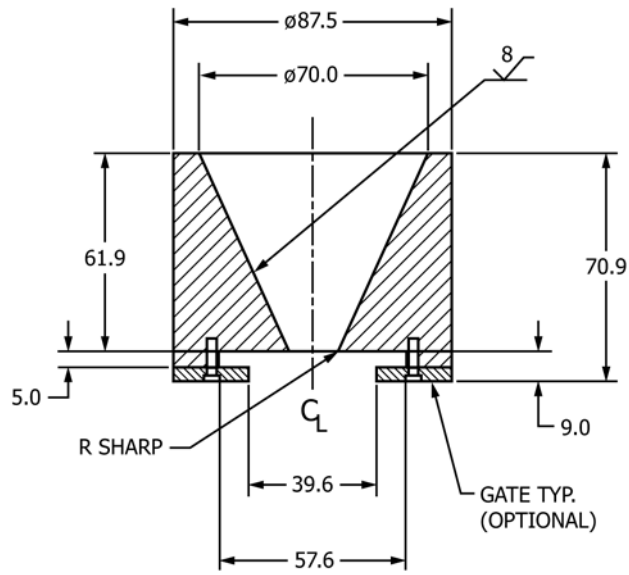

SECTION A-A

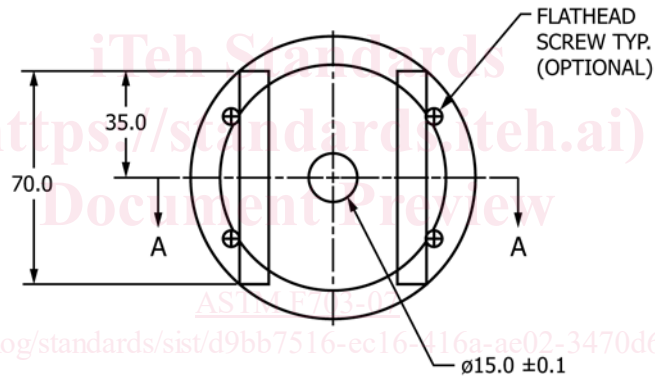

NOTE 1—Dimensions are in millimetres.

FIG. A1.1 Test Cup

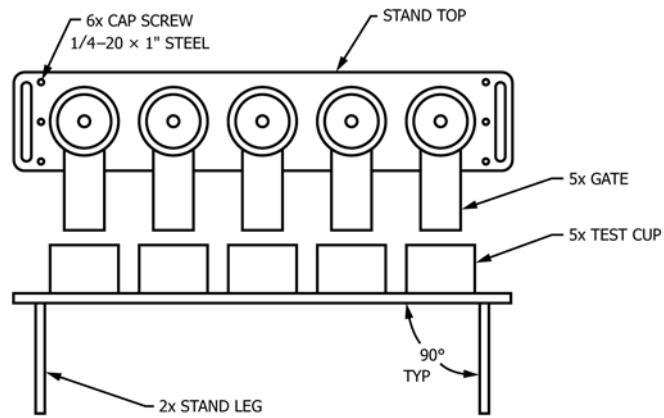

FIG. A1.2 Test Stand Assembly (Optional)