**Technical product documentation (TPD) —
Dimensioning and indication of knurling**

*Documentation technique de produits (TPD) — Cotation et indication du
moletage*

iTeh STANDARD PREVIEW
(standards.iteh.ai)

[ISO 13444:2012](https://standards.iteh.ai/catalog/standards/sist/11ec866e-efcf-49f1-a26d-858cbee848ca/iso-13444-2012)

[https://standards.iteh.ai/catalog/standards/sist/11ec866e-efcf-49f1-a26d-
858cbee848ca/iso-13444-2012](https://standards.iteh.ai/catalog/standards/sist/11ec866e-efcf-49f1-a26d-858cbee848ca/iso-13444-2012)



iTeh STANDARD PREVIEW (standards.iteh.ai)

ISO 13444:2012

<https://standards.iteh.ai/catalog/standards/sist/11ec866e-efcf-49f1-a26d-858cbee848ca/iso-13444-2012>



COPYRIGHT PROTECTED DOCUMENT

© ISO 2012

All rights reserved. Unless otherwise specified, no part of this publication may be reproduced or utilized in any form or by any means, electronic or mechanical, including photocopying and microfilm, without permission in writing from either ISO at the address below or ISO's member body in the country of the requester.

ISO copyright office
Case postale 56 • CH-1211 Geneva 20
Tel. + 41 22 749 01 11
Fax + 41 22 749 09 47
E-mail copyright@iso.org
Web www.iso.org

Published in Switzerland

Foreword

ISO (the International Organization for Standardization) is a worldwide federation of national standards bodies (ISO member bodies). The work of preparing International Standards is normally carried out through ISO technical committees. Each member body interested in a subject for which a technical committee has been established has the right to be represented on that committee. International organizations, governmental and non-governmental, in liaison with ISO, also take part in the work. ISO collaborates closely with the International Electrotechnical Commission (IEC) on all matters of electrotechnical standardization.

International Standards are drafted in accordance with the rules given in the ISO/IEC Directives, Part 2.

The main task of technical committees is to prepare International Standards. Draft International Standards adopted by the technical committees are circulated to the member bodies for voting. Publication as an International Standard requires approval by at least 75 % of the member bodies casting a vote.

Attention is drawn to the possibility that some of the elements of this document may be the subject of patent rights. ISO shall not be held responsible for identifying any or all such patent rights.

ISO 13444 was prepared by Technical Committee ISO/TC 10, *Technical product documentation*, Subcommittee SC 6, *Mechanical engineering documentation*.

iTeh STANDARD PREVIEW (standards.iteh.ai)

[ISO 13444:2012](https://standards.iteh.ai/catalog/standards/sist/11ec866e-efcf-49f1-a26d-858cbee848ca/iso-13444-2012)

<https://standards.iteh.ai/catalog/standards/sist/11ec866e-efcf-49f1-a26d-858cbee848ca/iso-13444-2012>

Introduction

This International Standard covers knurling on workpieces with standardized diametral pitches. It does not deal with the knurling tools; these are outside the scope of ISO/TC 10.

This International Standard includes dimensional relations for straight and diamond knurling on cylindrical surfaces having teeth of uniform pitch parallel to the axis of the cylinder or at a helix angle of 30° with the axis of work.

The knurling is made by displacement of the material on the surface of a workpiece when rotated under pressure against a knurling tool.

The recommendations given are applicable for general purposes. They are intended to improve the uniformity and appearance of knurling, reduce the production of defective work, as well as decrease the number of tools required.

In Annex A, an alternative method of dimensioning and indication of knurling is presented. This method uses a module for the calculation of the knurling. Note that this method requires different knurling tools than those used in the method presented in the main body of this International Standard.

iTeh STANDARD PREVIEW (standards.iteh.ai)

[ISO 13444:2012](https://standards.iteh.ai/catalog/standards/sist/11ec866e-efcf-49f1-a26d-858cbee848ca/iso-13444-2012)

<https://standards.iteh.ai/catalog/standards/sist/11ec866e-efcf-49f1-a26d-858cbee848ca/iso-13444-2012>

Technical product documentation (TPD) — Dimensioning and indication of knurling

1 Scope

This International Standard specifies a series of knurling dimensions intended for general use in mechanical engineering and is intended to avoid an unnecessary multiplicity of tools by restricting the profile angle to 90° and by restricting the selection of diametral pitches.

2 Normative references

The following referenced documents are indispensable for the application of this document. For dated references, only the edition cited applies. For undated references, the latest edition of the referenced document (including any amendments) applies.

ISO 128-34:2001, *Technical drawings — General principles of presentation — Part 34: Views on mechanical engineering drawings*

ISO 129-1:2004, *Technical drawings — Indication of dimensions and tolerances — Part 1: General principles*

3 Terms and definitions

iTeh STANDARD PREVIEW
(standards.iteh.ai)

For the purposes of this International Standard, the following terms and definitions apply.

3.1
knurling tool
knurl
tool or die used to produce a raised surface on a workpiece by a cutting or rolling process

[ISO 13444:2012](https://standards.iteh.ai/catalog/standards/sist/11ec866e-efcf-49f1-a26d-858cbee848ca/iso-13444-2012)

<https://standards.iteh.ai/catalog/standards/sist/11ec866e-efcf-49f1-a26d-858cbee848ca/iso-13444-2012>

3.2
knurling
patterned raised surface on a workpiece produced by a knurl

3.3
diametral pitch

p
radial distance between two teeth measured on the outer diameter of the knurling.

4 Types of knurling

Two types of knurling are standardized:

- a straight knurling type A (see Figure 1);
- a diamond knurling type B (see Figure 2).

Other types are possible, but they need special tools (see Annex A).

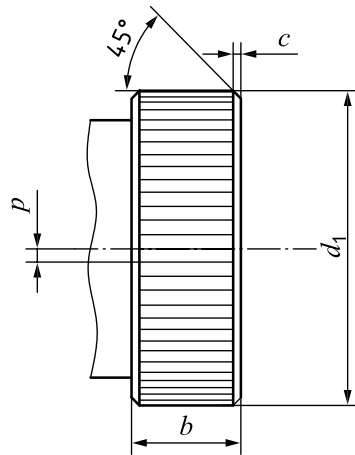

Figure 1 — Knurling type A

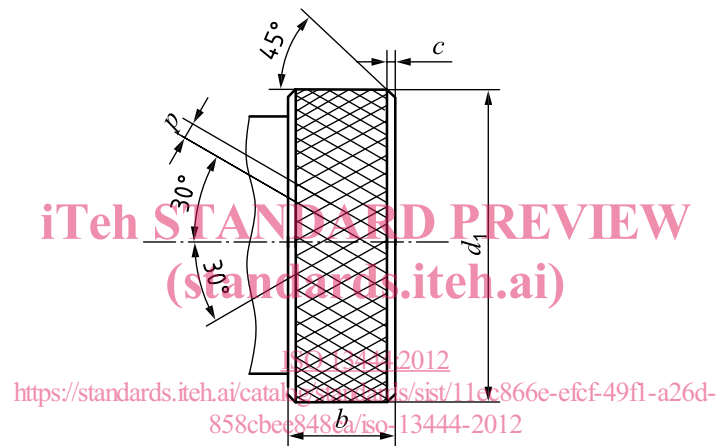

Figure 2 — Knurling type B

5 Shape of the knurling

The shape of the knurling when sectioned perpendicular to the knurl teeth describes the knurling parameters (see Figure 3).

The profile of the groove used on the knurling shall be specified by a cross-section perpendicular to the groove (see Figure A.3).

If b is smaller than 6 mm, c shall be specified, and shall be smaller than p .

A radius may be chosen instead of a chamfer.

6.5 Knurling data

Recommendations for preferred data and relations between diameter d_1 , diametral pitch p and the width of the knurled feature b are given in Table 1.

Table 1 — Knurling data relation

Dimensions in millimetres

Outside diameter d_1		Diametral pitch p for width b				
above	Up to and including	2 to 4	4 to 8	8 to 16	16 to 32	> 32
—	Ø3	0,4	0,4	0,5	—	—
Ø3	Ø6	0,4	0,5	0,6	0,6	0,6
Ø6	Ø10	0,5	0,6	0,6	0,8	0,8
Ø10	Ø20	0,6	0,6	0,8	1	1
Ø20	Ø30	0,6	0,8	0,8	1	1
Ø30	Ø60	0,8	0,8	1	1,2	1,2
Ø60	Ø100	0,8	1	1,2	1,2	1,6
Ø100	—	—	1	1,6	1,6	1,6

iTech STANDARD PREVIEW
(standards.iteh.ai)

ISO 13444:2012

<https://standards.iteh.ai/catalog/standards/sist/11ec866e-efcf-49f1-a26d-858cbee848ca/iso-13444-2012>

7 Designation

The designation of knurling is dependent on the diameter and the width of the feature to be knurled.

The designation of knurling itself on the drawing shall consist of:

- a reference to this International Standard;
- the letter for the type of knurling (A or B);
- the pitch of the knurling.

For a feature with $d_1 = \text{Ø}30$ mm and $b = 12$ mm, the pitch p is 0,8 mm according to Table 1. The designation for a straight knurling is:

ISO 13444 – A p0,8

8 Presentation on drawings

The knurling shall be presented in accordance with ISO 128-34 and dimensioned in accordance with ISO 129-1. Figure 4 shows an example of a diamond knurling type B; the pitch was chosen from Table 1.

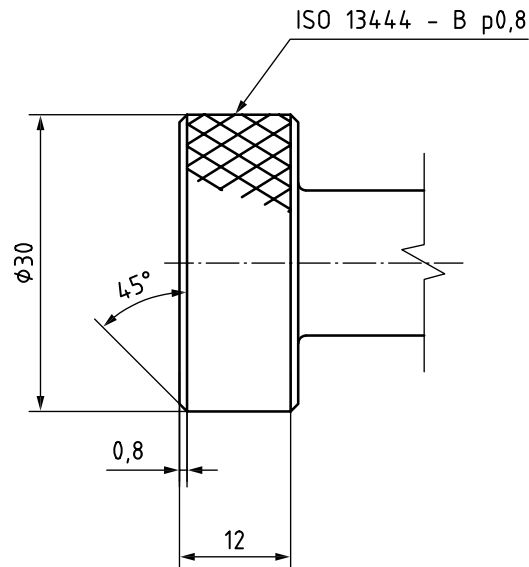

Figure 4 — Presentation and dimensioning of the knurling (example)

iTeh STANDARD PREVIEW
(standards.iteh.ai)

ISO 13444:2012

<https://standards.iteh.ai/catalog/standards/sist/11ec866e-efcf-49f1-a26d-858cbee848ca/iso-13444-2012>