

---

---

**Microscopes — Screw threads for  
objectives and related nosepieces**

*Microscopes — Filetages de fixation des objectifs et des porte-objectifs  
correspondants*

**iTeh STANDARD PREVIEW**  
**(standards.iteh.ai)**

[ISO 8038:2011](https://standards.iteh.ai/catalog/standards/sist/6128b26c-2d68-4c5b-a825-d6ab1b307e27/iso-8038-2011)

[https://standards.iteh.ai/catalog/standards/sist/6128b26c-2d68-4c5b-a825-  
d6ab1b307e27/iso-8038-2011](https://standards.iteh.ai/catalog/standards/sist/6128b26c-2d68-4c5b-a825-d6ab1b307e27/iso-8038-2011)



**PDF disclaimer**

This PDF file may contain embedded typefaces. In accordance with Adobe's licensing policy, this file may be printed or viewed but shall not be edited unless the typefaces which are embedded are licensed to and installed on the computer performing the editing. In downloading this file, parties accept therein the responsibility of not infringing Adobe's licensing policy. The ISO Central Secretariat accepts no liability in this area.

Adobe is a trademark of Adobe Systems Incorporated.

Details of the software products used to create this PDF file can be found in the General Info relative to the file; the PDF-creation parameters were optimized for printing. Every care has been taken to ensure that the file is suitable for use by ISO member bodies. In the unlikely event that a problem relating to it is found, please inform the Central Secretariat at the address given below.

**iTeh STANDARD PREVIEW**  
**(standards.iteh.ai)**

ISO 8038:2011

<https://standards.iteh.ai/catalog/standards/sist/6128b26c-2d68-4c5b-a825-d6ab1b307e27/iso-8038-2011>



**COPYRIGHT PROTECTED DOCUMENT**

© ISO 2011

All rights reserved. Unless otherwise specified, no part of this publication may be reproduced or utilized in any form or by any means, electronic or mechanical, including photocopying and microfilm, without permission in writing from either ISO at the address below or ISO's member body in the country of the requester.

ISO copyright office  
Case postale 56 • CH-1211 Geneva 20  
Tel. + 41 22 749 01 11  
Fax + 41 22 749 09 47  
E-mail [copyright@iso.org](mailto:copyright@iso.org)  
Web [www.iso.org](http://www.iso.org)

Published in Switzerland

## Foreword

ISO (the International Organization for Standardization) is a worldwide federation of national standards bodies (ISO member bodies). The work of preparing International Standards is normally carried out through ISO technical committees. Each member body interested in a subject for which a technical committee has been established has the right to be represented on that committee. International organizations, governmental and non-governmental, in liaison with ISO, also take part in the work. ISO collaborates closely with the International Electrotechnical Commission (IEC) on all matters of electrotechnical standardization.

International Standards are drafted in accordance with the rules given in the ISO/IEC Directives, Part 2.

The main task of technical committees is to prepare International Standards. Draft International Standards adopted by the technical committees are circulated to the member bodies for voting. Publication as an International Standard requires approval by at least 75 % of the member bodies casting a vote.

Attention is drawn to the possibility that some of the elements of this document may be the subject of patent rights. ISO shall not be held responsible for identifying any or all such patent rights.

ISO 8038 was prepared by Technical Committee ISO/TC 172, *Optics and photonics*, Subcommittee SC 5, *Microscopes and endoscopes*.

This second edition cancels and replaces the editions of ISO 8038-1:1997 and ISO 8038-2:2001, which have been technically revised.

**iTeh STANDARD PREVIEW**  
**(standards.iteh.ai)**  
ISO 8038:2011  
<https://standards.iteh.ai/catalog/standards/sist/6128b26c-2d68-4c5b-a825-d6ab1b307e27/iso-8038-2011>

**iTeh STANDARD PREVIEW**  
**(standards.iteh.ai)**

ISO 8038:2011

<https://standards.iteh.ai/catalog/standards/sist/6128b26c-2d68-4c5b-a825-d6ab1b307e27/iso-8038-2011>

# Microscopes — Screw threads for objectives and related nosepieces

## 1 Scope

This International Standard specifies the dimensions of screw thread types for connecting a microscope objective to the nosepiece.

NOTE 1 The use of these screw thread types is recommended for microscopes unless other fittings are required for optical or design reasons.

NOTE 2 A specific combination of eyepiece, objective and tube lens (if provided, e.g. in an infinity-corrected optical system) is frequently used to correct aberrations. Therefore the combination of an objective from one manufacturer and the tube lens or eyepiece from another manufacturer, although conforming to this International Standard, may cause error in magnification and/or loss of image quality.

## 2 Types of screw thread

Types of screw thread are listed in Table 1.

ISO 8038:2011  
<https://standards.iteh.ai/catalog/standards/sist/6128026c-2d68-4c5b-a825-d6ab1b307e27/iso-8038-2011>  
**Table 1 — Types of screw thread**

	Name of screw type		
	<b>Whitworth screw</b>	RMS <sup>a</sup>	W26
<b>Metric screw</b>	M25	M27	M32

<sup>a</sup> With the exception of the length of the thread lug (see Figure 1), the values of the RMS thread conform to the internationally used screw thread defined by the Royal Microscopical Society Standard (RMS Standard) in 1936.

## 3 Basic dimensions

### 3.1 General

The basic dimensions of each screw thread type shall be in accordance with those given in Table 2 and illustrated in Figure 1.

**Table 2 — Basic dimensions of the screw thread**

Dimensions	Symbol	Value				
		Whitworth screw		Metric screw		
		RMS	W26	M25	M27	M32
<b>Angle of thread</b>	$\alpha$	55°	55°	60°	60°	60°
<b>Pitch</b>	$p$	0,706 mm	0,706 mm	0,75 mm	0,75 mm	0,75 mm
<b>Height of fundamental triangle</b>	$H$	0,678 mm	0,678 mm	0,65 mm	0,65 mm	0,65 mm
<b>Nominal diameter</b>	$D$	20,320 mm	26 mm	25 mm	27 mm	32 mm

3.2 Tolerances

Limit of sizes and tolerances of each screw thread type shall be in accordance with those given in Tables 3, 4, 5, 6, 7 and illustrated in Figures 1 and 2.

Table 3 — Limit of size and tolerances of RMS

Dimensions in millimetres

Dimensions for		Major diameter	Pitch diameter	Minor diameter	Calculated play between internal and external threads		Allowances	Tolerance	Thread lug			
Internal thread	max.	D	20,396	D <sub>2</sub>	19,944	D <sub>1</sub>	19,492	Minimum play	Maximum play	+0,076	0,076	—
	min.		20,320		19,868		19,416			0,000		—
External thread	max.	d	20,274	d <sub>2</sub>	19,822	d <sub>1</sub>	19,370	0,046	0,198	-0,046	0,076	5,000
	min.		20,198		19,746		19,294			-0,122		—

Table 4 — Limit of size and tolerances of W26

Dimensions in millimetres

Dimensions for		Major diameter	Pitch diameter	Minor diameter	Calculated play between internal and external threads		Allowances	Tolerance	Thread lug			
Internal thread	max.	D	—	D <sub>2</sub>	25,660	D <sub>1</sub>	25,300	Minimum play	Maximum play	+0,076	0,190	—
	min.		26,000		25,580		25,200			0,000		—
External thread	max.	d	25,930	d <sub>2</sub>	25,520	d <sub>1</sub>	25,070	0,070	0,246	-0,070	0,100	5,000
	min.		25,830		25,440		24,940			-0,170		—

Table 5 — Limit of size and tolerances of M25

Dimensions in millimetres

Dimensions for		Major diameter	Pitch diameter	Minor diameter	Calculated play between internal and external threads		Allowances	Tolerance	Thread lug			
Internal thread	max.	D	—	D <sub>2</sub>	24,659	D <sub>1</sub>	24,378	Minimum play	Maximum play	+0,190	0,190	—
	min.		—		24,513		24,188			0,000		—
External thread	max.	d	24,978	d <sub>2</sub>	24,491	d <sub>1</sub>	—	0,022	0,279	-0,022	0,140	5,000
	min.		24,838		24,380		—			-0,162		—

Table 6 — Limit of size and tolerances of M27

Dimensions in millimetres

Dimensions for		Major diameter		Pitch diameter		Minor diameter		Calculated play between internal and external threads		Allowances	Tolerance	Thread lug
Internal thread	max.	$D$	—	$D_2$	26,660	$D_1$	26,378	Minimum play	Maximum play	+0,190	0,190	—
	min.		—		26,513		26,188			0,000		—
External thread	max.	$d$	26,978	$d_2$	26,491	$d_1$	—	0,022	0,281	-0,022	0,140	4,500
	min.		26,838		26,379		—			-0,162		—

Table 7 — Limit of size and tolerances of M32

Dimensions in millimetres

Dimensions for		Major diameter		Pitch diameter		Minor diameter		Calculated play between internal and external threads		Allowances	Tolerance	Thread lug
Internal thread	max.	$D$	—	$D_2$	31,663	$D_1$	31,378	Minimum play	Maximum play	+0,190	0,190	—
	min.		—		31,513		31,188			0,000		—
External thread	max.	$d$	31,978	$d_2$	31,491	$d_1$	—	0,022	0,286	-0,022	0,140	5,000
	min.		31,838		31,377		—			-0,162		—

ISO 8038:2011

<https://standards.iteh.ai/catalog/standards/sist/6128b26c-2d68-4c5b-a825-d6ab1b307e27/iso-8038-2011>

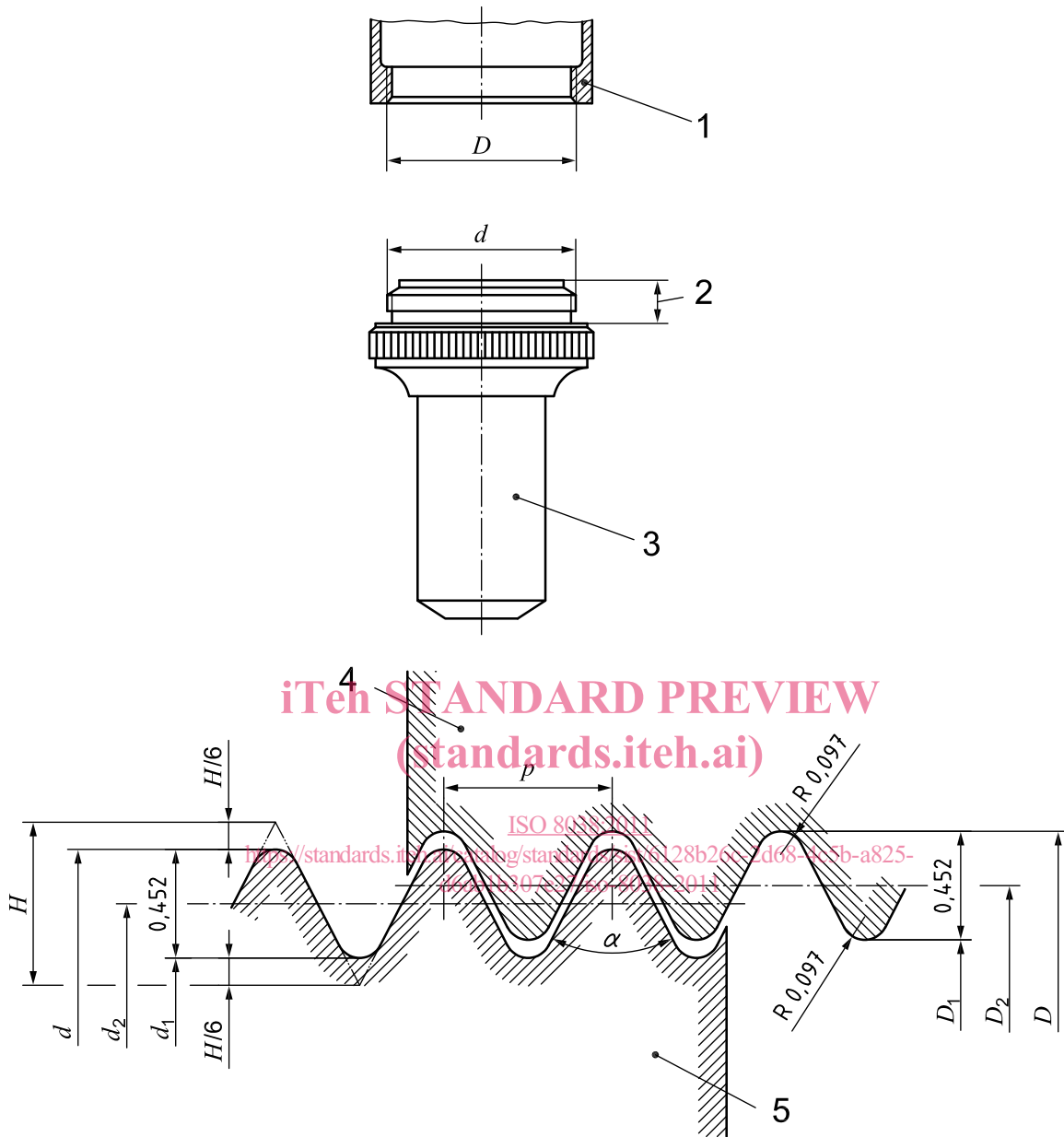

**Key**

- 1 tube, objective changer, etc.
- 2 thread lug
- 3 objective
- 4 internal thread
- 5 external thread

**Figure 1 — Definitions and basic dimensions of Whitworth screw threads, RMS and W26**



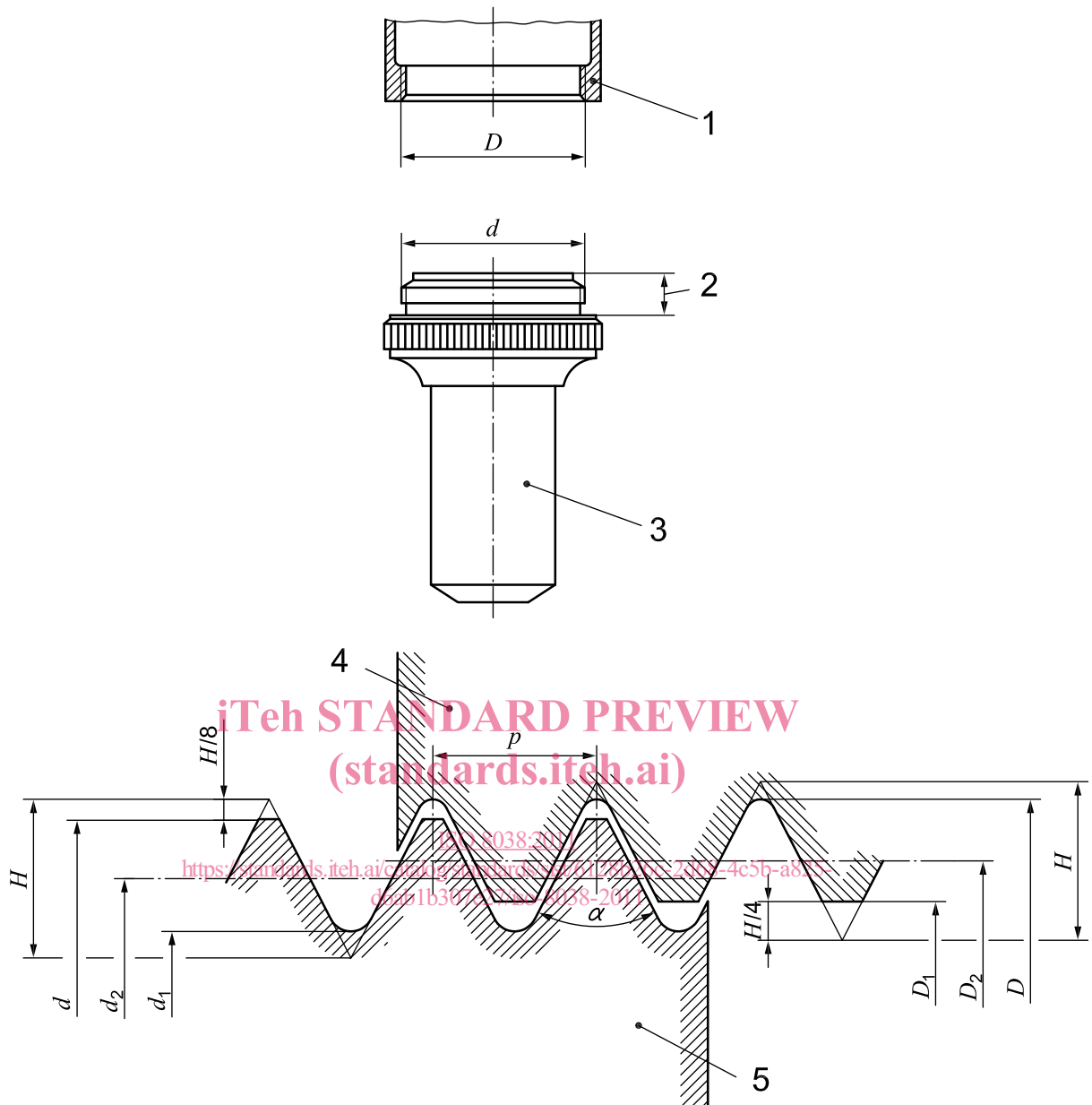

**Key**

- 1 tube, objective changer, etc.
- 2 thread lug
- 3 objective
- 4 internal thread
- 5 external thread

**Figure 2 — Definitions and basic dimensions of Metric screw threads, M25, M27 and M32**