**Indexable inserts for cutting tools —
Ceramic inserts with rounded corners —
Part 2:
Dimensions of inserts with cylindrical
fixing hole**

*Plaquettes amovibles pour outils coupants — Plaquettes en céramique
avec arrondi de pointe — Partie 2: Dimensions des plaquettes avec trou
de fixation cylindrique*

iTeh STANDARD PREVIEW
(standards.iteh.ai)

ISO 9361-2:2011

<https://standards.iteh.ai/catalog/standards/sist/56a01b25-3f88-49e7-b6bb-213b4455ab66/iso-9361-2-2011>



iTeh STANDARD PREVIEW (standards.iteh.ai)

ISO 9361-2:2011

<https://standards.iteh.ai/catalog/standards/sist/56a01b25-3f88-49e7-b6bb-213b4455ab66/iso-9361-2-2011>



COPYRIGHT PROTECTED DOCUMENT

© ISO 2011

All rights reserved. Unless otherwise specified, no part of this publication may be reproduced or utilized in any form or by any means, electronic or mechanical, including photocopying and microfilm, without permission in writing from either ISO at the address below or ISO's member body in the country of the requester.

ISO copyright office
Case postale 56 • CH-1211 Geneva 20
Tel. + 41 22 749 01 11
Fax + 41 22 749 09 47
E-mail copyright@iso.org
Web www.iso.org

Published in Switzerland

Foreword

ISO (the International Organization for Standardization) is a worldwide federation of national standards bodies (ISO member bodies). The work of preparing International Standards is normally carried out through ISO technical committees. Each member body interested in a subject for which a technical committee has been established has the right to be represented on that committee. International organizations, governmental and non-governmental, in liaison with ISO, also take part in the work. ISO collaborates closely with the International Electrotechnical Commission (IEC) on all matters of electrotechnical standardization.

International Standards are drafted in accordance with the rules given in the ISO/IEC Directives, Part 2.

The main task of technical committees is to prepare International Standards. Draft International Standards adopted by the technical committees are circulated to the member bodies for voting. Publication as an International Standard requires approval by at least 75 % of the member bodies casting a vote.

Attention is drawn to the possibility that some of the elements of this document may be the subject of patent rights. ISO shall not be held responsible for identifying any or all such patent rights.

ISO 9361-2 was prepared by Technical Committee ISO/TC 29, *Small tools*, Subcommittee SC 9, *Tools with cutting edges made of hard cutting materials*.

This second edition cancels and replaces the first edition (ISO 9261-2:1991), which has been technically revised.

ISO 9361 consists of the following parts, under the general title *Indexable inserts for cutting tools — Ceramic inserts with rounded corners*:

- Part 1: *Dimensions of inserts without fixing hole*
- Part 2: *Dimensions of inserts with cylindrical fixing hole*

<https://standards.iteh.ai/catalog/standards/sist/56a01b25-3f88-49e7-b6bb-213b4455ab66/iso-9361-2-2011>
 (standards.iteh.ai)

iTeh STANDARD PREVIEW
(standards.iteh.ai)

ISO 9361-2:2011

<https://standards.iteh.ai/catalog/standards/sist/56a01b25-3f88-49e7-b6bb-213b4455ab66/iso-9361-2-2011>

Indexable inserts for cutting tools — Ceramic inserts with rounded corners —

Part 2: Dimensions of inserts with cylindrical fixing hole

1 Scope

This part of ISO 9361 specifies the dimensions of indexable ceramic inserts with rounded corners, with cylindrical fixing hole, with 0° normal clearance. These inserts are primarily intended to be mounted by top and hole clamping or hole clamping alone on external and internal turning tools.

Ceramic cutting materials consist of a variety of oxides, nitrides and carbides. In contrast with hardmetals (including cermets), ceramics do not have a metallic binding matrix. Such ceramic materials are, for example, oxide ceramics (consisting primarily of aluminium oxide Al_2O_3), carboxide ceramics (consisting generally of a mixture of aluminium oxide and other materials, such as titanium carbide TiC) and nitride ceramics (consisting generally of a mixture of silicon nitride and other materials, such as yttrium oxide Y_2O_3 and aluminium oxide).

2 Normative references

The following referenced documents are indispensable for the application of this document. For dated references, only the edition cited applies. For undated references, the latest edition of the referenced document (including any amendments) applies.

ISO 1832:2004, *Indexable inserts for cutting tools — Designation*

ISO 9361-1, *Indexable inserts for cutting tools — Ceramic inserts with rounded corners — Part 1: Dimensions of inserts without fixing hole*

3 Types of inserts

The types of indexable ceramic inserts specified in this part of ISO 9361 are the following:

- TN: triangular inserts, with 0° normal clearance;
- SN: square inserts, with 0° normal clearance;
- CN: rhombic inserts, with 0° normal clearance and 80° included angle;
- DN: rhombic inserts, with 0° normal clearance and 55° included angle;
- VN: rhombic inserts, with 0° normal clearance and 35° included angle;
- RN: round inserts, with 0° normal clearance.

Inserts dealt with in this part of ISO 9361 are standardized without chip breakers.

In general, the inserts are used with chamfered and rounded cutting edges (see Clause 6).

Table B.1 gives the range of sizes for the inserts (see Annex B).

4 Tolerances

The indexable ceramic inserts, which are the subject of this part of ISO 9361, are provided in tolerance classes in accordance with ISO 1832.

Other tolerances are given in Tables 1 to 7.

5 Fixing hole

In order to guarantee interchangeability when mounting the insert, the diameter, d_1 , of the fixing hole, is related to the diameter, d , of the inscribed circle of the insert according to Table 1.

Table 1 — Fixing hole

Dimensions in millimetres

d		9,525	12,7	15,875	19,05
d_1	$\pm 0,08$	3,81	5,16	6,35	7,94

6 Cutting edge

6.1 Cutting edge condition

The cutting edge condition of the indexable ceramic inserts (see Figures 1 and 2) specified in this part of ISO 9361 shall be selected from those specified in ISO 1832.

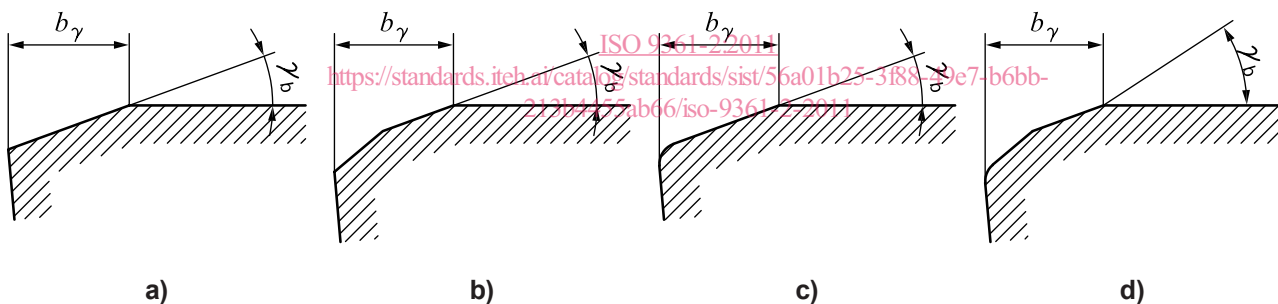

Figure 1 — Cutting edge condition 1 in this part of ISO 9361 related to ISO 1832

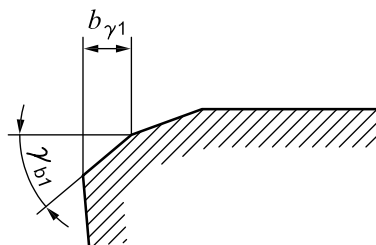

Figure 2 — Cutting edge condition 2 in this part of ISO 9361 related to ISO 1832

6.2 Additional information

The dimensions of chamfered cutting edges T, S, K or P may be specified, following the letter symbol for cutting edge condition in accordance with ISO 1832, namely symbols 8 and 10.

NOTE In the case of cutting edge conditions K and P, the first chamfer, $b_{\gamma 1}$, defined in accordance with Figure 2, is at the manufacturer's discretion and is not part of the additional information (i.e. five-digit number) as described in 6.2.

EXAMPLE A chamfered cutting edge T on an insert TN.A160412 with $b_{\gamma} = 0,2$ mm and $\gamma_b = 20^\circ$ is designated as follows, including the required additional information:

TN.A160412T 02020

7 Designation and marking

7.1 Designation

The designation of the indexable ceramic inserts which form the subject of this part of ISO 9361 shall conform to ISO 1832.

In addition to this designation, one or both of the following may be indicated:

- the number symbol for the additional information on cutting edge dimensions, in accordance with 6.2;
- the commercial designation of the ceramic grade.

iTeh STANDARD PREVIEW
(standards.iteh.ai)

7.2 Marking

The following symbol, at least, shall be marked on the insert itself (except when this is difficult to carry out on smaller inserts): symbol of the commercial designation of the ceramic grade.

<https://standards.iteh.ai/catalog/standards/sist/56a01b25-3f88-49e7-b6bb-213b4455ab66/iso-9361-2-2011>

8 Measurement

Annex A indicates the methods of measuring the dimension m of the indexable inserts covered by this part of ISO 9361.

9 Recommended dimensions

9.1 General

The choice of the more common dimensions is restricted to the values given in Tables 3 to 7. It is strongly recommended that these standard inserts be used each time wherever possible (first preference). When other inserts are required, their dimensions shall be selected from the non-shaded areas of Table B.1 (second preference). Inserts corresponding to the dimensions given in the shaded areas of this table are not recommended.

NOTE The m dimensions are calculated using the exact values, rounded off to the third decimal point, of the corner radius, r_{ϵ} , in accordance with Table 2.

Table 2 — Values of r_{ϵ} used for calculation of dimension m

Designation of r_{ϵ}	04	08	12	16	20	24
Calculation value of r_{ϵ} , mm	0,397	0,794	1,191	1,588	1,984	2,381

9.2 Triangular inserts

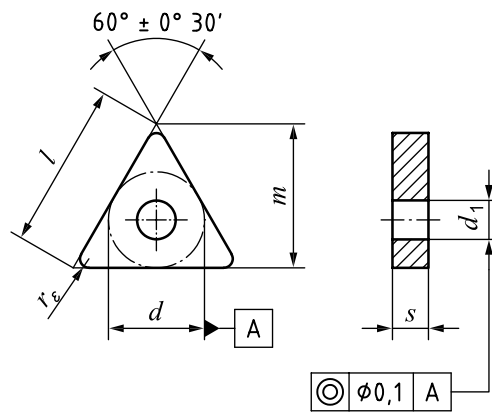

Figure 3 — Triangular inserts

Table 3 — Dimensions of triangular inserts

Dimensions in millimetres

Insert	l	d	s	m	r_ϵ	d_1
TN.A160404	16,5	9,525	4,76	13,891	0,4	3,81
TN.A160408				13,494	0,8	
TN.A160412				13,097	1,2	
TN.A160416				12,7	1,6	
TN.A220608	22	12,7	6,35	18,256	0,8	5,16
TN.A220612				17,859	1,2	
TN.A220616				17,463	1,6	
TN.A220620				17,066	2	

9.3 Square inserts

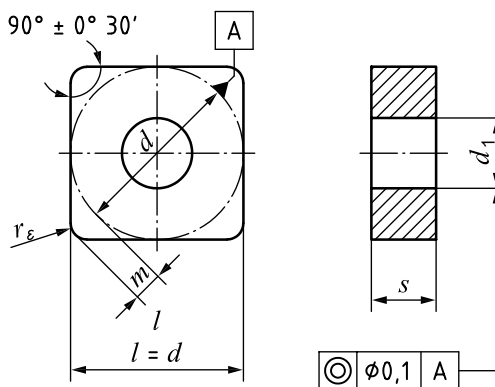

Figure 4 — Square inserts

Table 4 — Dimensions of square inserts

Dimensions in millimetres

Insert	d	s	m	r_ε $\pm 0,1$	d_1 $\pm 0,08$
SN.A120404	12,7	4,76	2,466	0,4	5,16
SN.A120408			2,301	0,8	
SN.A120412			2,137	1,2	
SN.A120416			1,972	1,6	
SN.A120608	12,7	6,35	2,031	0,8	5,16
SN.A120612			2,137	1,2	
SN.A120616			1,972	1,6	
SN.A120620			1,808	2	
SN.A150612	15,875	6,35	2,795	1,2	6,35
SN.A150616			2,63	1,6	
SN.A150620			2,466	2	

9.4 Rhombic inserts with 80° included angle

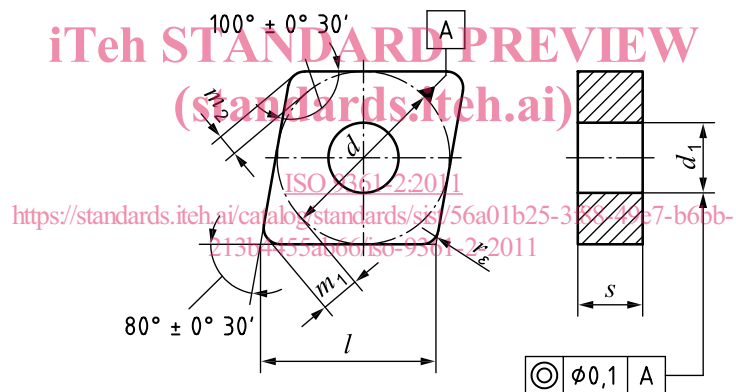

Figure 5 — Rhombic inserts with 80° included angle