



Designation: G38 – 01(Reapproved 2007)

Standard Practice for Making and Using C-Ring Stress-Corrosion Test Specimens¹

This standard is issued under the fixed designation G38; the number immediately following the designation indicates the year of original adoption or, in the case of revision, the year of last revision. A number in parentheses indicates the year of last reapproval. A superscript epsilon (ϵ) indicates an editorial change since the last revision or reapproval.

This standard has been approved for use by agencies of the Department of Defense.

1. Scope

1.1 This practice covers the essential features of the design and machining, and procedures for stressing, exposing, and inspecting C-ring type of stress-corrosion test specimens. An analysis is given of the state and distribution of stress in the C-ring.

1.2 Specific considerations relating to the sampling process and to the selection of appropriate test environments are outside the scope of this practice.

1.3 The values stated in SI units are to be regarded as standard. The values given in parentheses are for information only.

1.4 *This standard does not purport to address all of the safety concerns, if any, associated with its use. It is the responsibility of the user of this standard to establish appropriate safety and health practices and determine the applicability of regulatory limitations prior to use.*

2. Referenced Documents

2.1 NACE Document:

NACE TM0177–96 Laboratory Testing of Metals for Resistance to Sulfide Stress Cracking and Stress Corrosion Cracking in H₂S Environments²

3. Summary of Practice

3.1 This practice involves the preparation of and the quantitative stressing of a C-ring stress-corrosion test specimen by application of a bending load. Characteristics of the stress system and the distribution of stresses are discussed. Guidance is given for methods of exposure and inspection.

4. Significance and Use

4.1 The C-ring is a versatile, economical specimen for quantitatively determining the susceptibility to stress-corrosion

cracking of all types of alloys in a wide variety of product forms. It is particularly suitable for making transverse tests of tubing and rod and for making short-transverse tests of various products as illustrated for plate in Fig. 1.

5. Sampling

5.1 Test specimens shall be taken from a location and with an orientation so that they adequately represent the material to be tested.

5.2 In testing thick sections that have a directional grain structure, it is essential that the C-ring be oriented in the section so that the direction of principal stress (parallel to the stressing bolt) is in the direction of minimum resistance to stress-corrosion cracking. For example, in the case of aluminum alloys (1),³ this is the short-transverse direction relative to the grain structure. If the ring is not so oriented it will tend to crack off-center at a location where the stress is unknown.

6. Specimen Design

6.1 Sizes for C-rings may be varied over a wide range, but C-rings with an outside diameter less than about 16 mm ($\frac{5}{8}$ in.) are not recommended because of increased difficulties in machining and decreased precision in stressing. The dimensions of the ring can affect the stress state, and these considerations are discussed in Section 7. A typical shop drawing for the manufacture of a C-ring is shown in Fig. 2.

7. Stress Considerations

7.1 The stress of principal interest in the C-ring specimen is the circumferential stress. It should be recognized that this stress is not uniform (2, 3). First, there is a gradient through the thickness, varying from a maximum tension on one surface to a maximum compression on the opposite surface. Secondly, the stress varies around the circumference of the C-ring from zero at each bolt hole to a maximum at the middle of the arc opposite the stressing bolt; the nominal stress is present only along a line across the ring at the middle of the arc. Thus, when the specimen is stressed by measuring the strain on the tension surface of the C-ring, the strain gage should be positioned at

¹ This practice is under the jurisdiction of ASTM Committee G01 on Corrosion of Metals and is the direct responsibility of Subcommittee G01.06 on Environmentally Assisted Cracking.

Current edition approved May 1, 2007. Published May 2007. Originally approved in 1973. Last previous edition approved in 2001 as G38-01. DOI: 10.1520/G0038-01R07.

² Available from National Association of Corrosion Engineers (NACE), P.O. Box 218340, Houston, TX 77218–8340.

³ The boldface numbers in parentheses refer to the list of references at the end of this practice.

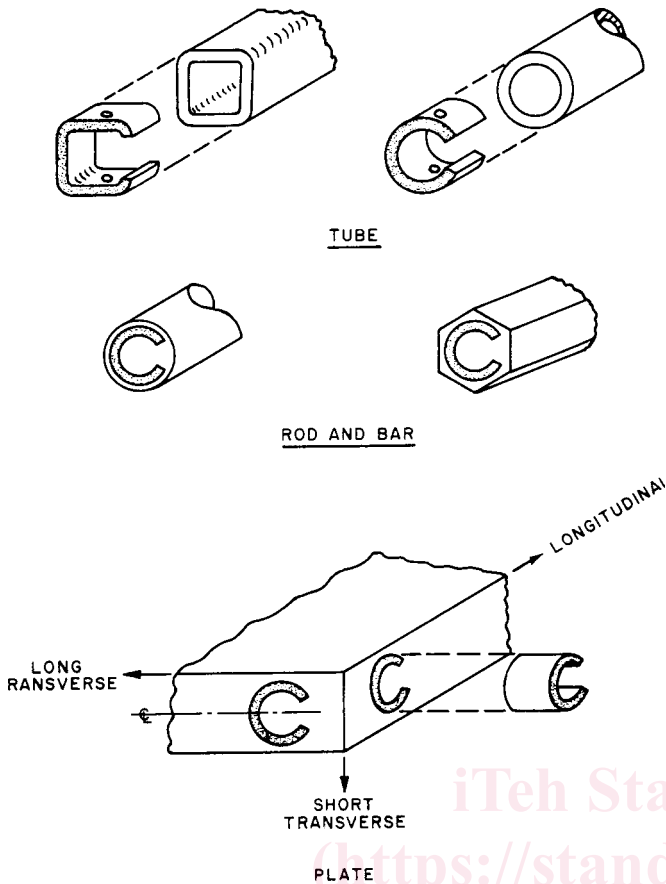

FIG. 1 Sampling Procedure for Testing Various Products

the middle of the arc in order to indicate the maximum strain. Thirdly, the circumferential stress may vary across the width of the ring, the extent of the variation depending on the width-to-thickness and diameter-to-thickness ratios of the C-ring. In general, when loaded as shown in Fig. 3 (a, b), the tensile stress on the outer surface will be greater at the extreme edge than at the center, while when loaded as shown in Fig. 3 (c), the tensile stress on the inner surface will be less at the edge than at the center (4).

7.2 Another characteristic of the stress system in the C-ring is the presence of biaxial stresses; that is, transverse as well as circumferential stresses are developed on the critical test section. The transverse stress will vary from a maximum at the mid-width to zero at the edges, and will be the same sign as the circumferential stress. In general, the transverse stress may be expected to decrease with decreasing width to thickness and increasing diameter to thickness ratios. An example is shown in Fig. 4 where the transverse tensile stress at the mid-width of a 19.00 mm (0.748 in.) outside diameter by 1.537 mm (0.0605 in.) thick by 19.0 mm (0.75 in.) wide C-ring of aluminum alloy 7075-T6 was equal to about one third of the circumferential tensile stress. In this example the circumferential stress was uniform over most of the width of the C-ring; measurements were not made at the extreme edge.

7.3 In the case of the notched C-ring (Fig. 3(d)) a triaxial stress state is present adjacent to the root of the notch (5). In addition, the circumferential stress at the root of the notch will

be greater than the nominal stress and generally may be expected to be in the plastic range.

7.4 The possibility of residual stress should always be considered, especially when C-rings are machined from products that contain appreciable residual stress or when C-rings over about 6.35 mm (1/4 in.) thick are heat treated after being machined. It is generally not advisable to heat treat finish-machined C-rings because of the likelihood of developing residual stresses in the ring.

NOTE 1—When specimens are exposed to corrosive media at elevated temperatures, the possibility of relaxation of stress during the exposure period should be investigated. Relaxation can be estimated from known creep data for both the ring and the stressing bolt.

7.5 An advantage of the C-ring is that it can be stressed with high precision and bias by application of a measured deflection. The sources of error in stressing are those that are inherent with the use of measuring instruments (micrometers, strain gages, etc.) as discussed in 7.2-7.4 and Annex A1.

7.6 The calculated stress applies only to the state of stress before initiation of cracks. Once cracking has initiated the stress at the tip of the crack, as well as in uncracked areas, has changed.

8. Stressing Methods

8.1 The C-ring, as generally used, is a constant-strain specimen with tensile stress produced on the exterior of the ring by tightening a bolt centered on the diameter of the ring. However, a nearly constant load can be developed by the use of a calibrated spring placed on the loading bolt. C-rings also can be stressed in the reverse direction by spreading the ring and creating a tensile stress on the inside surface. These methods of stressing are illustrated in Fig. 3. Proper choice of a minimum bolt diameter or a spring constant is, of course, required to assure achieving true constant strain or constant load stressing.

8.2 The most accurate stressing procedure is to attach circumferential and transverse electrical strain gages to the surface stressed in tension and to tighten the bolt until the strain measurements indicate the desired circumferential stress. The circumferential (σ_C) and transverse (σ_T), stresses are calculated as follows:

$$\sigma_C = E/(1 - \mu^2) \cdot (\epsilon_C + \mu \epsilon_T), \text{ and}$$

$$\sigma_T = E/(1 - \mu^2) \cdot (\epsilon_T + \mu \epsilon_C)$$

where:

- E = Young's modulus of elasticity,
- μ = Poisson's ratio,
- ϵ_C = circumferential strain, and
- ϵ_T = transverse strain.

NOTE 2—When using electrical strain gages with thin-walled C-rings, a correction should be allowed for the displacement of the gage from the surface of the ring. All traces of the gage and the adhesive must be removed from the C-ring before it is exposed.

NOTE 3—Stresses may be calculated from measured strains using the modulus of elasticity, provided the stresses and strains do not exceed the proportional limit.

8.3 When several rings of the same alloy and dimensions are to be loaded, it is convenient to determine a calibration

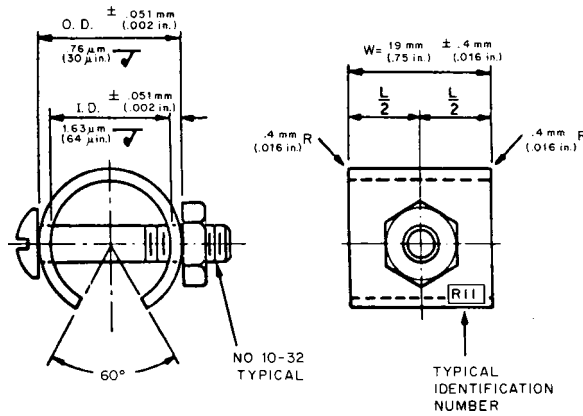

NOTE 1—If stock is undersize or tube stock is used dimensions can be varied to suit size of section from which the specimen must be cut.

FIG. 2 C-Ring Type of Stress-Corrosion Specimen

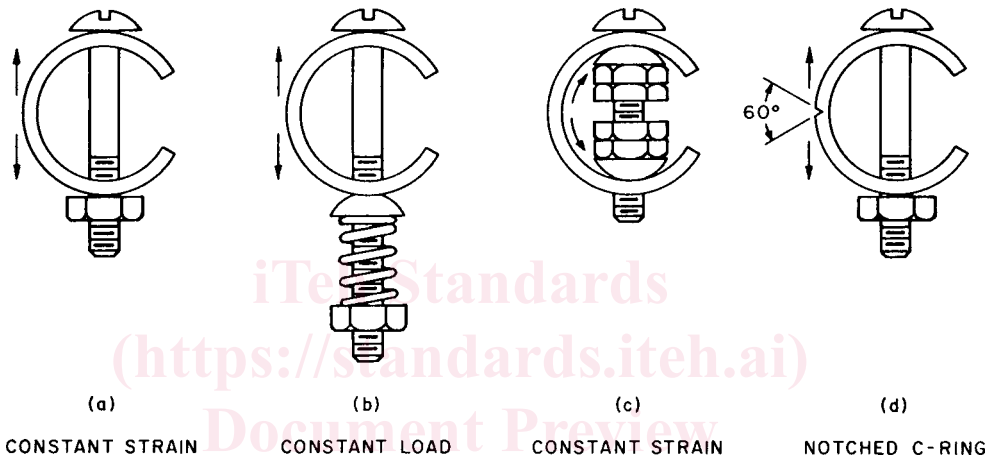

NOTE 1—For Fig 3 (d) a similar notch could be used on the tension side of (b) or (c).

FIG. 3 Methods of Stressing C-Rings

curve of circumferential stress versus ring deflection as in Fig. 4 to avoid the inconvenience of strain gaging each ring.

8.4 The amount of compression required on the C-ring to produce elastic straining only, and the degree of elastic strains can be predicted theoretically (2, 3). Therefore, C-rings may be stressed by calculating the deflection required to develop a desired elastic stress by using the individual ring dimensions in a modified curved beam equation as shown in Table A1.1. The accuracy of calculated stresses is shown in Fig. 4 by the agreement of the calculated curve and the actual data points. See Annex A1 for the equation for stressing C-ring specimens.

8.5 In the case of notched specimens a nominal stress is assumed using the ring outside diameter measured at the root of the notch. Consideration then should be given to the stress concentration factor (K_T) for the specific notch when calculating the Δ required to develop the intended stress.

NOTE 4—The National Association of Corrosion Engineers (NACE) Standard TM0177-96 provides procedures for stressing C-Rings to the 0.2% offset yield strength of the material to be tested. Experimentation under the review and scrutiny of the ASTM subcommittee holding jurisdiction of this standard was conducted to assess the accuracy and validity of such procedures. It was found that for a wide range of alloy systems, heat treatments, and test specimen dimensions, errors in the target strain associated with the 0.2% offset yield strength occurred which

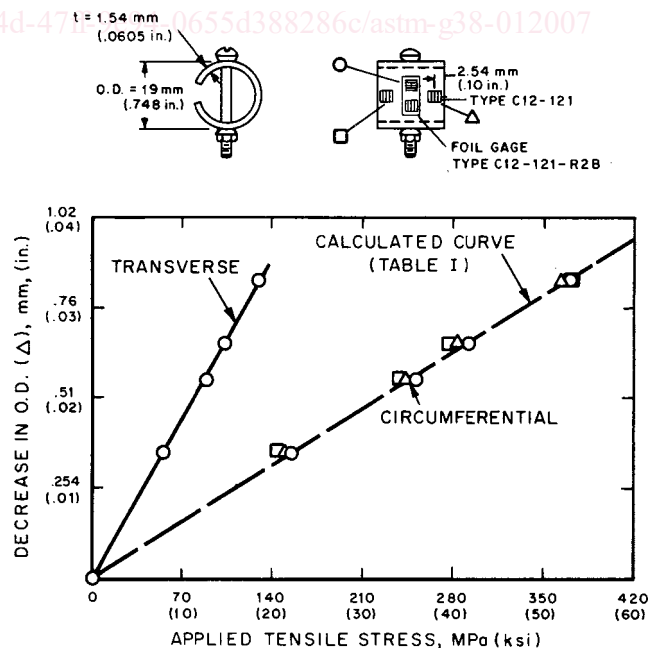
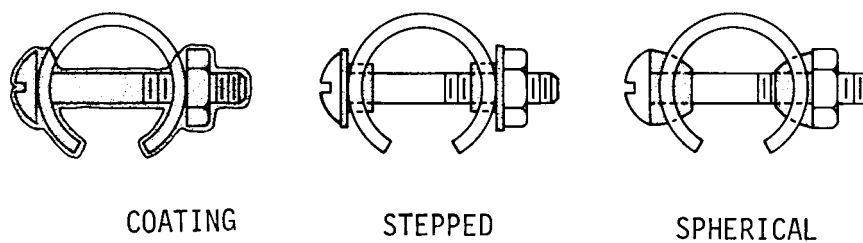

FIG. 4 Stresses in 7075-T6 Aluminum Alloy C-Ring Stress-Corrosion Specimen (4)



INSULATING BUSHINGS

FIG. 5 Protection Against Galvanic Effects

would be of significance. However, it was also determined that in all cases the actual strain realized following the procedures exceeded that associated with the 0.2% offset yield stress, rendering results following such procedures conservative from an engineering analysis standpoint.

9. Machining

9.1 When rings are machined from solid stock, precautions should be taken to avoid practices that overheat, plastically deform, or develop residual stress in the metal surface. Machining should be done in stages so that the final cut leaves the principal surface with a clean finish of 0.7 μm (30 $\mu\text{in.}$) rms or better. Necessary machining sequences, type of tool, feed rate, etc., depend upon the alloy and temper of the test piece. Lapping, mechanical polishing, and similar operations that produce flow of the metal should be avoided.

10. Surface Preparation

10.1 A high-quality machined surface is the most desirable for corrosion test purposes unless one wants to test the as-fabricated surface of a tube or bar; it should, of course, be degreased before exposing the specimen. In order to remove heat treat films or thin layers of surface metal that may have become distorted during machining, chemical or electrochemical etches may be used. The choice of such a treatment will depend upon the alloy of the test piece. Care should be exercised to choose an etchant that will not selectively attack constituents in the metal or will not deposit undesirable residues on the surface. Etching or pickling should not be used for alloys that may undergo hydrogen embrittlement.

10.2 It is generally the best procedure to complete the surface preparation before the C-ring is stressed except for a possible final degreasing of the critically stressed area.

10.3 Every precaution should be taken to maintain the integrity of the surface after the final preparation; that is, avoid finger printing and any rough handling that could mar the finish.

11. Specimen Identification

11.1 Specimen numbers may be scribed on one of the tips adjacent to the cut-away segment of the C-ring. No markings of any kind should be made on the critically stressed arc between the bolt holes. Nonmetallic tags may be attached to the stressing bolt by means of a second nut.

12. Exposure Methods

12.1 The C-ring, because of its small size and the simple methods of stressing, can be exposed to almost any kind of

corrosive environment (6). The specimens should be supported in such a way that nothing except the corrosive medium comes in contact with the critically stressed area. No part of an exposure rack should be allowed to touch the surface or the edges of the critically stressed region.

12.2 Care must be exercised to avoid galvanic effects between the C-ring, the stressing bolt, and exposure racks. It is essential also to prevent crevice corrosion that could develop corrosion products between ring and bolt and alter the stress in the C-ring. Protection can readily be applied by means of suitable coatings or by insulating bushing as shown in Fig. 5. Consideration must be given to the selection of coatings or insulators that will neither contaminate the corroding medium nor be deteriorated by it. An insulating bushing, for example, that would deteriorate or creep, and thus allow the stress in the specimen to decrease, would be unsatisfactory.

NOTE 5—Specimens should be placed in the intended corrosive environment as soon as possible after being stressed, as some alloys may crack in moderately humid air.

NOTE 6—Hemispheric glazed ceramic insulators (S-151 Steatite) are excellent for use outdoors and in neutral aqueous solutions.⁴ Beeswax, and other adherent wax-type coatings, are suitable for room temperature tests in aqueous solutions. For tests in acidic or alkaline solutions, fast drying vinyl-type lacquers have been used successfully; an example is an electroplaters stop-off.⁵

12.3 Determination of cracking time is a subjective procedure involving visual examination that under some conditions can be very difficult, as noted in Section 13, and depends on the skill and experience of the inspector.

13. Inspection

13.1 Highly stressed C-rings of alloys that are appreciably susceptible to stress-corrosion cracking tend to fracture through the entire thickness or to crack in a way that is conspicuous. Frequently, however, with lower applied stresses, or with more stress-corrosion-resistant alloys, cracking begins

⁴ The sole source of supply of the apparatus known to the committee at this time is Saxonburg Ceramics, Inc., P. O. Box 157, Saxonburg, PA 16056. If you are aware of alternative suppliers, please provide this information to ASTM International Headquarters. Your comments will receive careful consideration at a meeting of the responsible technical committee,¹ which you may attend.

⁵ The sole source of supply of the apparatus known to the committee at this time is "Micro Shield," available from the Michigan Chrome and Chemical Co., Dept. T-R, 8615 Grinnell Ave., Detroit, MI 48213. If you are aware of alternative suppliers, please provide this information to ASTM International Headquarters. Your comments will receive careful consideration at a meeting of the responsible technical committee,¹ which you may attend.