



Designation: D3603 – 07

Standard Test Method for Rust-Preventing Characteristics of Steam Turbine Oil in the Presence of Water (Horizontal Disk Method)¹

This standard is issued under the fixed designation D3603; the number immediately following the designation indicates the year of original adoption or, in the case of revision, the year of last revision. A number in parentheses indicates the year of last reapproval. A superscript epsilon (ϵ) indicates an editorial change since the last revision or reapproval.

1. Scope

1.1 This test method covers the ability of steam-turbine oils to prevent the rusting of horizontal and vertical ferrous surfaces when water becomes mixed with the oil.

1.2 The values stated in SI units are to be regarded as standard. The values given in parentheses are for information only.

1.3 *This standard does not purport to address all of the safety concerns, if any, associated with its use. It is the responsibility of the user of this standard to establish appropriate safety and health practices and determine the applicability of regulatory limitations prior to use.*

2. Referenced Documents

2.1 ASTM Standards:²

A108 Specification for Steel Bar, Carbon and Alloy, Cold-Finished

A240/A240M Specification for Chromium and Chromium-Nickel Stainless Steel Plate, Sheet, and Strip for Pressure Vessels and for General Applications

D91 Test Method for Precipitation Number of Lubricating Oils

D665 Test Method for Rust-Preventing Characteristics of Inhibited Mineral Oil in the Presence of Water

D1193 Specification for Reagent Water

E1 Specification for ASTM Liquid-in-Glass Thermometers

2.2 Other Standards:

IP 60/80 Specification for Petroleum Spirit³

SAE 30304 Steel, Corrosion-Resistant, Sheet, Strip, and

Plate, 19Cr - 9.2Ni⁴

BS 970:Part 1:1983 Specification for wrought steels for mechanical and allied engineering purposes. General inspection and testing procedures and specific requirements for carbon, carbon manganese, alloy and stainless steels⁵

BS 871:1981 Specification for abrasive papers and cloths

3. Summary of Test Method

3.1 The test method involves completely immersing a horizontal steel disk and vertical steel cylinder in a stirred mixture of 275 mL of the oil under test and 25 mL of distilled water (water conforming to Specification D1193, Type II) at a temperature at 60°C (140°F).

3.2 The horizontal specimen allows water to puddle on the surface, and the vertical specimen is continually washed with the oil-water mixture during the test.

3.3 The test is run for 6 h and the specimens are evaluated.

4. Significance and Use

4.1 Horizontal metal surfaces, on which water droplets tend to be retained, are more prone to rusting and corrosion than vertical or sloping surfaces. This test method is therefore more discriminating than Test Method D665 (Procedure A), since it gives a separate evaluation of the oil on a horizontal and a vertical surface. The test method indicates the ability of oils to prevent rusting and corrosion of all ferrous surfaces in steam turbines under full flow and quasi-static conditions. It is used for specification of new oils.

5. Apparatus

5.1 *Oil Bath*—A thermostatically controlled liquid bath capable of maintaining a temperature in the oil sample of $60 \pm 1^\circ\text{C}$ ($140 \pm 2^\circ\text{F}$). The bath shall have a cover with holes to accommodate the test beakers.

NOTE 1—The bath used for Test Method D665 may be used with slight modification, that is, the centers of the beaker holes are moved from 6.4 mm to 18.3 mm ($1/4$ to $23/32$ in.) from the axes of the stirrers.

⁴ Available from SAE World Headquarters, 400 Commonwealth Drive, Warrendale, PA 15096-0001.

⁵ BSI, British Standards, 389 Chiswick High Road, London W4 4AL, United Kingdom.

¹ This test method is under the jurisdiction of ASTM Committee D02 on Petroleum Products and Lubricants and is the direct responsibility of D02.C0.02 on Corrosion and Water/Air Separability.

Current edition approved May 1, 2007. Published May 2007. Originally approved in 1977. Last previous edition approved in 2002 as D3603-93(2002). DOI: 10.1520/D3603-07.

² For referenced ASTM standards, visit the ASTM website, www.astm.org, or contact ASTM Customer Service at service@astm.org. For *Annual Book of ASTM Standards* volume information, refer to the standard's Document Summary page on the ASTM website.

³ Available from Energy Institute, 61 New Cavendish St., London, WIG 7AR, U.K., <http://www.energyinst.org.uk>.

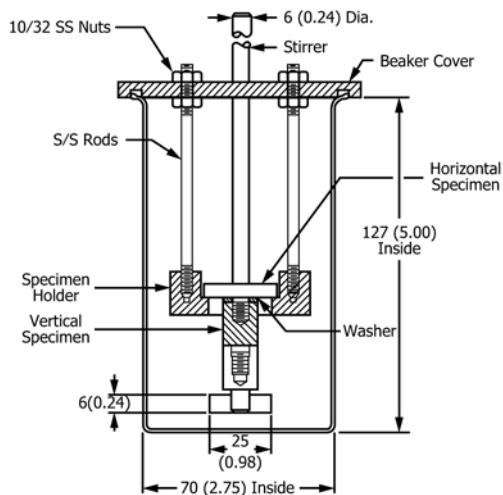

NOTE 1—All dimensions are in millimetres (inches).
FIG. 1 Rusting Test Apparatus

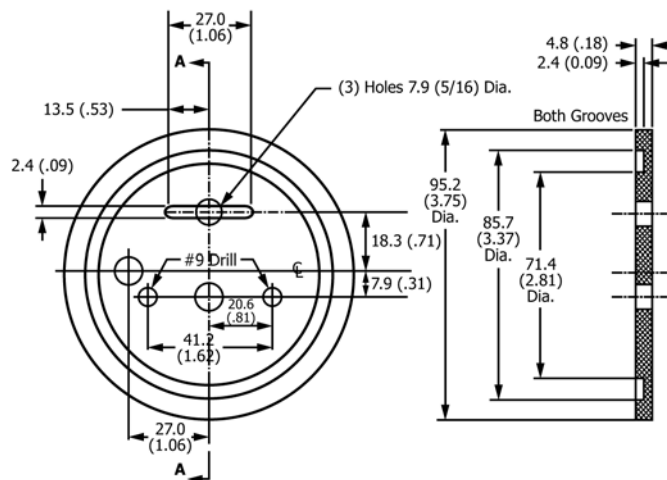

NOTE 1—All dimensions are in millimetres (inches).
FIG. 2 Beaker Cover

NOTE 2—To indicate the temperature, a thermometer conforming to the requirements of ASTM Thermometer 9C or 9F, or IP Thermometer 21C, as prescribed in Specification E1 should be used.

5.2 *Beaker*—A 400-mL, Berzelius-type, tall-form heat-resistant glass⁶ beaker without pourout, as shown in Fig. 1, approximately 127 mm (5 in.) in height measured from the inside bottom center and approximately 70 mm (2¾ in.) in inside diameter measured at the middle.

5.3 *Beaker Cover and Specimen Holder*—A flat beaker cover (Fig. 2) of methyl methacrylate resin or other fluid resistant material is kept in position by a suitable groove. Three holes are provided. Two are located on any diameter of the cover, one for a stirrer, and the other for attachment of a disk specimen to the underside of the cover for optional vapor phase testing. The third hole is for a thermometer, located on a diameter perpendicular to that of the other two holes. The outside of the polytetrafluoroethylene (PTFE) specimen holder (Fig. 3) is a square, but from the ends of one diagonal, two equal pieces of PTFE are cut off over the height of the holder. Two vertical threaded holes are made on the other diagonal of the square. The inside of the holder consists of two cylindrical holes, one on top of the other. Four horizontal holes are drilled 90° apart on the circumference where the two cylindrical holes meet. The PTFE specimen holder is connected to the beaker cover by two stainless steel holding rods (Fig. 4). Both ends of each holding rod are threaded. The surfaces between the threads are polished with No. 180 grit emery. The 12.7-mm threaded ends of the holding rods are screwed into the two vertical threaded holes of the specimen holder. The 19.0-mm threaded ends of the holding rods are connected to the beaker cover by putting them through two holes on a line perpendicular to the connection line of the centers of the earlier mentioned first and second hole of the beaker cover. Each holding rod is fastened by two 10-32 stainless steel nuts.

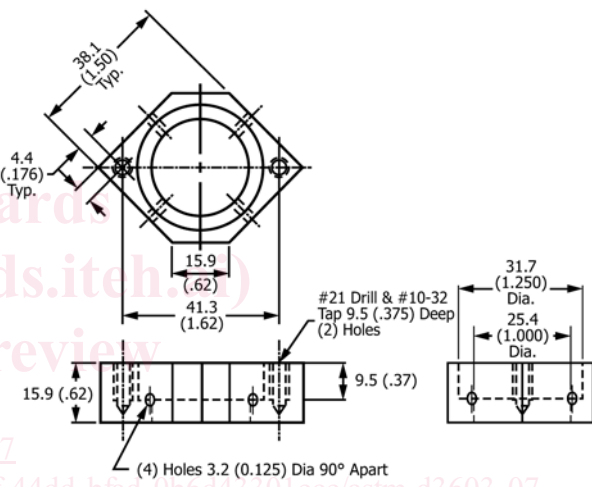

NOTE 1—All dimensions are in millimetres (inches).
FIG. 3 Specimen Holder

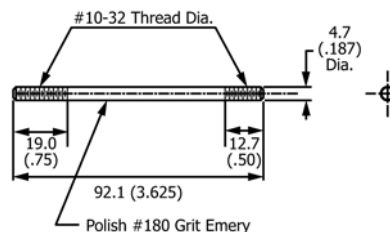

NOTE 1—All dimensions are in millimetres (inches).
FIG. 4 Holding Rod

5.4 *Stirrer*—A stirrer constructed entirely from stainless steel in the form of an inverted T (Fig. 5). A flat blade 25.4 by 6.1 by 0.6 mm (1 by 0.24 by 0.024 in.) shall be attached to a 6.1-mm (0.24-in.) rod in such a way that the blade is symmetrical with the rod and has its flat surface in the vertical plane.

NOTE 4—A suitable material is an 18 % chromium, 8 % nickel alloy steel conforming to Type 304 of ASTM Specification A240/A240M or SAE No. 30304, or BS 970: Part I:1983:302531.

⁶ Borosilicate glass is satisfactory for this purpose.

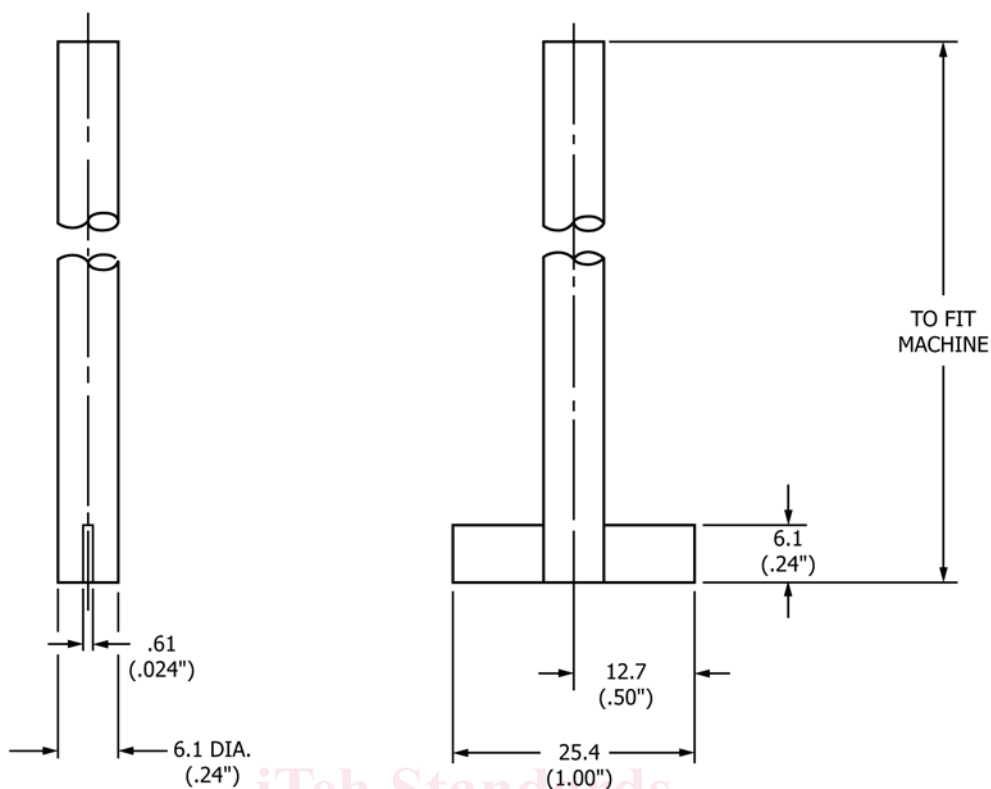

NOTE 1—All dimensions are in millimetres (inches).

NOTE 2—¹²⁵ all over.

NOTE 3—All dimensions ± 0.5 mm (0.02 in.).

NOTE 4—Break all sharp corners.

FIG. 5 Stirrer

NOTE 5—If stainless steel is not obtainable, stirrers made of heat-resistant glass⁶ and having approximately the same dimensions as the stainless steel stirrers may be used.

5.5 *Stirring Apparatus*—Any convenient form of stirring apparatus capable of maintaining a speed of 1000 ± 50 r/min.

5.6 *Grinding and Polishing Equipment*—A CAMI 150-grit (99 μ m) and a CAMI 240-grit (53.5 μ m) in accordance with BS 871 or its equivalent, metalworking aluminum oxide abrasive cloth coat on a jeans backing (the corresponding European grades (FEPA) are P150J and P280J, respectively), a suitable chuck (Fig. 6) for holding the specimen, and a means of rotating the specimen at a speed of 1700 to 1800 r/min.

NOTE 6—CAMI (Coated Abrasives Manufacturers Institute) is a United States organization and FEPA (Federations of European Producers of Abrasives) is a European organization.

6. Reagents and Materials

6.1 *Cleaning Agents*—One of the following shall be used:

6.1.1 *ASTM Precipitation Naphtha*, conforming to Test Method D91. (**Warning**—Flammable. Health hazard.)

6.1.2 *Isooctane*, conforming to Annex II on Reference Materials and Blending Accessories (see Annex II, Reference Materials and Blending Accessories, Motor Section⁷). Previ-

ously used, unrusted specimens shall be stored in this reagent. (**Warning**—Flammable. Health hazard.)

6.1.3 *IP Petroleum Spirit*, conforming to IP 60/80. (**Warning**—Flammable. Health hazard.)

7. Test Specimens and Their Preparation

7.1 The horizontal and vertical specimens (Fig. 7 and Fig. 8, respectively) are attached to one another, separated by a 2.4-mm ($\frac{3}{32}$ -in.) fluorocarbon washer (Fig. 9). A methyl methacrylate cap (Fig. 10) is attached to the vertical specimen for handling.

7.2 The horizontal specimen when new shall be 30.2 mm ($1\frac{3}{16}$ in.) in diameter and 4.8 mm ($\frac{3}{16}$ in.) thick, with a 6.4-mm ($\frac{1}{4}$ -in.) central threaded shaft 9.5 mm ($\frac{3}{8}$ in.) long. Specimens should be discarded when they reach a thickness of 1.6 mm ($\frac{1}{16}$ in.) after repeated use.

7.3 The vertical specimen when new shall be 12.7 mm ($\frac{1}{2}$ in.) in diameter and 15.9 mm ($\frac{5}{8}$ in.) in length exclusive of the 9.5-mm ($\frac{3}{8}$ -in.) threaded shaft which screws into the 15.9-mm plastic cap. Specimens should be discarded when they reach a diameter of 9.5 mm after repeated use.

7.4 Both specimens shall be made of steel conforming to Grade 1018 of Specification A108, or to BS 970: 1955-EN3B.

NOTE 7—When making a check test, the steel specimen that showed

⁷ Last printed in the 1996 Annual Book of ASTM Standards, Vol 05.04.