



Designation: D 4365 – 95 (Reapproved 2007)^{e1}

Standard Test Method for Determining Micropore Volume and Zeolite Area of a Catalyst¹

This standard is issued under the fixed designation D 4365; the number immediately following the designation indicates the year of original adoption or, in the case of revision, the year of last revision. A number in parentheses indicates the year of last reapproval. A superscript epsilon (ϵ) indicates an editorial change since the last revision or reapproval.

^{e1} NOTE—Editorial changes were made throughout in April 2007.

1. Scope

1.1 This test method covers the determination of total surface area and mesopore area. From these results are calculated the zeolite area and micropore volume of a zeolite containing catalyst. The micropore volume is related to the percent zeolite in the catalyst. The zeolite area, a number related to the surface area within the zeolite pores, may also be calculated. Zeolite area, however, is difficult to interpret in physical terms because of the manner in which nitrogen molecules pack within the zeolite.

1.2 *This standard does not purport to address all of the safety concerns, if any, associated with its use. It is the responsibility of the user of this standard to establish appropriate safety and health practices and determine the applicability of regulatory limitations prior to use.* For a specific precautionary statement, see [Note 3](#).

2. Referenced Documents

2.1 *ASTM Standards:*²

[D 3663](#) Test Method for Surface Area of Catalysts and Catalyst Carriers

[D 3906](#) Test Method for Determination of Relative X-ray Diffraction Intensities of Faujasite-Type Zeolite-Containing Materials

[E 177](#) Practice for Use of the Terms Precision and Bias in ASTM Test Methods

[E 456](#) Terminology Relating to Quality and Statistics

[E 691](#) Practice for Conducting an Interlaboratory Study to Determine the Precision of a Test Method

3. Terminology

3.1 *Definitions of Terms Specific to This Standard:*

¹ This test method is under the jurisdiction of ASTM Committee D32 on Catalysts and is the direct responsibility of Subcommittee D32.01 on Physical-Chemical Properties.

Current edition approved April 1, 2007. Published May 2007. Originally approved in 1984. Last previous edition approved in 2001 as D 4365-95(2001).

² For referenced ASTM standards, visit the ASTM website, www.astm.org, or contact ASTM Customer Service at service@astm.org. For *Annual Book of ASTM Standards* volume information, refer to the standard's Document Summary page on the ASTM website.

3.1.1 *mesopore area of a catalyst*—the area determined from the slope of the t-plot.

3.1.2 *micropore volume of the catalyst*—the pore volume in pores having radii less than 1 nm, usually associated with the zeolite portion of the catalyst, and determined from the intercept of the t-plot.

3.1.3 *surface area of a catalyst*—the total surface of the catalyst pores. It is expressed in square metres per gram.

3.1.4 *zeolite area of a catalyst*—the difference between total surface area and mesopore area.

3.2 Symbols:

P_{H_1}	= initial helium pressure, torr
P_{H_2}	= helium pressure after equilibration, torr
S_B	= slope of BET plot, 11.7
I_B	= intercept of BET plot, 11.7
S_t	= slope of t-plot, 11.13
I_t	= intercept of t-plot, 11.13
T_{H1}	= temperature of manifold at initial helium pressure, °C
T_{H2}	= temperature of manifold after equilibration, °C
$T_x'(i)$	= extra volume bulb temperature, °C
$T_x(i)$	= extra volume bulb temperature, K
$P_1(i)$	= initial N_2 pressure, torr
$T_1(i)$	= manifold temperature at initial N_2 pressure, K
$T_1'(i)$	= manifold temperature at initial N_2 pressure, °C
$P_2(i)$	= pressure after equilibration, torr
$T_2(i)$	= manifold temperature after equilibration, K
$T_2'(i)$	= manifold temperature after equilibration, °C
$P_0(i)$	= liquid nitrogen vapor pressure, torr
$T_s(i)$	= liquid nitrogen temperature, K
X	= relative pressure, P_2/P_0
V_d	= volume of manifold, cm^3
V_x	= extra volume bulb, cm^3
V_s	= effective void volume, cm^3
W_s	= weight of sample, g
W_1	= tare weight of sample tube, g
W_2	= weight of sample + tare weight of tube, g
V_{ds}	= volume of nitrogen in the dead-space, cm^3
V_1	= see 11.4.3
V_2	= see 11.4.4

V_t	= see 11.4.5
V_a	= see 11.4.7
V_m	= see 11.8
BET (i)	= see 11.4.8
$t(i)$	= see 11.10

4. Summary of Test Method

4.1 The volume of nitrogen gas adsorbed by the catalyst at liquid nitrogen temperature is measured at various low-pressure levels. This is done by measuring pressure differentials caused by introducing a fixed volume of nitrogen to the degassed catalyst in the test apparatus. This procedure is the same as Test Method D 3663, that gives total surface area, but extends the pressure range to permit calculation of micropore volume and matrix surface area, by the t-plot method. Zeolite area is the difference between total area and matrix area.

5. Significance and Use

5.1 This gas adsorption method complements the X-ray procedure of Test Method D 3906. This test method will be useful to laboratories that do not have X-ray diffractometers. Each test method can be calibrated by use of an appropriate series of mechanical mixtures to provide what may be termed percent zeolite. If there is disorder in the zeolite, the adsorption method will yield higher values than the X-ray method. The reverse will be true if some zeolite pores (micropores) are blocked or filled.

6. Apparatus

6.1 A schematic diagram of the apparatus is shown in Fig. 1. It may be constructed of glass or of metal. It has the following features:

6.1.1 *Distribution Manifold*, having a volume between 20 and 35 cm³, (V_d), known to the nearest 0.05 cm³. This volume is defined as the volume between the stopcocks or valves and includes the pressure gage. It is preferred that this volume be thermostatted.

6.1.2 *Vacuum System*, capable of attaining pressures below 10⁻⁴ torr (1 torr = 133.3 Pa). This will include a vacuum gage (not shown in Fig. 1). Access to the distribution manifold is through the valve V.

6.1.3 *Constant-Volume Gage or Mercury Manometer*, capable of measurements to the nearest 0.1-torr sensitivity in the range from 0 to 1000 torr (1 torr = 133.3 Pa).

NOTE 1—See, for example, the article by Joy for a description of a constant-volume manometer.³

6.1.4 *Valve (H)*, from the helium supply to the distribution manifold.

6.1.5 *Valve (N)*, from the nitrogen supply to the distribution manifold.

6.1.6 The connection between the sample tube and the S valve can be a standard-taper glass joint, a glass-to-glass seal, or a compression fitting.

6.1.7 *Extra Volume (EV) Bulb*, may be attached through valve EV. Its volume (V_x) should be 100 to 150 cm³, known to

the nearest 0.05 cm³. V_x includes the volume of the stopcock bore in the glass apparatus. It is preferred that this volume be held at the same temperature as that of the distribution manifold.

NOTE 2—Modern commercial instruments automatically adjust the amounts dosed in order to produce data points at user-selected target pressures. Hence, the use of an EV bulb is optional. Some instruments can analyze multiple samples simultaneously and may use sample tubes with volumes outside of the range specified in this test method.

6.2 *Sample Tubes*, with volumes from 5 cm³ to 25 cm³ depending on the application. Markings should be placed on the sample tubes about 30 to 50 mm below the connectors to indicate the desired liquid nitrogen level.

6.3 *Heating Mantles or Small Furnaces*.

6.4 *Dewar Flasks*.

6.5 *Laboratory Balance*, with 0.1 mg (10⁻⁷ kg) sensitivity.

6.6 *Thermometer*, for measuring the temperature of the distribution manifold, $T_1'(i)$ or $T_2'(i)$, in degrees Celsius.

6.7 *Thermometer*, for measuring the temperature of the liquid nitrogen bath $T_s(i)$ in kelvins. This will preferably be a nitrogen vapor-pressure-thermometer that gives P_0 directly and has greater precision, or a resistance thermometer from which P_0 values may be derived.

6.8 *Thermometer*, for measuring the temperature of the EV bulb, $T_x'(i)$, if different from $T_1'(i)$ or $T_2'(i)$.

7. Reagents

7.1 *Purity of Reagents*—Reagent grade chemicals shall be used in all tests. Unless otherwise indicated, it is intended that all reagents shall conform to the specifications of the Committee on Analytical Reagents of the American Chemical Society, where such specifications are available.⁴ Other grades may be used, provided it is first ascertained that the reagent is of sufficiently high purity to permit its use without lessening the accuracy of the determination.

7.2 *Helium Gas*—A cylinder of helium gas at least 99.9 % pure.

7.3 *Liquid Nitrogen*, of such purity that P_0 is not more than 20 torr above barometric pressure. A fresh daily supply is recommended.

7.4 *Nitrogen Gas*—A cylinder of nitrogen gas at least 99.9 % pure.

8. Procedure—Sample Preparation and Degassing

8.1 Select a sample tube of the desired size. A 5-cm³ sample tube is preferred for samples not exceeding about 1 g, to minimize the dead-space. However, a 25-cm³ sample tube may be preferred for finely powdered catalysts, to avoid “boiling” when degassing is started.

⁴ *Reagent Chemicals, American Chemical Society Specifications*, American Chemical Society, Washington, DC. For suggestions on the testing of reagents not listed by the American Chemical Society, see *Analar Standards for Laboratory Chemicals*, BDH Ltd., Poole, Dorset, U.K., and the *United States Pharmacopeia and National Formulary*, U.S. Pharmacopeial Convention, Inc. (USPC), Rockville, MD.

³ Joy, A. S., *Vacuum*, Vol 3, 1953, p. 254.

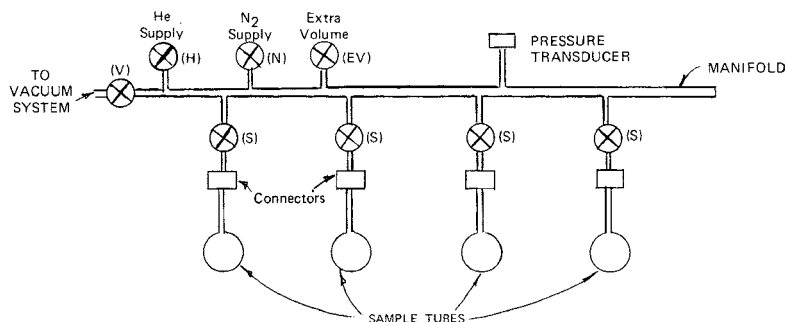

FIG. 1 Schematic Diagram of Surface Area Apparatus

8.2 Fill the sample tube with nitrogen or helium, at atmospheric pressure, after removing air by evacuation. This may be done on the surface area unit, or on a separate piece of equipment.

8.3 Remove the sample tube from the system, cap, and weigh. Record the weight as W_1 .

8.4 Place the catalyst sample, of which the weight is known approximately, into the sample tube. Choose the sample size to provide an estimated total sample surface area of 20 to 100 m^2 .

8.5 Attach the sample tube to the apparatus. If other samples are to be run, attach them at this time to the other ports.

8.6 Open the S valves where there are samples.

8.7 Slowly open the V valve, monitoring the rate of pressure decrease to avoid too high a rate, which could lead to excessive fluidization of powdered samples.

8.7.1 It may be necessary to close the V valve system periodically to protect the diffusion pump fluid from exposure to pressures above 0.1 torr for periods of more than 30 s. Close the valve off for 2 min each time.

8.8 Install a heating mantle or furnace around each sample and raise the temperature to about 300°C (573 K).

NOTE 3—Take special precautions if the moisture content exceeds approximately 5 % to avoid “bumping” of powdered catalyst, and to avoid surface area loss by self-steaming. It is recommended that the heating rate not exceed 100°C(K)/h under these circumstances.

8.9 Continue degassing at about 300°C (573 K) for a minimum of 3 h, at a pressure not to exceed 10^{-3} torr. Overnight degassing is permissible.

NOTE 4—Zeolite-containing catalysts may contain large quantities of water. Pretreatment of the sample in an oven at 400°C in flowing nitrogen for a couple of hours may be desirable.

8.10 Remove the heating mantles, and allow the samples to cool.

8.11 Close the EV valve, if open.

8.12 Close the S valve.

8.13 It is permissible to exercise the option of preliminary degassing on an external unit. In such a case, follow the procedures of 8.4-8.11 and then repeat on the surface area unit, except that the degassing time in 8.9 should not exceed 1 h.

8.14 If it is desired to weigh the sample after preliminary degassing on an external unit, backfill with the same gas used in 8.2 to above atmospheric pressure. Close the S valve. Otherwise, use the weight obtained in 10.18 and omit 8.15.

8.15 Detach the sample tube from the apparatus, recap with the stopper used previously, and weigh. Record the weight as W_2 .

8.16 Remove the backfilled gas by evacuation to less than 10^{-4} torr at room temperature.

9. Procedure—Dead-Space Determination

9.1 From this point on, each sample being tested for micropore volume and surface area must be run on an individual basis. Thus, each Step 9.2-10.17 must be carried out separately for each tube in test.

9.2 The “dead-space” is the void volume of the charged sample tube, including the volume within the S valve, when the tube is immersed in liquid nitrogen to the proper depth.

NOTE 5—The dead-space may be determined after the nitrogen adsorption, if more convenient, so long as adequate degassing precedes its determination. In that case, replace the liquid nitrogen bath after 10.14 before proceeding with 9.3-9.9. Then, remove the Dewar flask before carrying out 10.15-10.17.

9.3 Place a Dewar flask of liquid nitrogen around the sample and adjust the liquid level to a fixed point on the sample tube. Maintain this level throughout the test.

9.4 Zero the pressure gage.

9.5 Admit the helium gas into the system to a pressure of 600 to 900 torr by carefully opening the H valve. With H valve closed, record this pressure, P_{H_1} , and the manifold temperature, T_{H_1} .

9.6 Open the S valve to admit helium to the sample.

9.7 After about 5 min of equilibration, readjust the liquid nitrogen level, and record the pressure, P_{H_2} , and the manifold temperature, T_{H_2} .

9.8 Repeat 9.5-9.7 for each sample cell attached to the manifold.

9.9 Open all S valves; then slowly open the V valve to remove the helium gas.

9.10 When a pressure less than 0.01 torr has been attained, close the S valve. This operation should take 5 to 10 min.

10. Procedure—Nitrogen Adsorption

10.1 Close the V valve and open the EV valve. (The extra volume bulb should be thermostatted at a particular temperature, a few degrees above ambient.)

10.2 Recheck the zero setting of the pressure gage.

10.3 Admit nitrogen gas, and record the pressure as $P_1(1)$ (torr) and the temperature as $T_1'(1)$ (degrees Celsius). It is