

---

---

**Rotary shaft lip-type seals incorporating  
thermoplastic sealing elements —**

**Part 4:  
Performance test procedures**

*Bagues d'étanchéité à lèvres pour arbres tournants incorporant des  
éléments d'étanchéité thermoplastiques —*

*Partie 4: Modes opératoires des essais de performance*

iTeh STANDARD PREVIEW  
(standards.iteh.ai)

ISO 16589-4:2011

<https://standards.iteh.ai/catalog/standards/sist/a0945f75-cd42-4a2e-a24b-188a03cf09b0/iso-16589-4-2011>



## iTeh STANDARD PREVIEW (standards.iteh.ai)

ISO 16589-4:2011

<https://standards.iteh.ai/catalog/standards/sist/a0945f75-cd42-4a2e-a24b-188a03cf09b0/iso-16589-4-2011>



### **COPYRIGHT PROTECTED DOCUMENT**

© ISO 2011

All rights reserved. Unless otherwise specified, no part of this publication may be reproduced or utilized in any form or by any means, electronic or mechanical, including photocopying and microfilm, without permission in writing from either ISO at the address below or ISO's member body in the country of the requester.

ISO copyright office  
Case postale 56 • CH-1211 Geneva 20  
Tel. + 41 22 749 01 11  
Fax + 41 22 749 09 47  
E-mail [copyright@iso.org](mailto:copyright@iso.org)  
Web [www.iso.org](http://www.iso.org)

Published in Switzerland

# Contents

Page

Foreword .....	iv
Introduction.....	v
<b>1 Scope .....</b>	<b>1</b>
<b>2 Normative references .....</b>	<b>1</b>
<b>3 Terms and definitions .....</b>	<b>2</b>
<b>4 Pre-test procedure.....</b>	<b>2</b>
<b>5 Dynamic normal temperature test .....</b>	<b>2</b>
5.1 Test apparatus .....	2
5.2 Installation.....	4
5.3 Test conditions .....	5
5.4 Test procedure.....	5
5.5 Post-test measurements.....	5
5.6 Recording.....	5
5.7 Acceptance criteria .....	5
<b>6 Dynamic low temperature test .....</b>	<b>5</b>
6.1 General .....	5
6.2 Test apparatus .....	5
6.3 Installation.....	6
6.4 Test procedure.....	6
6.5 Post-test measurements.....	7
6.6 Recording.....	7
6.7 Acceptance criteria .....	7
<b>7 Material testing of the rotary shaft seal components .....</b>	<b>7</b>
7.1 General .....	7
7.2 Metallic components (cases) .....	7
7.3 Non-metallic components.....	7
7.3.1 Thermoplastic sealing elements.....	7
7.3.2 Elastomeric sealing elements — gaskets, protection lip and sealant.....	7
<b>8 Identification statement (Reference to this part of ISO 16589).....</b>	<b>7</b>
<b>Annex A (informative) Typical example of seal test report for the dynamic normal temperature test .....</b>	<b>8</b>
<b>Annex B (informative) Typical example of a seal test report for the dynamic low temperature test .....</b>	<b>10</b>
<b>Annex C (informative) Typical example of a material test report (thermoplastic element).....</b>	<b>12</b>
<b>Annex D (informative) Typical example of a material test report (elastomeric element) .....</b>	<b>13</b>
<b>Bibliography.....</b>	<b>15</b>

## Foreword

ISO (the International Organization for Standardization) is a worldwide federation of national standards bodies (ISO member bodies). The work of preparing International Standards is normally carried out through ISO technical committees. Each member body interested in a subject for which a technical committee has been established has the right to be represented on that committee. International organizations, governmental and non-governmental, in liaison with ISO, also take part in the work. ISO collaborates closely with the International Electrotechnical Commission (IEC) on all matters of electrotechnical standardization.

International Standards are drafted in accordance with the rules given in the ISO/IEC Directives, Part 2.

The main task of technical committees is to prepare International Standards. Draft International Standards adopted by the technical committees are circulated to the member bodies for voting. Publication as an International Standard requires approval by at least 75 % of the member bodies casting a vote.

Attention is drawn to the possibility that some of the elements of this document may be the subject of patent rights. ISO shall not be held responsible for identifying any or all such patent rights.

ISO 16589-4 was prepared by Technical Committee ISO/TC 131, *Fluid power systems*, Subcommittee SC 7, *Sealing devices*.

This second edition cancels and replaces the first edition (ISO 16589-4:2001), which has been technically revised.

iTeh STANDARD PREVIEW  
(standards.iteh.ai)

ISO 16589 consists of the following parts, under the general title *Rotary shaft lip-type seals incorporating thermoplastic sealing elements*:

<https://standards.iteh.ai/catalog/standards/sist/a0945f75-cd42-4a2e-a24b-188a03cf09b0/iso-16589-4-2011>

- *Part 1: Nominal dimensions and tolerances*
- *Part 2: Vocabulary*
- *Part 3: Storage, handling and installation*
- *Part 4: Performance test procedures*
- *Part 5: Identification of visual imperfections*

## Introduction

Rotary shaft lip-type seals are used to retain fluid in equipment where the differential pressure is relatively low. Typically, the shaft rotates and the housing is stationary, although in some applications the shaft is stationary and the housing rotates.

Dynamic sealing is normally the result of a designed interference fit between the shaft and a flexible element incorporated in the seal.

Similarly, a designed interference fit between the outside diameter of the seal and the diameter of the housing bore retains the seal and prevents static leakage.

Careful storage and handling and proper installation of all seals are necessary to avoid hazards, both prior to and during installation, which would adversely affect service life.

## iTeh STANDARD PREVIEW (standards.iteh.ai)

[ISO 16589-4:2011](https://standards.iteh.ai/catalog/standards/sist/a0945f75-cd42-4a2e-a24b-188a03cf09b0/iso-16589-4-2011)

<https://standards.iteh.ai/catalog/standards/sist/a0945f75-cd42-4a2e-a24b-188a03cf09b0/iso-16589-4-2011>

**iTeh STANDARD PREVIEW**  
**(standards.iteh.ai)**

[ISO 16589-4:2011](https://standards.iteh.ai/catalog/standards/sist/a0945f75-cd42-4a2e-a24b-188a03cf09b0/iso-16589-4-2011)

<https://standards.iteh.ai/catalog/standards/sist/a0945f75-cd42-4a2e-a24b-188a03cf09b0/iso-16589-4-2011>

# Rotary shaft lip-type seals incorporating thermoplastic sealing elements —

## Part 4: Performance test procedures

**WARNING** — Persons using this part of ISO 16589 should be familiar with normal laboratory practice. Whilst this part of ISO 16589 does not purport to address all the safety problems, if any, associated with its application, attention is drawn to the need to employ sensible precautions while handling hot and cold fluids and equipment. It is the responsibility of the user of this part of ISO 16589 to establish appropriate safety and health practices and to ensure compliance with any national regulatory conditions.

### 1 Scope

ISO 16589 specifies seals utilizing sealing elements manufactured from suitably formulated compounds based on thermoplastic materials, such as polytetrafluoroethylene (PTFE). They are considered suitable for use under low pressure conditions.

This part of ISO 16589 specifies general performance tests which can be used for seal qualification purposes. Materials quality control, dynamic testing and supplementary low temperature testing requirements are covered.

NOTE ISO 16589 is complementary to ISO 6194, which covers seals incorporating elastomeric sealing elements.

### 2 Normative references

The following referenced documents are indispensable for the application of this document. For dated references, only the edition cited applies. For undated references, the latest edition of the referenced document (including any amendments) applies.

ISO 5598, *Fluid power systems and components — Vocabulary*

ISO 16589-1, *Rotary shaft lip-type seals incorporating thermoplastic sealing elements — Part 1: Nominal dimensions and tolerances*

ISO 16589-2, *Rotary shaft lip-type seals incorporating thermoplastic sealing elements — Part 2: Vocabulary*

### 3 Terms and definitions

For the purposes of this document, the terms and definitions given in ISO 5598 and ISO 16589-2 and the following apply.

**3.1 batch**  
identifiable and traceable consignment of thermoplastic and rubber compounds of definite composition and manufactured in a single production operation

### 4 Pre-test procedure

**4.1** Inspect all seals submitted for testing, for conformity to a relevant drawing or detailed specification, declared by the seal manufacturer.

**4.2** Ensure that the seal manufacturer has stated the material batch numbers from which the seals have been manufactured. For seals with an elastomeric component, ensure that the seal manufacturer has stated the material batch number from which the elastomeric component of the seal has been made.

**4.3** To facilitate accurate analysis of the test results, determine the following data concerning the physical characteristics of the seal and test apparatus before testing:

- a) lip diameter immediately prior to assembly onto the shaft;
- b) lip thickness when measured as assembled on the test shaft;
- c) outer case mean diameter and out of roundness;
- d) shaft diameter, material, hardness and surface roughness;
- e) housing diameter, material and surface roughness;
- f) protection lip diameter, when applicable.

For a), b) and f), measuring instruments with sharp edges should not be used.

The radial lip load should not be measured before the test.

**4.4** Ensure that the specified shaft eccentricity and housing offset of the test apparatus have been incorporated.

### 5 Dynamic normal temperature test

#### 5.1 Test apparatus

The test apparatus shall be similar to the typical example shown in Figure 1 and shall consist of a suitable housing for retaining the test fluid and for positioning the test seals, as well as a rotating member having a spindle mounted horizontally on suitable bearings. The design of the housing for the seal shall be in accordance with the dimensions specified in ISO 16589-1. The housing and the rotating member shall be capable of reproducing the eccentricity and offset referred to in 4.4.



The test apparatus shall also conform to the following additional requirements.

- a) The shaft shall be capable of cycling and/or maintaining the shaft speeds to within  $\pm 5$  %.
- b) The shaft shall be capable of maintaining the specified test eccentricity under dynamic conditions to within  $\pm 0,03$  mm throughout each test.
- c) The test head shall be designed and constructed so as to maintain the housing bore alignment relative to the test shaft axis within  $\pm 0,03$  mm throughout the operating temperature range.
- d) The design of the test head support shall ensure minimum deformation and vibration.
- e) The test head and heat transfer system shall be capable of maintaining the temperature of the test fluid within  $\pm 5$  °C and shall be vented to atmosphere.
- f) Heat shall be applied in a manner that does not subject the test fluid to high localized temperatures which could cause fluid decomposition.
- g) The test shaft shall have a surface which is free of helical machine marks and shall comply with the requirements for shafts specified in ISO 16589-1, Clause 7.
- h) The test housing bore shall comply with the requirements specified in ISO 16589-1, Clause 8.
- i) The material properties — including hardness, surface finish and dimensions of the test shaft and test housing bore — shall conform as closely as possible to the shaft and housing bore to be used in service.
- j) A minimum quantity of  $750 \text{ cm}^3$  of test fluid shall be used.
- k) The level of the test fluid in the test head shall be  $0,3 D_1$  to  $0,5 D_1$  above the lowest point of the shaft diameter  $D_1$ .  
<https://standards.iteh.ai/catalog/standards/sist/a0945f75-cd42-4a2e-a24b-188a03cf09b0/iso-16589-4-2011>
- l) Where the seal housings have inboard bearings, the test housing shall be suitably relieved at the bearing supports to prevent excessive fluid pressure between the bearing and seals.
- m) Means shall be provided for collecting and measuring the mass of any fluid leakage from the seals during the test.
- n) The test head shall have a device capable of pressurizing the seal housing to the working pressure.
- o) A liquid level measuring device shall be provided on the test head.

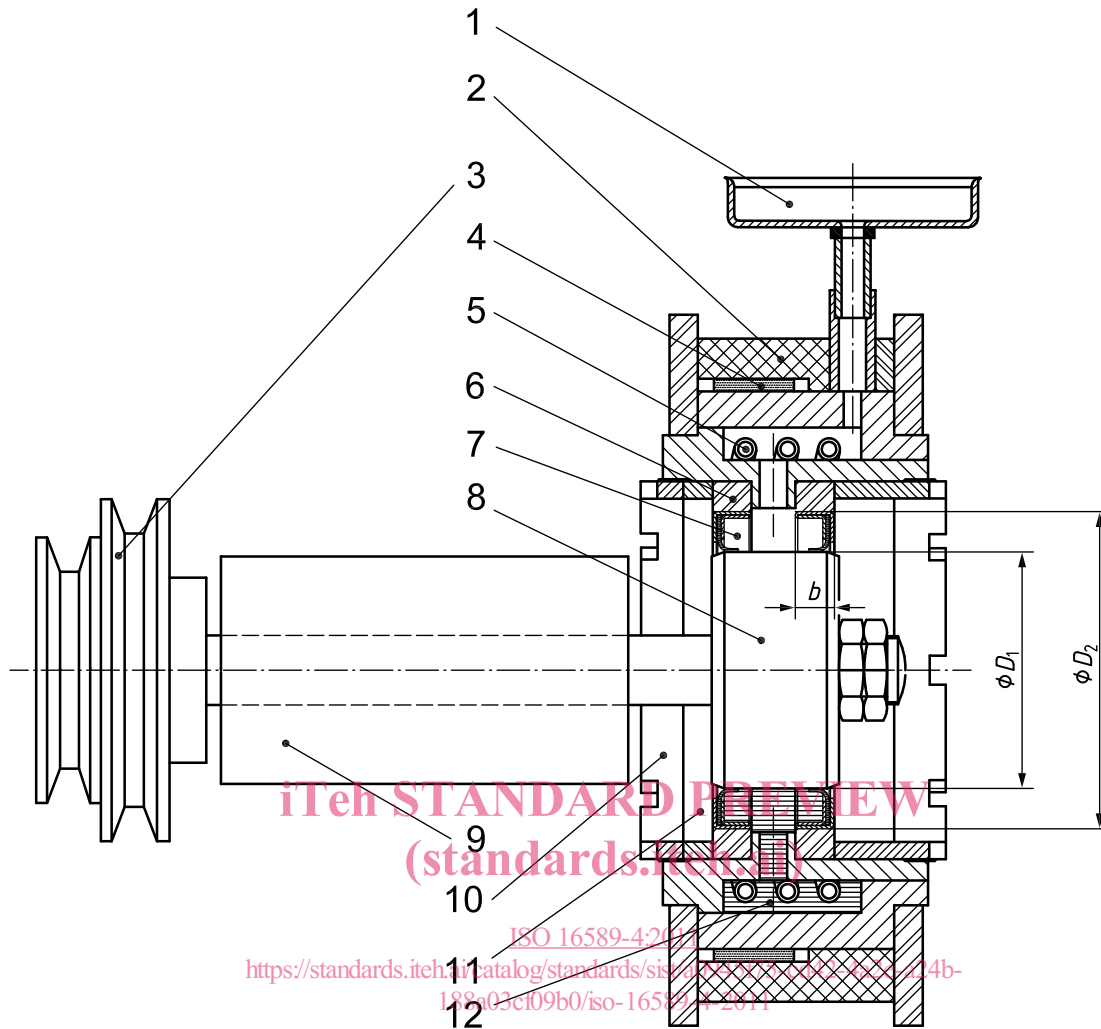

**Key**

- |   |                        |    |                   |
|---|------------------------|----|-------------------|
| 1 | filler tray            | 7  | test seal         |
| 2 | insulation             | 8  | test shaft        |
| 3 | drive from prime mover | 9  | test head support |
| 4 | heater band            | 10 | locking ring      |
| 5 | cooling coil           | 11 | spacer ring       |
| 6 | seal housing           | 12 | test fluid        |

*b* nominal seal width

$D_1$  nominal diameter of the shaft to be used with the seal

$D_2$  nominal diameter of the housing bore or seal outside diameter

**Figure 1 — Typical example of dynamic normal temperature test apparatus**

**5.2 Installation**

**5.2.1** Thoroughly clean the test head of contaminants and extraneous matter.

**5.2.2** Install the seals into the test head so that the cumulative eccentricities of the seals and the test head are known.

**5.2.3** Ensure that the plane of the seal lip is perpendicular to the shaft axis, unless otherwise specified.

**5.2.4** Locate the test shaft in such a position that a clean unused area of its surface is in contact with the sealing element of the test seal.

**5.2.5** Introduce the test fluid, which should be identical to the service fluid, through the filler tray as shown in Figure 1.

**5.2.6** If the viscosity of the test fluid is too high to flow out of the filler tray of its own accord, remove the filler tray shown in Figure 1 and replace with an adapter incorporating a grease nipple. Pump the requisite volume of test fluid through the nipple using a grease gun. Remove the grease nipple prior to the start up, thus preventing over pressurization of the seals. Replace filler tray.

### 5.3 Test conditions

Apply test conditions which simulate the seal application operating conditions, as agreed between the purchaser and supplier, i.e. normal operating temperature, normal operating shaft speed, maximum envisaged operating temperature, and maximum envisaged shaft speed.

### 5.4 Test procedure

Submit six seals to ten cycles, each of 24 h duration, consisting of 14 h at normal operating temperature and speed, according to service conditions, and 6 h at the maximum envisaged operating temperature and speed, followed by a 4 h shut-down to allow the test machine to cool to room temperature. If applicable, each alternate cycle shall be in the reverse direction of rotation.

### 5.5 Post-test measurements

After completion of the test, determine the seal thickness profile, i.e. when measured on a mandrel and where applicable, the protection lip diameter.

### 5.6 Recording

Record all the test data on a seal test report.

NOTE An example of a seal test report for the dynamic test is shown in Annex A.

### 5.7 Acceptance criteria

Typically, the leakage from all six seals shall not be greater than 12 cm<sup>3</sup> and the leakage from any single seal shall be not greater than 3 cm<sup>3</sup>.

Since leakage is dependent on the application and on the design of the seal, the allowable leakage should be agreed between the purchaser and manufacturer.

## 6 Dynamic low temperature test

### 6.1 General

This test is applicable to all rotary shaft lip-type seals for which the minimum specified operating temperature is stated to be –10 °C or lower.

### 6.2 Test apparatus

The test apparatus shall be similar to the typical example shown in Figure 2.

The test shaft and seal housing shall simulate the envisaged maximum eccentricities specified by the customer. The test shaft diameter, the test shaft surface roughness and seal housing dimensions shall also be those specified by the customer or as specified in ISO 16589-1.